

# User's manual



9357168  
ISSUE 2 EN

Nokia is a registered trademark of Nokia Corporation, Finland.

Copyright. © 1995-1998 Nokia Mobile Phones. All rights reserved.

Nokia Mobile Phones operates a policy of continuous improvement. Therefore, we reserve the right to make changes and improvements to any of the products described in this guide without prior notice.

Nokia Mobile Phones is not responsible for any loss of data, income or any consequential damage howsoever caused. Geoworks® application software and GEOS® operating system software copyright © 1990-1998 Geoworks. All rights reserved. United States Patent 5,327,529.

Hardware and software floating point math library copyright © 1984-1991 Dimensions Research, Inc.

This product includes software developed by the University of California, Berkeley and its contributors. Copyright 1979, 1980, 1983, 1986, 1988, 1989, 1991, 1992, 1993, 1994 The Regents of the University of California. All rights reserved. The software is provided by The Regents and contributors "as is" and any express or implied warranties, including, but not limited to, the implied warranties of merchantability and fitness for a particular purpose are disclaimed. In no event shall The Regents or contributors be liable for any direct, indirect, incidental, special, exemplary, or consequential damages (including, but not limited to, procurement of substitute goods or services; loss of use, data, or profits; or business interruption) however caused and on any theory of liability, whether in contract, strict liability, or tort (including negligence or otherwise) arising in any way out of the use of this software, even if advised of the possibility of such damage.

The GEOS® software of this product includes Nimbus Q from Digital Typeface Corp. and typefaces from URW, GmbH. This device contains Embedded DOS-ROM (R), Embedded BIOS (R) software licensed from General Software, Inc. Copyright © 1998 General Software, Inc. General Software, Embedded DOS, and Embedded BIOS are trademarks or registered trademarks of General Software, Inc.

Portions of this work are derived from the Standard C Library, © 1992 by P.J. Plauger, published by Prentice-Hall, and are used with permission.

HP Database Engine Version 1.0 copyright © Hewlett-Packard Company 1994. All rights reserved.

The PPP software is copyright © 1991, 1992, 1993, 1994 Morning Star Technologies, all rights reserved. It contains software developed at Carnegie Mellon University, which is copyright © 1989 Carnegie Mellon University, all rights reserved. It contains software developed at the University of California, Berkeley, which is copyright © 1989 Regents of the University of California, all rights reserved. It contains software that is copyright © 1990, RSA Data Security, Inc., all rights reserved.

C-client Internet mail routines original version copyright 1988 by the Leland Stanford Junior University, copyright 1995 by the University of Washington. The University of Washington and the Leland Stanford Junior University disclaim all warranties, express or implied, with regard to this software, including without limitation all implied warranties of merchantability and fitness for a particular purpose, and in no event shall the University of Washington or the Leland Stanford Junior University be liable for any special, indirect or consequential damages or any damages whatsoever resulting from loss of use, data or profits, whether in an action of contract, tort (including negligence) or strict liability, arising out of or in connection with the use or performance of this software.

This product includes software based in part on the work of the independent JPEG group.

CellularWare is a trademark of Nokia Mobile Phones.

AT is a trademark of Hayes Microcomputer Products, Inc.

Hayes is a registered trademark of Hayes Microcomputer Products, Inc.

Microsoft and MS-DOS are registered trademarks and Windows is a trademark of Microsoft corporation.

Geoworks® and GEOS® are Registered Trademarks of Geoworks, and GeoDOS is a Trademark of Geoworks in the United States of America and other countries.

Intellisync is a trademark of Puma Technology, Inc.

All other brand and product names are trademarks or registered trademarks of their respective holders.

This product contains the RSA Software.



The products described in this manual conform to the European Council directives EMC Directive (89/336/EEC) and TTE Directive (91/263/EEC).

## END USER LICENSE AGREEMENT FOR SECURITY SOCKETS LAYER - SOFTWARE ("SSL")

READ THE FOLLOWING TERMS AND CONDITIONS CAREFULLY BEFORE USING THE SSL. USE OF THE SSL SOFTWARE INDICATES YOUR ACCEPTANCE OF THESE TERMS AND CONDITIONS.

In this license agreement ("License Agreement"), you, the purchaser of the license rights granted by this Agreement, are referred to as "Licensee." In accordance with the terms and conditions of this License Agreement, Nokia Mobile Phones Ltd. ("Licensor") grants Licensee a non-exclusive sublicense to use SSL Software ("Software"), which contains the RSA Software licensed to Licensor by RSA Data Security, Inc. ("RSA").

This License Agreement is effective until terminated. Licensor may terminate this License Agreement if Licensee breaches any of the terms and conditions. In the event of termination by Licensor, Licensee will return the communicator device of Licensor to Licensee for removal of the Software. All provisions of this Agreement relating to disclaimers of warranties, limitation of liability, remedies, or damages, and Licensor's proprietary rights shall survive termination.

The Software is delivered in object code only.

Licensor shall utilize the Software solely as part of the communicator device from Licensor and solely for personal or internal use and without right to license, assign or otherwise transfer such Software to any other person or entity. Licensee shall not modify, translate, reverse engineer, decompile or disassemble the Software or any part thereof.

Licensee agrees not to remove or destroy any proprietary, trademark or copyright markings or notices placed upon or contained within the Software or any related materials or documentation.

By reason of this Agreement or the performance hereof, Licensee shall acquire no rights of any kind in any trademark, trade name, logo or product designation under which the Software was or is marketed and Licensee shall not make any use of the same for any reason.

IN NO EVENT WILL LICENSOR OR RSA BE LIABLE TO LICENSEE FOR INDIRECT, INCIDENTAL, SPECIAL, CONSEQUENTIAL OR EXEMPLARY DAMAGES ARISING OUT OF OR RELATED TO THIS AGREEMENT, INCLUDING BUT NOT LIMITED TO LOST PROFITS, BUSINESS INTERRUPTION OR LOSS OF BUSINESS INFORMATION, EVEN IF SUCH PARTY HAS BEEN ADVISED OF THE POSSIBILITY OF SUCH DAMAGES AND REGARDLESS OF WHETHER ANY ACTION OR CLAIM IS BASED ON WARRANTY, CONTRACT, TORT OR OTHERWISE. UNDER NO CIRCUMSTANCES SHALL LICENSOR'S OR RSA'S TOTAL LIABILITY ARISING OUT OF OR RELATED TO THIS AGREEMENT EXCEED THE TOTAL AMOUNT PAID BY LICENSEE.

THIS AGREEMENT IS EXPRESSLY MADE SUBJECT TO ANY LAWS, REGULATIONS, ORDERS OR OTHER RESTRICTIONS ON THE EXPORT FROM THE UNITED STATES OF AMERICA OF THE SOFTWARE OR OF INFORMATION ABOUT THE SOFTWARE WHICH MAY BE IMPOSED FROM TIME TO TIME BY THE GOVERNMENT OF THE UNITED STATES OF AMERICA. NOTWITHSTANDING ANYTHING CONTAINED IN THIS AGREEMENT TO THE CONTRARY, LICENSEE SHALL NOT EXPORT OR REEXPORT, DIRECTLY OR INDIRECTLY, ANY SOFTWARE OR INFORMATION PERTAINING THERETO TO ANY COUNTRY TO WHICH SUCH EXPORT OR REEXPORT IS RESTRICTED OR PROHIBITED, OR AS TO WHICH SUCH GOVERNMENT OR ANY AGENCY THEREOF REQUIRES AN EXPORT LICENSE OR OTHER GOVERNMENTAL APPROVAL AT THE TIME OF EXPORT OR REEXPORT WITHOUT FIRST OBTAINING SUCH LICENSE OR APPROVAL.





**FOR YOUR SAFETY** Read these simple guidelines. Breaking the rules may be dangerous or illegal. Further detailed information is given in this manual.



**ROAD SAFETY COMES FIRST** Do not use the communicator while driving; park the vehicle first.



**INTERFERENCE** All wireless phones may get interference which could affect performance.



**SWITCH OFF IN HOSPITALS** Follow any regulations or rules. Switch off the phone near medical equipment.



**SWITCH OFF IN AIRCRAFT** Wireless phones can cause interference. Using them on aircraft is illegal.



**SWITCH OFF WHEN REFUELLING** Do not use the phone at a refuelling point. Do not use near fuel or chemicals.



**SWITCH OFF NEAR BLASTING** Do not use the phone where blasting is in progress. Observe restrictions, and follow any regulations or rules.



**USE SENSIBLY** Use only in the normal position (to ear). Do not touch the antenna unnecessarily.



**USE QUALIFIED SERVICE** Only qualified service personnel must install or repair equipment.





**ACCESSORIES AND BATTERIES** Use only approved accessories and batteries. Do not connect incompatible products.



**MAKING CALLS VIA THE PHONE** Close the cover and ensure the phone is switched on and in service. Enter the phone number, including the area code, then press . To end a call press . To answer a call press .



**EMERGENCY CALLS** Close the device cover. Ensure the phone is switched on and in service. Hold  for several seconds, to clear the display. Enter the emergency number, then press . Give your location. Do not end the call until told to do so.



**MAKE BACKUP COPIES** Remember to make backup copies of all important data.



**CONNECTING TO OTHER DEVICES** When connecting to any other device, read its user's guide for detailed safety instructions. Do not connect incompatible products.



**INFRARED PRECAUTIONS** Do not point the IR beam at anyone's eye or allow it to interfere with other IR devices.

# Table of contents

<b>Table of contents</b>	<b>6</b>
<b>Introduction</b>	<b>11</b>
About this manual	12
Facts about your communicator	13
Facts about cellular data transmission	14
<b>Getting started</b>	<b>17</b>
First start-up	17
Communicator display	20
Communicator keyboard	24
Communicator applications	25
Connectors	26
Battery	27
<b>Special features</b>	<b>31</b>
Communicator features	31
Document features	34
To transfer data from older communicator models	37
<b>PC connectivity</b>	<b>39</b>
To use the PC Suite	39
To use the Nokia Communicator Server	46
<b>Contacts</b>	<b>49</b>
Contacts directory	49
To make contact cards	51
Contact groups	54
Logs	55
<b>Telephone</b>	<b>57</b>
To make a call	57
To answer a call	58

Handsfree mode	59
Multiple calls	60
Telephone settings	63
Flight profile	67
<b>Fax</b>	<b>69</b>
To send faxes	69
To receive faxes	71
Fax settings	72
<b>Short messages</b>	<b>75</b>
To send short messages	76
To receive messages	77
Standard messages	78
Business cards	79
SMS settings	80
<b>Internet</b>	<b>83</b>
Internet settings	84
Mail	87
Mail settings	87
To send mail	90
To fetch mail	92
To read mail	93
World Wide Web	95
WWW settings	95
Bookmarks	96
To navigate in WWW	99
Terminal	102
Telnet	105
Text Web	107
<b>Notes</b>	<b>109</b>
To edit documents	111
Downloaded files and read-only documents	112
Notes settings	113

<b>Calendar</b>	<b>115</b>
Monthly schedule	115
Weekly schedule	116
Daily schedule	117
Calendar booking	119
Alarms	121
To-do list	121
<b>System</b>	<b>123</b>
System settings	123
Security	125
User data	128
Memory	128
Infrared activation	129
Digital camera connectivity	129
Remote synchronisation	130
Fax modem	131
Data removal	132
Install/Remove software	132
Backup/Restore	133
Memory card tool	133
About this product	133
<b>Extras</b>	<b>135</b>
Calculator	135
Clock	136
Composer	139
Voice recorder	142
<b>Phone</b>	<b>145</b>
Display indicators	146
To make a call	147
To answer a call	148
To manage calls	148
To search for phone numbers	149
To use speed dialling	149
To send DTMF tones	150



Keypad lock	150
Help	151
To use the menus	151
Messages (Menu 1)	153
Call register (Menu 2)	154
Profiles (Menu 3)	156
Settings (Menu 4)	157
Call divert (Menu 5)	161
Recorder (Menu 6)	162
<b>Troubleshooting</b>	<b>163</b>
<b>Care and maintenance</b>	<b>169</b>
<b>Important safety information</b>	<b>171</b>
<b>Glossary</b>	<b>175</b>
<b>Index</b>	<b>179</b>



# 1. Introduction

Congratulations on purchasing the Nokia 9110 Communicator. The Nokia 9110 Communicator is a complete communications tool: it is a wireless phone, messaging device, access terminal and a palmtop organiser in one pocketable package.

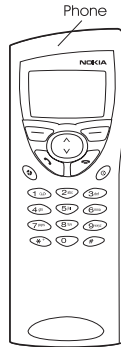

Figure 1

The Nokia 9110 Communicator consists of two parts: the phone and the communicator interface. The phone is on the device cover (figure 1) and the communicator interface is under the cover (figure 2).

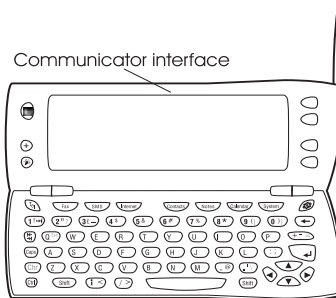

Figure 2

Both of these parts use the same resources and work closely together – they are not separate devices. For example, the phone uses the names and phone numbers stored in the Contacts directory of the communicator interface, and the communicator interface uses the phone for communicating with the "outside world", for example, when sending or receiving faxes and connecting to the Internet.

The communicator interface contains many organiser and communications applications. The large keyboard, command buttons and display make using the applications easy. The communicator interface has no power on/off button – it switches itself on when you open the cover and switches off when you close the cover.

**Tip:** Press the **i** button on the communicator interface keyboard to find basic information about the communicator applications.

The phone is designed for making and answering calls quickly. It looks and operates like other Nokia wireless phones, except that the earpiece and microphone are on the rear of the device. The phone is switched on and off by pressing the **⓪** button on the cover.

**IMPORTANT!** Do not switch on the phone when wireless phone use is prohibited or when it may cause interference or danger.

## About this manual

This chapter explains how the Nokia 9110 Communicator operates. The following chapter, "Getting started", helps you begin using the Nokia 9110 Communicator. It explains the start-up procedure and gives information about the various aspects of the device, such as the keyboard and the display. "Special features" explains special functions, and "PC connectivity" shows how to connect your communicator to a PC.

The rest of this manual deals with the communicator applications and the phone. There is a short glossary of Internet and cellular terms and abbreviations at the back of this manual.

If you are switching from the Nokia 9000 Communicator or the Nokia 9000i Communicator to the Nokia 9110 Communicator, please, see "To transfer data from older communicator models" on page 37.

**Note:** In this manual, the names of the commands on the display are in **bold** and the settings and options are in *italics*.

## Facts about your communicator

### Services

The GSM system provides a number of various wireless services, but they are not automatically enabled to the wireless phone user. Even though the Nokia 9110 Communicator represents the latest development in wireless phone technology, using its various communications applications requires that you have subscribed to these services and that your network operator has activated these services for you. Services that need to be subscribed to are typically the short message service, Internet and fax.

Because the number of special services depends on what services are available in your home network, it is, unfortunately, impossible to provide a comprehensive list of the services and settings you need in this manual. Therefore, this manual gives general information about the additional services. Please, contact your network operator for further information about the availability and the details of services in your home network.

If a service requires a separate phone number or specific settings, they must be stored in the settings of the communicator. For example:

Sending and receiving short messages requires that this service is supported by the network you are using and activated for your SIM card, and that the phone number of the message centre is stored in the settings of the SMS application.

Internet access requires that data service is supported by the network you are using and activated for your SIM card. In addition, you must have obtained an Internet access point from an Internet service provider.

### Access codes

The Nokia 9110 Communicator uses several access codes to protect against unauthorised use of your communicator and SIM card. The access codes you need most often are the lock code, which is provided in the sales package, and the PIN code, which is provided with the SIM card.

You can change access codes that are used by both the phone and the communicator interface via either of them, provided that the code can be changed. For more details on the access codes, see "Security" on page 125.

The Internet applications of the communicator use passwords and user names to protect from unauthorised use of the Internet and its services. These passwords are changed in the settings of the Internet applications.

## Contact information

All contact information, such as names, addresses, phone numbers, that you store, goes into the Contacts directory. The phone, the communicator interface, and each of the applications have their own views of the Contacts directory. The information shown depends on the information the selected application can use. For example, when you are making a call via the phone, you can view the name and the phone number(s) of the contact. Possible fax numbers, e-mail addresses, job titles, etc., are not shown.

## Facts about cellular data transmission

The Nokia 9110 Communicator employs the data transmission capabilities of the GSM network to send faxes, short messages and e-mail, and to establish connections with remote computers.

Cellular data connections can be made from most locations where your wireless phone operates. However, it is recommended that you move the communicator to a location where the strongest possible cellular signal can be obtained. When the signal is strong, data transmission is efficient. In general, you should not expect the same performance from cellular data communications as from landline communications due to the inherent characteristics of the cellular environment. The following factors may impair cellular connections:

### Noise

Radio interference from electronic appliances and equipment, as well as from other wireless phones in metropolitan areas where wireless phones are prevalent.

### Handover

As the wireless phone user moves from one network cell to another, the signal strength of the channel drops and the cellular telephone exchange may hand the user over to a different cell and frequency, where the signal is stronger. A cell handover may also occur when the user is stationary due to varying cellular traffic loads. Such handovers may cause slight delays.

### Electrostatic discharge

A discharge of static electricity from a finger or a conductor may cause erroneous functions in electric devices. The discharge may result in "garbled" display and unstable software operation. Cellular connections may become unreliable, data may be corrupted, and the transmission halted. In this case you need to end the existing call (if any), switch off the phone (if on) and remove the battery. Then replace the battery and establish a new cellular connection.

## Dead spots and dropouts

Dead spots are areas where radio signals cannot be received. Dropouts occur when the wireless phone user passes through an area where the radio signal is blocked or reduced by geographic or structural obstructions.

## Signal impairment

Distance and obstacles can cause out-of-phase reflected signals that result in a loss of signal strength.

## Low signal strength

Due to either distance or obstacles, the radio signal strength from a cell site may not be strong or stable enough to provide a reliable cellular connection for communication. Therefore, to ensure the best possible communication, remember to consider the following points:

The data connection works best when the communicator is in a stationary position. Attempting cellular communication while in a moving vehicle is not recommended. Fax transmission is more easily impaired than data or short message transmission.

Do not place the communicator on a metal surface.

Check that the cellular signal strength on the communicator displays is sufficient. See "Communicator display" on page 20 and "To make a call" on page 147. Moving the communicator within a room especially towards a window, may result in a stronger signal. If the cellular signals are not strong enough to support a voice call, data connection should not be attempted until you can find a location with better signal reception.

**Note:** When the antenna is up, the signal is stronger.





# 2. Getting started

This chapter explains how to start up your communicator and install a SIM card, how the communicator operates, and how to supply power to the communicator.

When you open the sales package, check that it contains the following:

- Nokia 9110 Communicator
- This User's manual, the combined Quick guide and Accessories guide, and the Solution guide
- High Power Battery
- AC charger
- RS-232 Adapter Cable
- Diskette package
- CD-ROM with PC connectivity software
- Stickers with the serial number and the lock code of the communicator

For information about the Nokia 9110 Communicator accessories, see the Accessories guide.

## First start-up

- 1 Close the device cover and make sure that the phone is switched off. If it is on, press .

A valid miniature SIM card is required for sending and receiving calls and messages. The card is supplied by your network operator or service provider. If you do not have a SIM card yet, go to step 6.

**Note:** Keep all miniature SIM cards out of small children's reach.

- 2 If the battery is connected to the communicator, remove the battery: press the catch at the top of the battery and lift the battery away from the battery cavity. See figure 1.

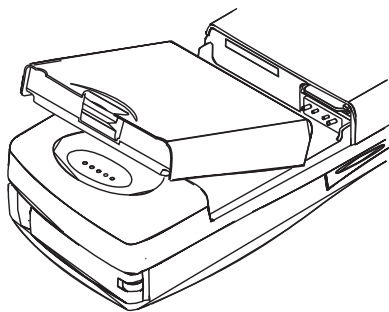

Figure 1

- 3 Slide the SIM card into the SIM card slot: make sure that the gold contacts of the SIM card are facing down and that the bevelled corner of the card is on the right. See figure 2.

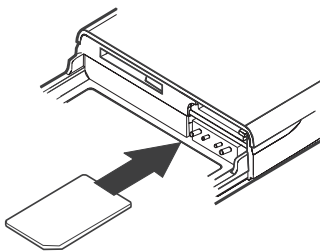

Figure 2

- 4 When the SIM card is properly inserted into the SIM card slot, the bevelled corner will remain visible. See figure 3.

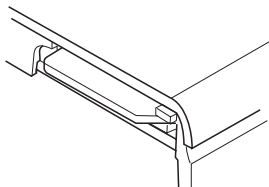

Figure 3

**Note:** If an unacceptable SIM card is inserted, the message INVALID SIM CARD will be displayed. Should this happen, contact your dealer or network operator.

- When you are sure that the SIM card is correctly installed, replace the battery.

**Note:** The battery does not fit into place if the SIM card is not correctly installed. Do not force the battery into place! Check that you have inserted the SIM card into the slot as described above. If the SIM card is incorrectly installed, remove it by pulling it away from the slot, and insert it again.

- If there is little or no charge in the battery, it is recommended that you connect the communicator to the charger and start charging the battery before continuing with the start-up procedure. See "Battery" on page 27.
- Open the cover of the communicator. You will see a welcome screen while the communicator performs a self-test.
- After the self-test is complete, you will see a list of countries on the display, see figure 4. Scroll the dark grey selection frame using the arrow keys on the keyboard over the name of your home country. Press the button on the right side of the display next to the command **OK**. The capital of your home country will be set as your home city. You can change your home city later in the Clock application, see "Clock" on page 136.

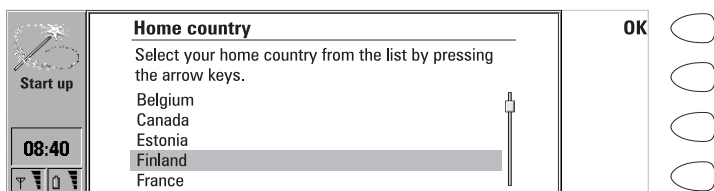

Figure 4

- Write the current date in the input field using the format *dd.mm.yy*, for example 22.03.98. Press **OK**. You can later change the date format in the System settings. Time and date can be changed in the settings of the Clock application.

10 Write the current time using the 24-hour format *hh:mm*, for example 17:25, and press **OK**. You can later change the time format in the System settings.

11 Enter your contact information in the user data card and press **OK**. You can later change the information in the User data application under System.

The first start-up is now completed.

After the start-up, do not immediately remove the battery, as the battery charges the backup battery that supplies power to the real-time clock of the communicator.

**Note:** When taking the phone into use, observe the instructions given by your network operator.

### To copy the SIM card contents to the Contacts directory

If the installed SIM card contains names or numbers, you will be asked after the start-up procedure if you want to copy the SIM card contents into the memory of your communicator. If the phone is switched off, the question will be asked the next time the phone is on and you open the cover of the communicator.

If you want to do the copying later, press **Cancel**, and do it in the Contacts application, see "Contacts directory" on page 49.

All phone numbers copied from the SIM card to the communicator memory will go to the *Tel* field of the contact cards. Therefore, you must move all wireless phone numbers manually into the *Tel(GSM)* field. See "To make contact cards" on page 51. The quickest way to copy a phone number is to select the number with the key combination Shift-Ctrl-left arrow, cut it with Ctrl-X, and paste it to the right contact card field with Ctrl-V.

## Communicator display

The communicator interface is switched on by opening the cover. See figure 5.

The applications are run in the middle of the display. The indicators (figure 6) show application and system-related information. The commands always correspond to the column of four command buttons on the right side of the display. The functions of the Menu, Zoom and Backlight buttons are explained in "Communicator features" on page 31.

The scroll bar indicates that there are more items than currently shown on the display. The display can be scrolled with the up and down arrow keys.

Whenever the selection frame is shown, you can select items by moving the selection frame over the desired item with the up and down arrow keys.

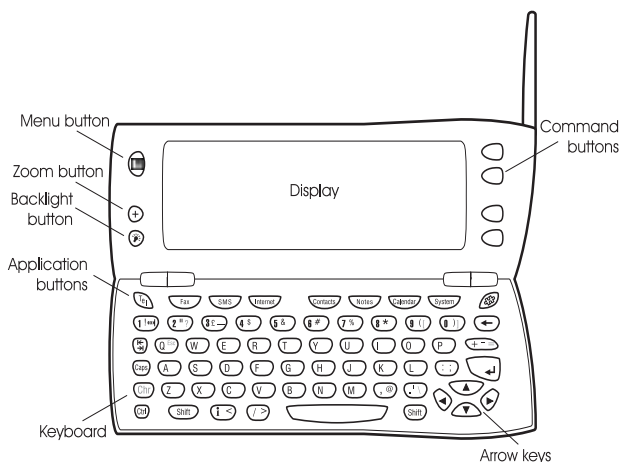

Figure 5

When the search field appears at the bottom of the display, you can search for items by entering text into the search field with the keyboard.

After the correct item has been selected, press the command button next to the command you wish to apply to the item, for example, **Open**.

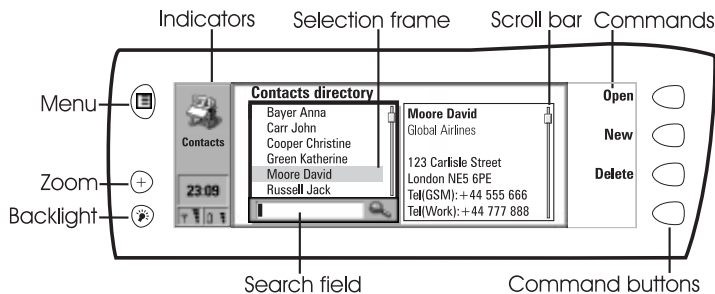

Figure 6

The following figures illustrate certain communicator conventions:

- ① When a command is dimmed, it cannot be used, see figure 7.
- ② When a cursor appears on a dotted line, enter a value with the keyboard, see figure 7.

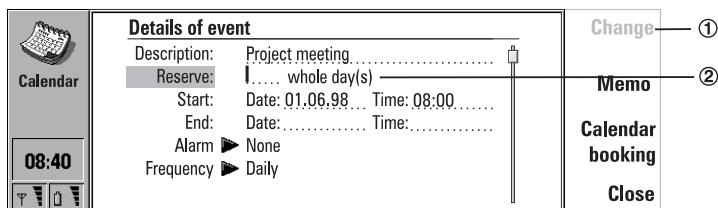

Figure 7

③ A pop-up box. Select an item and press **OK** or **Cancel**, see figure 8.

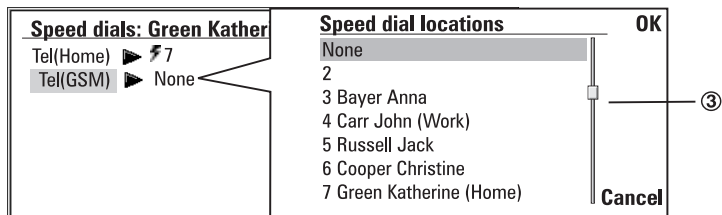

Figure 8

When a setting with ► next to it is selected, pressing **Change** toggles the value or opens a pop-up box. See figure 8. When a setting with [ ] next to it is selected, pressing **Change** opens a new settings view. When you press a command with ► next to it, the commands change.







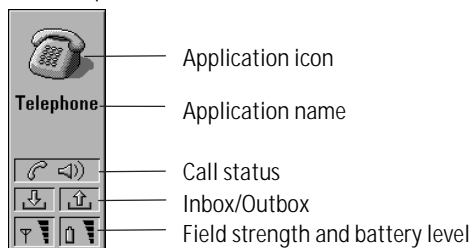



## Indicators

The application icon and the application name in the indicator area show the application you are in at the moment.



The icons that appear on the Call status and Inbox/Outbox indicator rows change according to the application and current situation. The battery level and field strength indicators are the same as shown on the phone display when the phone is on.





## Call status

-  – You have a voice call, and the handsfree loudspeaker and microphone are on. See "Handsfree mode" on page 59.
-  – A voice call with the handsfree off. The loudspeaker and microphone are muted.
-  – An open data connection, see chapter 9 "Internet" on page 83.
-  – The communicator is receiving or sending a fax, see chapter 7 "Fax" on page 69.
-  – The communicator is trying to establish an infrared connection, see chapter 4 "PC connectivity" on page 39.
-  – An infrared connection has been established.
-  – The infrared connection is obstructed.
-  – The communicator is connected to a PC, see chapter 4 "PC connectivity" on page 39.
-  – The communicator is being used as a fax modem, see "Fax modem" on page 131.
-  – The communicator is in a special operating environment, in this case in the meeting profile. See "Telephone settings" on page 63.
-  – Time can be adjusted in the Clock application, see "Clock" on page 136.

## Inbox/Outbox

-  – The inbox indicator informs you that you have received a fax, short message or mail.
-  – The Document outbox contains unsent messages, see "Communicator features" on page 31.

## Battery level

-  – The battery is low and should be recharged.
-  – The battery is charging. The bar scrolls until the battery is fully charged. The outlet plug icon indicates that the communicator is connected to an external power source.
-  – The battery is fully charged. All the four bars are displayed.

## Field strength

-  – The communicator is connected to a cellular network. When all the four bars are shown, the cellular signal reception is good. If the signal is weak, make sure the antenna is up. You can also try



- To improve the reception by moving the communicator slightly or by using it in the handsfree mode.
- The phone is on, but it is outside network coverage.
- The phone is off. The communicator cannot send or receive calls or messages.

## Communicator keyboard

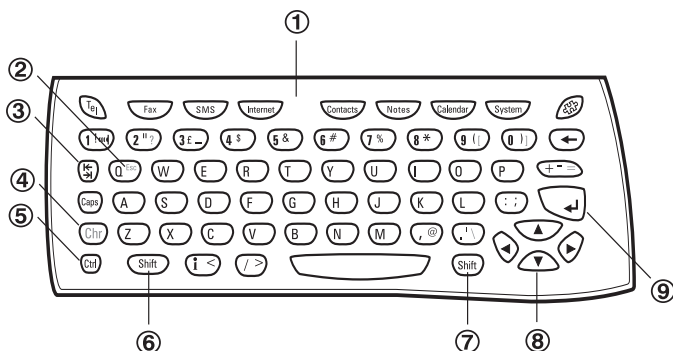

Figure 9

In addition to the normal character and number keys, the keyboard has a number of special keys, as shown in figure 9.

### ① Application buttons

The buttons at the top of the keyboard start the corresponding applications.

### ② ESC

To cancel an action, you can either press **Cancel** or Chr-Q. The Chr-Q key combination can only be used when **Cancel** is among the available commands. All information notes shown on the display can also be dismissed by pressing Chr-Q instead of **OK**.

### ③ Tabulator

When writing or editing documents, the tabulator key moves the cursor to the next tabulator stop. In settings, for example, the tabulator key can be used to move the cursor to the next field.

### ④ Character (Chr)

The character key is used to generate characters not on the communicator keyboard. A single press of the character key opens a table of special



characters. Some special characters are also printed on a key as the third character. These, and certain other characters can be generated by pressing and holding the character key while pressing the corresponding key, see "To edit documents" on page 111.

### ⑤ Control (Ctrl)

Pressed together with certain keyboard keys, the control key generates shortcut commands which can be used in viewing and writing text, see "Document features" on page 34.

### ⑥ and ⑦ Shift

When you press the Shift key and then a letter key, an uppercase letter is inserted in front of the cursor. The Shift key does not need to be held down when pressing a key: once you have pressed Shift, the next key press always generates a shifted character. In writing and editing text, Shift and the arrow keys (⑧) can be used to select text, see "Document features" on page 34.

### ⑧ Arrow keys

The arrow keys can be used to move the cursor or the selection frame. In some applications, the arrow keys have special functions, see "Document features" on page 34.

### ⑨ Enter

When the cursor is shown, pressing Enter moves the cursor to the beginning of the next line or adds a new line. Enter can also be used to select contacts in the Contacts directory and to open folders and documents. When information notes are shown, you may press Enter instead of **OK**. In options and settings, when a value can be toggled, you may press Enter instead of **Change**.

## Communicator applications

The coloured application buttons on the communicator keyboard are used to start the corresponding applications.

**Telephone** — Used for managing voice calls.

**Fax** — Enables you to send any of your own documents as a fax. Received faxes can be read or forwarded.

**SMS** — Enables you to send short messages. Received short messages can be read, replied, or forwarded.

**Internet** — Includes Internet and modem-based applications.

**Contacts** — Used for managing contact information, such as names, numbers and addresses. You can exchange contact information as business cards via the SMS application.

**Notes** — Used for writing and storing documents.

**Calendar** — Contains an appointment book and a to-do list. You can book events in other calendars and set alarms to events.

**System** — Contains PC connectivity, security and other system-related applications.

**Extras** (☰) — Includes various items, such as Calculator, Clock, and Composer.

### To use the applications

When the cover is opened, the application that was on the display when you closed the cover, appears in the same state. However, if you have made or answered a voice call via the phone and switch to the communicator interface by opening the cover, the Telephone application starts automatically.

To switch to another application, press the corresponding application button. You can do this even during a call. You need not exit any application before starting another. All inactive applications remain in the background until you start them again.

To send or receive calls or messages with any of the communications applications, remember that the phone must be switched on and in a service area with adequate cellular signal strength.

**Note:** Information needs not be specifically saved. When you press **Close**, switch to another application, or close the device cover, the Nokia 9110 Communicator saves all data.

## Connectors

The Nokia 9110 can be connected to a variety of devices. The connectors are (figure 10):

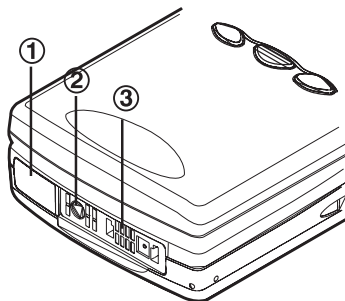

Figure 10

- ① IrDA-SIR infrared port for connecting to a PC, a printer, a digital camera, or another communicator. For information on infrared connection, see chapter 4 "PC connectivity" on page 39.
- ② Connector for the charger plug.
- ③ Connector for the RS-232 cable plug and the headset plug.

## Battery

The Nokia 9110 Communicator is powered by a rechargeable Lithium-ion battery. The High Power Battery provides 3 to 6 hours of talk/fax/terminal time or 60 to 170 hours of standby time. Furthermore, up to 400 hours of standby time may be achieved when the phone is off.

Use only batteries and accessories approved by the communicator manufacturer for use with this particular communicator model. Use only chargers approved by the communicator manufacturer for charging a Lithium-ion battery.

**Note:** The communicator can be used normally during charging.

### To charge a battery

- 1 Make sure that the battery is properly installed in the battery compartment.
- 2 Connect the charger lead to the connector at the bottom of the communicator, as shown in figure 11.

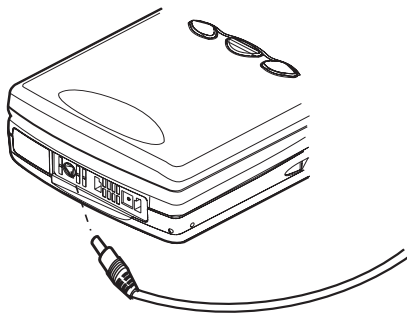

Figure 11

- 3 Connect the charger to an AC wall outlet. If the phone is switched on, the CHARGING message appears on the display and the segments of the battery indicator bar on the right side of the phone display will start scrolling.

- 4 When the battery is fully charged, the bars stop scrolling and four bars are displayed. You may now remove the charger plug from the communicator.

When the charge in the battery is low and only a few minutes of operation time remain, a warning tone will sound, and the message BATTERY IS LOW will be repeated at regular intervals on the phone display. When the charge level becomes too low for operation, the RECHARGE BATTERY message will be displayed, accompanied by a warning tone. If you do not connect the communicator to a charger, the communicator switches itself off.

**Note:** If the battery is fully discharged, it will take 30 - 60 seconds before the CHARGING message appears on the display and the battery indicator bar starts scrolling. After that, it may take 10-30 seconds before you can switch the phone on.

## To use the battery

Use only batteries approved by the communicator manufacturer and recharge the battery only with the chargers approved by the manufacturer. With approved chargers and accessories, the battery can be charged continuously.

The battery need not be fully discharged before recharging. When a charger is not in use, disconnect it from the power source. Do not leave the battery connected to a charger for longer than a week, since excessive charging may shorten its life. If left unused, a fully charged battery will discharge itself over time.

The battery can be charged and discharged hundreds of times, but it will eventually wear out. When the operating time (talk-time and standby time) is noticeably shorter than normal, it is time to buy a new battery.

Temperature extremes will affect the ability of your battery to charge: allow it to cool down or warm up first.

Battery operation time is affected by the following: whether both the phone and the communicator interface are on, radio signal strength, various phone settings, the use of the backlight, and the length of the screen blanker period, see "System settings" on page 123.

It is recommended always to keep a charged battery in the communicator. Keeping the battery charged maximises the lifetime of the backup battery supplying power to the real-time clock of the communicator. In case the backup battery is drained, it will be automatically charged the next time a charged battery is reconnected to the communicator.

Always close the device cover before removing the battery. Closing the cover will save all data.

## Note

Use the battery only for its intended purpose.

Never use any charger or battery which is damaged or worn out.

Do not short-circuit the battery. Accidental short-circuiting can occur when a metallic object (coin, clip or pen) causes direct connection of the + and - terminals of the battery (metal strips at the bottom of the battery), for example, when you carry a spare battery in your pocket or purse. Short-circuiting the terminals may damage the battery or the connecting object.

Leaving the battery in hot or cold places, such as in a closed car in summer or winter conditions, will reduce the capacity and lifetime of the battery. Always try to keep the battery between +15°C (+59°F) and +25°C (+77°F). A communicator with a hot or cold battery may temporarily not work, even when the battery is fully charged. The performance of Lithium-ion batteries is particularly limited in temperatures below 0°C (+32°F).

Do not dispose of batteries in a fire!



Batteries must be recycled or disposed of properly. Batteries must not be disposed of in municipal waste.



# 3. Special features

This chapter explains functions that are common to most of the applications. "Communicator features" on page 31 goes through various features of the device, and "Document features" on page 34 explains functions that apply to writing and viewing of documents.

## Communicator features

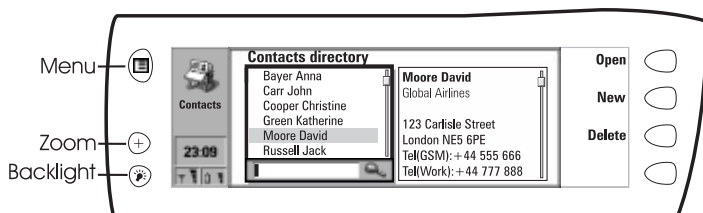



Figure 1

### To use the Menu button

- 1 Press the  button on the left of the communicator display to open up a set of options which depend on the application you are in.
- 2 Move the selection frame over the desired option and press **Select**.

The chosen option affects only the document, card or item that is currently selected, open, or being sent. The Menu may also contain the option *Settings* with which you can change the settings of the application. The values of these settings will be used as defaults for that application.

### To use the Zoom button

Press the  button on the left of the display to magnify the view on the display. Zooming is not available on every occasion.

### To use the Backlight button

Press the  button on the left of the display to turn the backlight of the communicator display on and off. The backlight can be adjusted in the System settings. See "System settings" on page 123.

## To use the Help button

Press the **i** button on the communicator keyboard to open up a help text on the current function. The application icon in the indicator area on the left side of the display reminds you of the application where you requested help.

The help deals with issues relating to the item that was on the display when you pressed the Help button. If no special help is available for the current item, a list of available help topics is shown instead.

To view the list of all help topics for the current application, press **Application help**. The following commands become available:

**Open** — Opens the selected topic.

**General help** — Shows the common help topics.

**Close** — Closes the help.

To view the list of general communicator topics, press **General help**. The following commands become available:

**Open** — Opens the selected topic.

**Application help** — Returns to the help topics list of the current item.

**Close** — Closes the help.

If the help topic you wanted was not among the help topics of the current item or in the general help, close the help, start the correct application and press the Help button again.

## To use the memory card

A memory card may contain documents, contact databases, applications, backups, printer drivers, etc. When a memory card is inserted in the communicator, the memory card contents are marked with the memory card icon  in the corresponding applications. For example, the documents on the memory card are located in a folder shown in the folders list of the Notes application.

The items on the memory card can be used in the same way as corresponding items in the communicator. You can for example install and remove software to and from the memory card with the Install/Remove software application, and send messages to contacts in the contacts directory of the memory card.

**Note:** The memory card is not included in the sales package, but can be purchased separately.

## To insert the memory card

- 1 Close the device cover and make sure that the phone is switched off. If it is on, press **⓪**.
- 2 Remove the battery: press the catch at the top of the battery and lift the battery away from the battery cavity.



- 3 Open the hatch at the back of the communicator: carefully open the lid by easing it up from the ridges on both sides.
- 4 Slide the memory card under the memory card holder. Make sure that the gold contacts of the card are facing down and that the bevelled corner of the card is on the right. See figure 2.

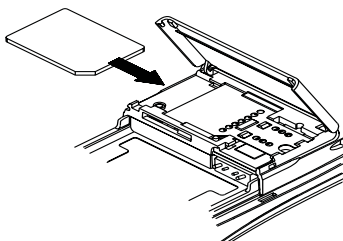

Figure 2

- 5 When the card is securely in place, close the hatch, and replace the battery.

**IMPORTANT!** Keep all memory cards out of small children's reach.

Make sure that the hatch is closed before replacing the battery!

Do not remove the memory card in the middle of an operation. Be sure to close all memory card applications before removing the card.

If you are installing an application to the memory card and you need to reboot the communicator, do not remove the card until the reboot is complete. Otherwise the application files may be lost.

If you have an application or a tone on both the memory card and the communicator, the one in the communicator is used.

### To select several items

Where multiselection is available, you can select several items at once. The commands you use affect all the selected items. Multiselection works in most lists. For example, you can select several contacts and remove them at once in the Contacts directory, or select several documents and copy them to a memory card at the same time in the Notes application.

There are two ways to select several items:

- 1 Scroll to the item and press Ctrl-space bar. Or,
- 2 Press and hold Shift and move up or down the list with the arrow keys to the last selected item.

To remove an item from the selection, scroll to the item and press Ctrl-space bar again.

To cancel the entire selection, press Chr-Q.

If you want to select every item in a list, press Ctrl-A. If you want to cancel the selection, press Ctrl-A again.

## Document features

### To name a document

Every time you close a new document for the first time, you will be asked to enter a name for the document in the input field. The highlighted name in the input field is the communicator's suggestion for the name.

### To use shortcuts

There are several shortcuts you can use in the document applications. The following table lists the available shortcuts:

Shortcut	Function
Ctrl-A Ctrl-C Ctrl-X Ctrl-V Ctrl-Z	Selects all Copies selected text Cuts selected text Pastes selected text Cancels the most recent operation
Ctrl-B Ctrl-I Ctrl-U	Applies bold Applies italics Applies underlining
Ctrl-T Ctrl-D Ctrl-M	Adds current time Adds current date Adds user's name
Ctrl-H Ctrl-E	Moves the cursor to the beginning or the end of the document
Ctrl-N Ctrl-P	Opens the next item Opens the previous item
Chr-left or right arrow	Moves the cursor to the beginning or end of the line
Chr-up or down arrow	Scrolls the list or document view up or down
Shift-Ctrl-left or right arrow	Selects the previous or the next word
Shift-right/left/up/down arrow	While Shift is held down, each press of an arrow key selects one text character or line
Shift-Chr-up or down arrow	Selects text page by page inside a document

## To print

Press the Menu button and select *Print*. You can print various items, such as documents, pictures, and SMS messages.

The connection type, header, paper size and the default printer must be defined in advance in the System settings. See "System settings" on page 123.

**Note:** For information on supported printers, see the Documentation section on the CD-ROM supplied in the communicator sales package, or see the Nokia Wireless Data Forum home page in the World Wide Web at <http://www.forum.nokia.com>.

Please, refer to the user's guide of the printer for detailed safety instructions on the device.

To change the printing options, press **Options** in the printing view. The available options depend on the application you are in.

## To print using the infrared connection

- 1 Go to the System application and set infrared as the connection type. See "System settings" on page 123.
- 2 Make sure the infrared port of the communicator faces the infrared port of the printer. Keep the infrared connection clear. If the connection is obstructed for too long, for example, if something is moved between the infrared sensors or the communicator is moved, printing is interrupted.
- 3 After the communicator has checked that you do not already have an active connection, it starts to scan for a printer. This means that you cannot print while you are, for example, transferring files from the communicator to a PC.
- 4 If the printer cannot be found, a failure note is shown and the active application returns to the display.  
If the correct printer is found, the printer driver is selected automatically and the display shows the name of the document and the selected printer. If the printer found is not recognised, press **Printers** and select the correct printer driver.  
If the communicator does not have the correct driver for the printer, you can try printing the document using one of the available printer drivers.
- 5 Press **Start** to start printing.

**Tip:** More printer drivers can be installed with the PC Suite for Nokia 9110 Communicator program or from the CD-ROM included in the communicator sales package. See "To use the PC Suite" on page 39.

## To print using the cable connection

- 1 Go to the System application and set cable as the connection type. See "System settings" on page 123.
- 2 Connect the communicator to a serial printer with the RS-232 adapter cable DLR-2.
- 3 Press **Printers** and select the correct printer driver.
- 4 Press **Start** to start printing.

## Document outbox

When you send faxes, short messages and mail, they always go first to the Document outbox. The outbox prepares your document and then sends it via the phone. If the phone is off, or the cellular signal strength is inadequate, the document will not be sent until the phone is switched on and the signal strength is sufficient. If the phone or fax called is off or busy during the first attempt, the Document outbox attempts to send the document nine more times. If the sending still fails, the communicator informs you of this with a note.

The Document outbox can be accessed in the main views of the Fax, SMS, Mail and Notes applications, where it is shown at the bottom of the folders list. To open the Document outbox, select it from the folders list and press **Open**.

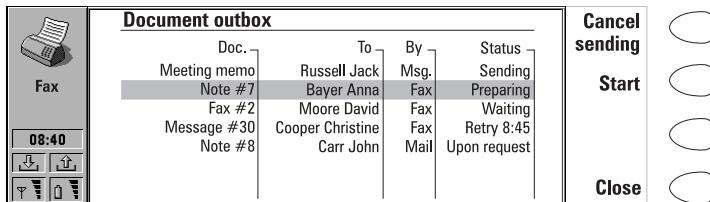

Figure 3

The main statuses that documents can have in the outbox are:

**Sending** — The document is currently being sent.

**Waiting** — The document is waiting for sending to become possible, e.g. when the phone is switched on, cellular signal strength becomes adequate, previous phone call ends.

**Retry [time]** — Sending of the document failed and it will be sent again at the time specified in the square brackets.

**At [time]** — The fax is waiting to be sent at the time you have specified. See "Fax settings" on page 72.

**Sending [current page/total pages]** — The number of the fax page that is being sent and the total number of the pages.

*Upon request* — E-mail messages may have this status if the *Send mail* setting has been set to *Upon request* in the Mail settings. See “Mail settings” on page 87. These messages will not be sent until you select one and press **Start**. All mail with the *Upon request* status will be sent during the same connection.

To speed up manually the sending of documents that have the *Waiting, Retry, At [time]* or *Upon request* status, select the document and press **Start**. The document(s) will be sent as soon as possible.

A document is removed from the Document outbox if sending succeeds or you cancel the sending by pressing **Cancel sending**.

### Received communication note

When you open the cover of the communicator and have missed calls, received faxes, short messages or mail, or there are unsent documents in the Document outbox, a note will be shown, see figure 4. The note can be dismissed by pressing **Cancel**.

To read the received documents or to check who has made the missed calls, select the corresponding item on the list and press **View**.

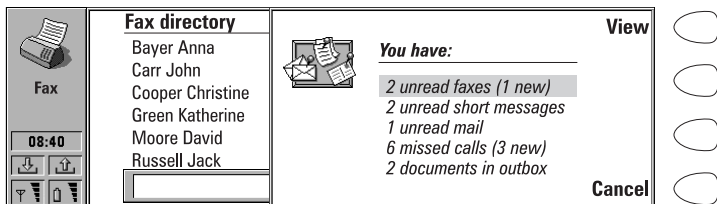

Figure 4

## To transfer data from older communicator models

If you have an English version of the Nokia 9000 Communicator or the Nokia 9000i Communicator, you can make backups of the data in it with the Nokia Communicator Server program, and restore the data to any language version of the Nokia 9110 Communicator. You can transfer data in a similar way between the same language versions, e.g. from a Finnish version of the Nokia 9000i Communicator to a Finnish version of the Nokia 9110 Communicator.

**Note:** Never restore the settings from Nokia 9000 or 9000i communicators to the Nokia 9110 Communicator.

## To transfer data between different language versions

- 1 If the languages are not compatible, e.g. if you want to transfer data from a Finnish version of the Nokia 9000i Communicator to a French version of the Nokia 9110 Communicator, move your contacts and calendar data with the Nokia Communicator Server program onto a PC using the Import/Export contacts and Import/Export calendar data applications.
- 2 Move your documents with the Nokia Communicator Server program onto a PC using the File transfer application.
- 3 Start the PC Suite for Nokia 9110 Communicator program on the PC and transfer the contacts, calendar data, and documents to the Nokia 9110 Communicator.

# 4. PC connectivity

This chapter explains how to install the PC connectivity software on a PC, how to connect your communicator to the PC, and how to use the connectivity programs.

## To use the PC Suite



*Figure 1*

You can connect your communicator to a suitable PC with the PC Suite for Nokia 9110 Communicator program. The PC Suite and its user's guide are found on the CD-ROM supplied in the communicator sales package.

The PC Suite works with Windows 95/98 and NT 4.0, and requires IBM-compatible 486 PC or higher.

When using the PC Suite, you only need to connect your communicator to a PC; everything else is done on the PC.

**Note:** Making or answering phone calls during a PC connection is not recommended as it might disrupt the operation.

## To install the PC Suite on a PC

The CD-ROM should launch itself automatically after you have inserted it into the CD drive of your PC. If not, please, follow these steps:

- 1 Click the Windows "Start" button; then click "Run".
- 2 If your PC has Windows 95, 98 or NT 4.0 (or later), type `d:\19110_95.exe` in the command line. If your PC has Windows 3.x, type `d:\19110_31.exe`. Substitute the letter "d" with the letter of the CD drive.
- 3 Press Enter.
- 4 Follow the instructions shown on the screen.

**Note:** The PC Suite for Nokia 9110 Communicator program can be found in the Menu under the heading "PC and Macintosh software".

## To use the PC Suite with an infrared connection

- 1 The IrDA software must be installed and running on the PC. To check if the IrDA driver is already installed on the PC, go to the Control Panel. If there is an icon called Infrared, the driver has been installed.
- 2 Make sure that the infrared port of the communicator faces the infrared port of the PC. Keep the infrared link clear: check the infrared indicators in the indicator area, see "Communicator display" on page 20. If the infrared link is obstructed for too long, for example, if something is moved between the infrared sensors or the communicator is moved, the operation is interrupted.
- 3 Start the PC Suite software on the PC. In the Preference dialog, select IR as the data transfer protocol, and the correct COM port.
- 4 Start the Infrared activation application on your communicator and press **Activate**. See "Infrared activation" on page 129.

## To use the PC Suite with a cable connection

- 1 Connect the 9-pin end of the RS-232 adapter cable DLR-2 to the COM port of the PC, and the other end to the connector at the bottom of the communicator. See "Connectors" on page 26.
- 2 Start the PC Suite software on the PC.

**Note:** Remember to make backup copies of all important data!

**Tip:** You can also use the optional deskstand for easy PC connectivity. See the Accessories guide.



## Contacts

The Contacts function of the PC Suite lets you create, edit and update contact cards on your Nokia 9110 Communicator, and transfer them between a PC and your communicator. To start the Contacts application, click on the Contacts icon in the main screen.

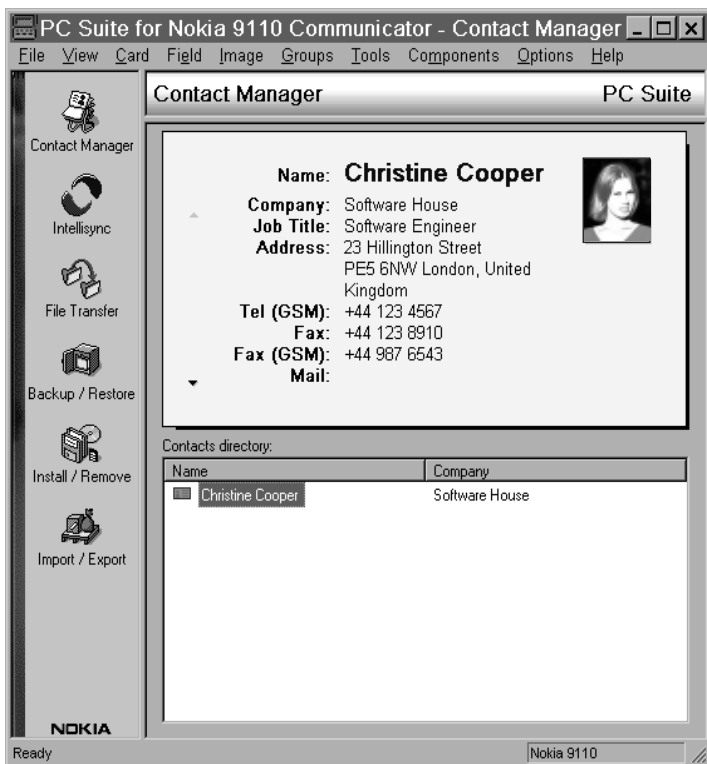

Figure 2

## Intellisync

With the Intellisync function you can synchronise data between your communicator and a PC.

- 1 Connect your communicator to the PC.
- 2 Start the PC Suite program on the PC and click the Intellisync icon in the main screen.
- 3 The Local (i.e. PC) tab is automatically selected. Click the Settings button.

**Note:** You may be presented with a dialog containing the tabs Format and File. In the Format tab, select the address format that you are using for addresses in your communicator. The Contacts Format 5 is recommended. In the File tab, indicate if you want to synchronise Contacts on the communicator memory, or on the memory card. After this, click OK.

- 4 This displays the PC Suite Configuration dialog with the Calendar, Contacts, and To-do list applications of your communicator.
- 5 Click on the communicator application you want to configure.
- 6 Click the Choose button to enter the Choose Translator dialog. The Choose Translator dialog lists all the PC applications that are compatible with the communicator application you selected.
- 7 Click the OK button in the Choose Translator dialog to return to the Configuration dialog. Now the PC application you selected appears next to the name of the communicator application.

**Note:** The first time you select Microsoft Outlook in the Choose Translator dialog, use the Browse button to locate the data in your Outlook folder which you wish to synchronise.

- 8 Specify the application and, if necessary, the file you want to synchronise.

**Note:** In order to synchronise data successfully between your communicator and a PC application, click on the Advanced button after selecting the application with which to do the synchronisation. In the Advanced settings dialog, click on Field Mapping and match the fields of the PC application with those fields of the communicator that have been marked with asterisks, see figure 3.

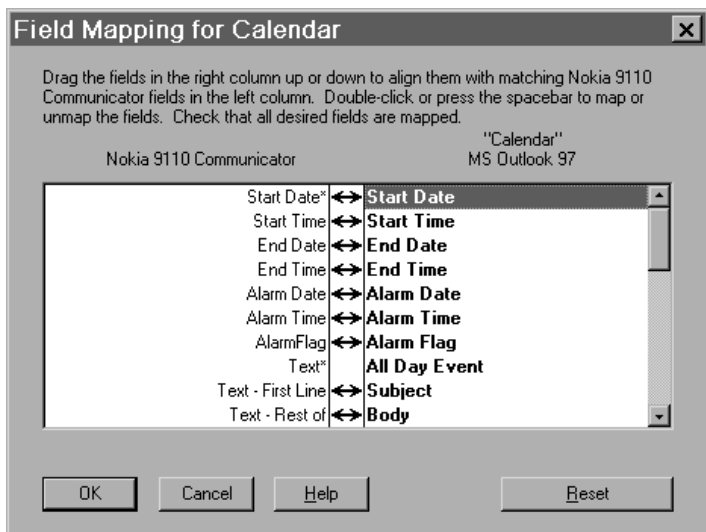

Figure 3

- 9 When you are ready to perform the operation, click the OK button at the bottom of the Configuration dialog.
- 10 Click the Synchronise button on the PC Suite opening screen.
- 11 If prompted, resolve data conflicts.
- 12 A confirmation prompt appears, showing you how many adds, changes, and deletes will be applied to each of your systems if you proceed with the operation. Click Accept to proceed, or Cancel to discontinue.

### File transfer

The File Transfer application lets you move, copy, paste, rename, and remove communicator and PC files.

**Note:** Faxes are transferred from the communicator to a PC in TIFF format; this means that you need to use Windows Imaging to view more than the first page of a fax.

- 1 Establish a connection between your communicator and a PC. See above.

- 2 Start the PC Suite program on the PC and click the File Transfer icon in the main screen.
- 3 Select an item by clicking on it in the File Transfer screen with the mouse and drag and drop it to the appropriate PC directory or communicator folder.

## Backup / Restore

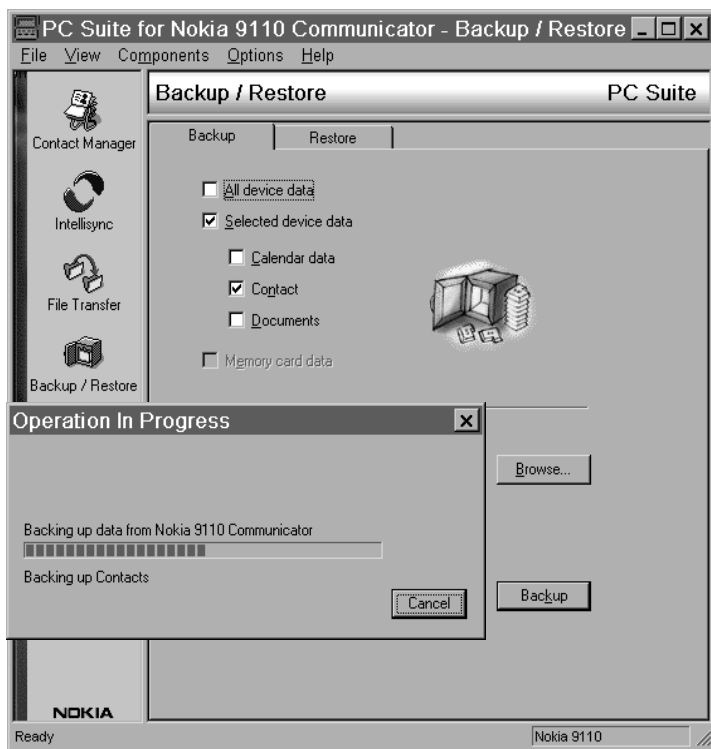

Figure 4

The Backup/Restore function enables you to create backups of your communicator data on a PC and later restore the data in the communicator.

- 1 Establish a connection between your communicator and a PC, see above.
- 2 Start the PC Suite program on the PC and click the Backup/Restore icon in the main screen.

- 3 Click on the Backup tab and select one of the following options: All device data backs up all of the data in your communicator. Selected device data allows you to select whether to backup your Calendar data, Contacts, Documents, or Settings, or select Memory card data to backup the information on your memory card.
- 4 In the "Backup Path" box, specify the location where you want the backups to be stored. The backup name is assigned automatically.
- 5 Enter a number between 1 and 99 in the "Number of backup stores" box.
- 6 Click the Backup button.

To restore data, click on the Restore tab. Specify the location of the backup in the "Backup stored in" box. In the lower box, click on the data you want to restore. Click Restore to restore the backup to your communicator.

### Install / Remove

The Install/Remove Software function lets you install and remove software from your communicator.

**Note:** If you install to the Nokia 9110 Communicator software made for the older communicator models, be aware that the greyscales of the devices are different. Therefore, the display may seem lighter. Although this difference does not affect the functioning of the software, always try to install the version made especially for the Nokia 9110 Communicator.

- 1 Establish a connection between your communicator and a PC, see above.
- 2 Start the PC Suite program on the PC and click the Install/Remove icon in the main screen.
- 3 Click the Install tab and enter the location of the software you want to install in the "Select Path" box.
- 4 Click on the software you want to install in the box below.
- 5 Click the Install button.

To remove software from your communicator, click the Remove tab. Select the software you want to remove in the box and click the Remove button.

### Import / Export

The Import/Export function can be used to transfer calendar and contacts files between your communicator and a PC.

- 1 Establish a connection between your communicator and a PC, as shown above.
- 2 Start the PC Suite program on the PC and click the Import/Export icon in the main screen.

- 3 Click the Export tab and choose one of three options: Calendar data; Contacts; Contacts File on Memory Card.
- 4 In the "Select the PC file to create" box, specify the name and path of the PC file you want to create.
- 5 Click the Export button.

To import a file from a PC to your communicator, click the Import tab and select which items to import. Specify the PC file that you want to transfer to your communicator and click the Import button.

## To use the Nokia Communicator Server

For Windows 3.11 and Apple Macintosh users the CD-ROM in the communicator sales package contains the Nokia Communicator Server program. With the Nokia Communicator Server you can install and use the communicator applications that require PC connectivity, see chapter 12 "System" on page 12-123. You need to connect your communicator to a PC and start the necessary application on the communicator.

**Note:** The English version of the File transfer, Import/export contacts, and Import/Export calendar data applications that can be used with the Nokia Communicator Server can be installed to your communicator from the diskette included in the sales package. Other language versions are found on the CD-ROM.

The Nokia Communicator Server also works with Windows 95 and NT.

**Tip:** You do not need this software if you use the PC Suite for Nokia 9110 Communicator. See "To use the PC Suite" on page 39.

### To install the Nokia Communicator Server on a PC

- 1 Insert the diskette into the diskette drive.
- 2 In the Windows Program Manager, click on the "File" menu.
- 3 Click on menu item "Run" and type `a:\server` in the command line. Substitute the letter "a" with the letter of the diskette drive.
- 4 Press Enter.
- 5 Follow the instructions shown on the screen.

**To use the Nokia Communicator Server with an infrared connection**

- 1 Follow the first two steps for installing the PC Suite.
- 2 Start the Nokia Communicator Server software on the PC.
- 3 Start the desired PC connectivity application on your communicator. Remember to set infrared as the connection type.

**To use the Nokia Communicator Server with a cable connection**

- 1 Connect the 9-pin end of the RS-232 adapter cable DLR-2 to the COM port of the PC, and the other end to the connector at the bottom of the communicator. See "Connectors" on page 26.
- 2 Start the Nokia Communicator Server software on the PC. Check that the COM port reported by the software is correct.
- 3 Start the desired PC connectivity application on your communicator. Remember to set cable as the connection type.

**Tip:** For information on how to install new software on your communicator with the Nokia Communicator Server, see "Install/Remove software" on page 132.





# 5. Contacts

The Contacts application is used for creating, editing, and managing all contact information, such as phone numbers, addresses and speed dials, and for viewing logs of all incoming and outgoing voice, data and fax calls and SMS messages.

The Telephone, Fax, SMS, Calendar and Mail applications all use information found in the Contacts directory.

**Tip:** You will find the Club Nokia Careline contact cards in the Contacts directory. Club Nokia Careline answers questions and offers instructions over the phone.

## Contacts directory

The Contacts main view shows two windows: on the left is the Contacts directory, which is a list of all contact cards, and on the right is the currently selected contact card. The active window is surrounded by a dark frame. You can toggle between the windows with the Tab key. The contact cards are listed in the Contacts directory in alphabetical order according to the name in the *Name* field of each card.

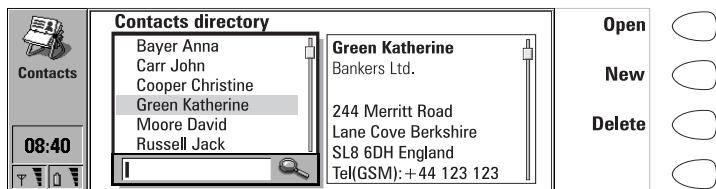

Figure 1

### To find contact cards

- 1 Move the selection frame in the Contacts directory with the arrow keys until the contact you are searching for is shown within the selection frame. Or,
- 2 Enter text into the search field. The search looks for matches in the *Name*, *Company* and *Address* fields. The search results can be cleared by removing characters one by one from the search field with the backspace key.

To open the selected contact card, press **Open**.

To remove the selected contact card, press **Delete**.

**Note:** If you have a memory card inserted in the communicator, the memory card contact databases are shown as folders in the Contacts main view. When you open a folder, you can only call and send messages to the contacts in that database.

## To use the Menu button

Pressing the Menu button in the Contacts directory opens a new set of options:

*Individual log*—Opens the Individual log of the selected contact, see “Logs” on page 55.

*General log*—Opens the General log.

*Duplicate card*—Creates a duplicate of the selected card.

*SIM card memory*—Shows the contents of your SIM card.

*Copy to SIM*—Copies the selected contact(s) to the SIM card memory.

*Create group*—Creates a new contact group, see “Contact groups” on page 54.

*List groups*—Opens a list of all contact groups.

*New contacts database*—Creates a new contacts database to the memory card.

*Rename contacts database*—You can give the memory card contacts database a new name.

*Copy contacts*—You can copy contacts to and from your memory card.

*Move contacts*—You can move contacts to and from your memory card.

*Contact info*—Shows the number of contacts and the amount of contact data.

*Settings*—Enables you to change the following settings:

*Contact card template*—You can define which fields are included in all new contact cards you create. Changes made to the template affect all new, but not existing contact cards. You cannot enter text into the fields of the template.

*Log length*—You can define how recent contacts will be listed in the General and Individual logs. Select the new log length and press **OK**. The possible values are: *Zero / 10 days / 30 days / 1 year / User defined: days* (0 – 365 days).

## To make contact cards

- 1 To make a new contact card, press **New** in the Contacts main view.
- 2 When the new contact card opens, enter the contact information in the various fields. Use the arrow keys to move from one field to another. You can add lines to the *Address* and *Note* fields with the Enter key.
- 3 To return to the Contacts directory, press **Close**.

**Tip:** When entering phone numbers into the *Tel* fields, storing a + character in front of the country code will allow you to use the same phone number abroad.

When storing phone numbers or DTMF sequences, you can use hyphens and spaces to arrange the appearance of the strings. This will not affect the way the numbers or DTMF tones will be dialled.

**Tip:** It is possible to import contacts from a PC or certain handheld devices by using the IntelliMigrate program on the CD-ROM supplied in the sales package of the communicator.

## To add new fields to a contact card

- 1 Press **Fields** in the currently opened contact card. See figure 2.
- 2 Press **Add field**. A pop-up box opens, listing the available fields.
- 3 Select a field and press **OK**. There can only be one *Name*, *Job title*, *Company*, *Note* and *Password* field.

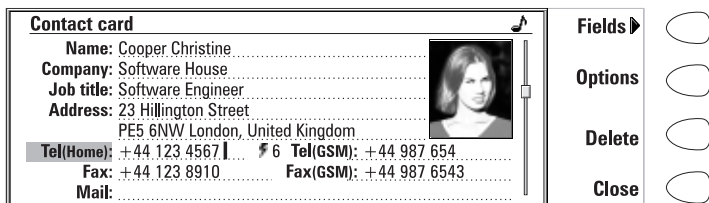

Figure 2

**Note:** The *Tel/Fax* field is for alternating calls, the *Tel(Server)* field for sending bookings to remote calendar servers, and the *Password* field for the calendar booking password. See "Multiple calls" on page 60, and "Calendar booking" on page 119.

### To customise the label of a field

- 1 Press **Fields** in the currently opened contact card.
- 2 Select a field and press **Change label**.
- 3 Select one of the predefined labels or scroll down to the field with a dotted line and write the label text, e.g. *Modem*, and press **OK**.

To remove the selected field, press **Delete field**. The *Name* field cannot be removed.

**Note:** Remember to put wireless phone numbers into the *Tel(GSM)* fields of the contact cards. Otherwise you cannot send SMS messages to these numbers.

### Contact card options

When you press **Options** in an opened contact card, the following options become available:

*Ringling tone* — You can set a specific ringing tone for each contact in the Contacts directory. Select a tone from the list, and press **Select**. The 📞 icon appears at the top of the contact card. See figure 2. In order to use this function, however, the Individual ringing tones setting must first be set on. See "Telephone settings" on page 63.

*Attached image* — You can attach a picture of the contact to the contact card. You can then send the picture with a business card, and the picture is shown on the display when the person calls you.

The picture must first be stored in JPG format in the Contact images subfolder of the Downloaded files folder, where it is then selected. Choose a picture and press **OK**.

When a picture is attached to a contact card, it is automatically adjusted to the proper size. If there is an old picture in the contact card, it will be replaced by the new picture. If you want to keep the original picture, make a copy of it and give it a different name, or move the copy to another folder, before you attach the new picture.

**Note:** If you want to attach a picture to a contact card located in the contacts database of the memory card, the picture must first be stored in the Contact images folder of the memory card.

*Speed dials*— You can set a speed dial number for the selected contact card.

### To set speed dials

Speed dialling is a quick way to call frequently used phone numbers. You can assign speed dials to eight phone numbers. Number 1 is reserved for calling your voice mailbox. For information on how to use the speed dials, see "To use speed dialling" on page 149.

- 1 Press **Options** in an opened contact card and select *Speed dials*. All phone number fields of the contact card are shown.
- 2 Select a field to which you want to assign a speed dial and press **Change**.
- 3 Select a number and press **OK**. The speed dial number will be shown in the contact card with the icon . See figure 2.

### To change or remove speed dials

- 1 Select the speed dial you want to change or remove and press **Change**.
- 2 Move the selection frame to the new location and press **OK**. If you want to remove a speed dial location, choose *None*.

### To store DTMF tones

For information on how to send DTMF tones, see "Multiple calls" on page 60, or "To send DTMF tones" on page 150.

If you need both a voice and a DTMF phone number for the contact, store the DTMF sequence in the *Te*/field, in which case the phone number and the DTMF sequence must be separated by one of the special characters in table 1. Or add a *DTMF* field to the contact card with the **Add field** command.

Character	Function
* and #	May be used if the DTMF service requires them.
p (pause)	Inserts a pause of 2.5 seconds in front of, or between, DTMF digits.
w (wait)	When the "w" character is stored in a sequence, the rest of the sequence is not sent until you press <b>Send</b> again in the Telephone application.

Table 1

## To use the Menu button

Pressing the Menu button in an opened contact card opens a new set of options:

*Duplicate card* — Creates a copy of the current card.

*Copy contents* — Copies the contents of the card to a clipboard. You can add this information to documents by pressing Ctrl-V.

*Next card* — Opens the next contact card in the directory.

*Previous card* — Opens the previous contact card in the directory.

*Fetch* — If you have selected the *URL* field of a contact card with the selection frame, pressing *Fetch* starts the WWW application and opens a connection to the first URL address in the field.

*Belongs to groups* — Shows all the groups of which the current contact is a member.

## To view the contact information on your SIM card

1 Press the Menu button in the Contacts directory, and select the *SIM card memory* option.

2 Select the contact with the selection frame and press **Open**.

To add a new contact to the SIM card memory, press **New**.

To remove the selected contact(s) from the SIM card memory, press **Clear**.

To return to the Contacts main view, press **Close**.

If you press the Menu button in an opened SIM contact card, the following options become available:

*Sort by name/Sort by location* — Arranges the contacts in alphabetical order or in the order of their memory location.

*Copy SIM contacts* — Copies the selected contact(s) to the Contacts directory.

*SIM info* — Shows the amount of data in the SIM card memory.

**Note:** The SIM card cannot be accessed if the Fixed dialling function is on. See "Settings (Menu 4)" on page 157.

## Contact groups

You can create contact groups in order to be able to send mail or short messages to a group of people at the same time. See figure 3.

### To create a group

1 Use multiselection in the Contacts directory to select the contacts you

want to include in the group.

- 2 Press the Menu button and select the *Create group* option

You can also create an empty group by pressing the Menu button and selecting *Create group*, and add members later. See below.

When you close a new group contact card for the first time, you will be asked to enter the name of the group.

### To add new contacts to a group

- 1 Open the group contact card and press **Add**. A list of contacts opens.
- 2 Select the contact(s) you want and press **Add**.

To remove contacts from a group, open the group contact card, select the contact(s) to be removed and press **Remove**.

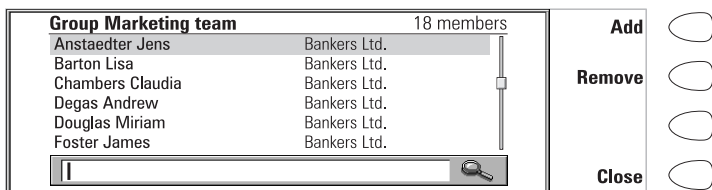

Figure 3

### To use the Menu button

When you press the Menu button in an opened group contact card, the following options become available:

*Rename group* — Allows you to give the group a new name.

*Belongs to groups* — Shows all the groups to which the selected contact belongs.

*List of groups* — Opens a list of all contact groups.

## Logs

The Contacts application shows all communication events as two logs: the General log shows all, or certain types of, communication events in chronological order. The Individual log shows a list of all communication events relating to the selected contact.

**Note:** Remote mailbox, Terminal and Internet connections are logged as data calls.

**To access the logs**

- 1 Press the Menu button in the Contacts directory.
- 2 Select either *Individual log* or *General log*.

**To erase the contents of the log**

- 1 Press **Clear list**.
- 2 A pop-up box opens to let you define how old communications you want to remove. The clearing procedure reflects on the other log as well.

**To make a new contact card**

- 1 Open the General log.
- 2 Select a log event and press **Create card**. If the contact card already exists, the command is dimmed.

**To view only certain communication types**

- 1 Open the General log and press **Filter**.
- 2 Select the communication type you want to view and press **OK**.



# 6. Telephone

The Telephone application is started by pressing the Tel. application button on the keyboard. Some of the operations explained here can also be made via the phone.

You can have two separate phone lines, see "Telephone settings" on page 63.

**Note:** Opening or closing the cover does not affect active phone calls. If you have made a voice call via the phone and you open the cover, the Telephone application starts automatically. You can continue the call after pressing **Audio on**. See "Handsfree mode" on page 59.

## To make a call

In order to make phone calls, a valid SIM card must be inserted and the phone must be switched on. There are three ways to make a call.

**Note:** When making a call, make sure that the antenna at the top of the communicator is up.

### To make the call manually

- 1 Enter the telephone number in the search field.
- 2 Press **Call**.

### To call a number in the Telephone directory

When you have no active voice calls, the Telephone main view shows the Telephone directory, see figure 1. Contact cards that do not contain any phone numbers appear dimmed in the directory and cannot be selected.

- 1 Select a contact in the Telephone directory either by scrolling or by using the search field.
- 2 Press **Call**. If the contact has more than one phone number, a pop-up box opens, listing all the contact's phone numbers. Choose a number from the list and press **Call**.

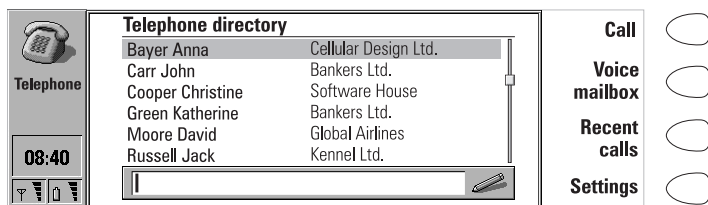

Figure 1

## To call a number in the Recent calls list

- 1 Press the **Recent calls** command.
- 2 Select the Dialed, Received or Missed calls list and press **Open**.
- 3 Select a number from the list and press **Call**.

**Tip:** When you open the Dialed, Received or Missed calls list and select a contact, **Create card** enables you to make a contact card for the contact.

Once you have made the call, you can close the cover and continue the call with the phone, unless you want to use the handsfree option, see "Handsfree mode" on page 59.

## To use the Menu button

When you press the Menu button in the Telephone directory, the following options become available:

*SIM card memory* – Displays the memory locations on the SIM card.



*Show call costs* – You can check the cost of your previous calls.

## To answer a call

- 1 When you receive a call while having the communicator cover open, a note about the incoming call is shown on the display. If you are called by a person who has a contact card in your Contacts directory, as in the figure 2, the caller's name is shown on the note, if this feature is supported by the network. To answer the call, press **Answer**. Or,
- 2 Close the device cover and answer the call via the phone by pressing .

**Note:** You cannot have two active calls at the same time. If the Call waiting network service is activated in your SIM card, the active call is automatically put on hold when you answer the new incoming call.

If you do not want to take the call, press **End call** or . The caller will hear the alerting tone change to a "line busy" tone.

**Tip:** If you do not want your communicator to alert, a quick way to make the communicator silent is to close the cover and press the  key on the phone. Press the key again until the selection frame is on the Silent profile. To select the profile, press and hold .

## To use the Menu button

If you press the Menu button while having a call active, the following options become available:

*Send DTMF* — Allows you to send DTMF tones. Select one of the predefined sequences, or enter a new sequence in the input field.

*Voice recorder* — Enables you to record voice memos. See "Voice recorder" on page 142.

*More info* — Allows you to view the other party's contact card and individual log.

*Settings* — Enables you to change the Telephone settings, see "Telephone settings" on page 63.

## Handsfree mode

When you have a call, the handsfree mode allows you to speak and listen to the communicator from a short distance when the cover is open. This function is not available when the cover is closed.

The Telephone setting *Audio when cover opened* determines whether the handsfree mode is activated automatically after you open the cover. To set the handsfree mode on manually, press **Audio on**.

After the audio has been set on, the command changes to **Volume**. Press **Volume** to adjust the speaker volume or to turn the audio off. The indicator shows the chosen volume level.

## Multiple calls

When you have made a call, information about the call is shown on the display. In addition to the active call, you can have a call on hold and a waiting call at the same time. The conference call, which can accommodate up to five remote participants, is handled as a single call.

To switch between multiple calls, use the arrow keys. The command buttons change according to the status of the selected call. For example, a call on hold can be changed to an active call by pressing **Activate**.

The call within the dark frame is selected      Call cost counter

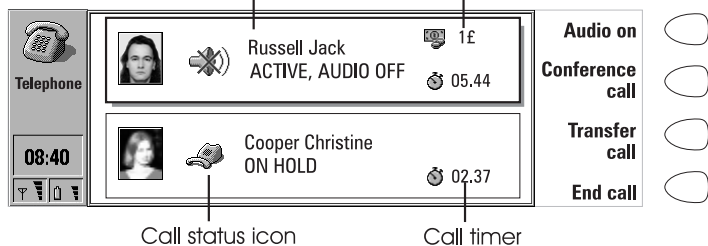

Figure 2

The call information may include the following (see figure 2):

The name or phone number of the caller and a picture, if available.

The status of the call: active, on hold, waiting, or conference, and whether the audio is off.

The call timer displays how much time has expired since the beginning of the call. The timer also counts the time spent on hold.

The call cost counter shows the cumulative cost of the call, if this network service is available and the call cost setting is on. You can determine whether to calculate the call costs in currency or charging units in the Telephone settings, see "Telephone settings" on page 63.

To end a call, select the call with the arrow keys and press **End call**.

**Note:** The actual invoice for calls and services from your service provider may vary, depending upon network features, rounding-off for billing, taxes and so forth.

### To make a new call

- 1 If you already have an active call and a call on hold, drop one of the calls or merge them into a conference call.
- 2 Press **New call** and make the new call normally. The previous call will be put on hold.

### To make a conference call

The conference call is a network service. Contact your network operator to check if this service is available. In a conference call, you and up to five remote persons can hear each other simultaneously.

- 1 Make the first call normally.
- 2 Once this person has answered, make a call to the second participant by pressing **New call**. The first call is put on hold.
- 3 Wait until the second person answers the call.
- 4 To include the first participant in the call, press **Conference call**. If you want to include a new person in the conference call, repeat this operation.
- 5 When all participants have been included in the conference call, the best voice quality is achieved by closing the cover and continuing the call via the phone.

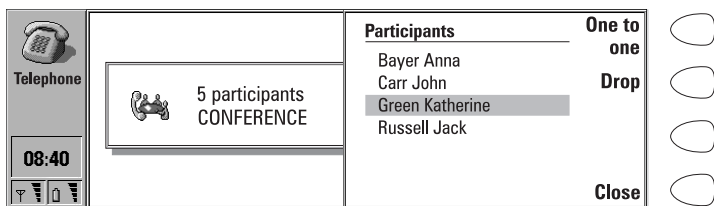

Figure 3

### To end the call with a conference call participant

- 1 Press **Conference commands**.
- 2 Select the caller from the list of participants (figure 3) and press **Drop**.

### To talk privately with one of the conference call participants

- 1 Press **Conference commands**.
- 2 Select a participant from the list and press **One to one**. The call is now split into two: the conference call is on hold and the one-to-one call is active.
- 3 Once you have finished the private conversation, you can connect the person back into the conference call by pressing **Conference call**.

## To transfer calls

The call transfer is a network service which enables you to connect two calls together and disconnect yourself from both calls.

- 1 When you have one call on hold, and another call active or an outgoing call alerting, press **Transfer** to connect the calls together.

**Note:** Calls can be transferred only if all calls are voice calls, not fax or data calls, and none of the calls is a conference call.

## To answer a waiting call

Call waiting is a network service to which you must subscribe before you can use it. Call waiting is set on in the Telephone settings, see "Telephone settings" on page 63.

- 1 When you receive a new call while you already have an active call, you will hear a sound and see a note informing you of the new incoming call.
- 2 Press **Answer**. The previous call will be put on hold.

## To send DTMF tones when you have an active call

- 1 Key in the digits from the communicator keyboard. Each keystroke will generate a DTMF tone which will be transmitted directly.  
Besides the numbers 0 - 9, you can also use the characters **p**, **w**, **\*** and **#** when sending DTMF tones. For information on the functions of these characters, see "To make contact cards" on page 51.

Or alternatively,

- 1 Press the Menu button and select *Send DTMF*. The DTMF sequences stored in the other party's contact card are shown. For information on how to store DTMF sequences, see "To make contact cards" on page 51.
- 2 Select a DTMF sequence. You can edit the sequence, or, if there are no stored sequences, you can write a new DTMF sequence into the input field.
- 3 Press **Send**.

**Tip:** You cannot access the stored DTMF sequences during a conference call. However, you can send DTMF tones during a conference call by keying in the digits from the keyboard.

## To make alternating calls

An alternating call is made as a voice call, but it changes into a fax call. An alternating call can be made to a fax box, for example: you initiate the call as

a voice call, but it changes into a fax call when your fax box starts to send you your faxes.

To make alternating calls, you need to add a special *Tel/Fax* field to the contact cards of the recipients of your alternating calls. See "To make contact cards" on page 51.

You can also change the mode of the call from voice to fax manually by pressing **Change call mode**.

Alternating calls cannot be put on hold or incorporated into a conference call.

## Telephone settings

Press **Settings** in the Telephone main view to open a list of several settings groups.

### To change the settings

- 1 Select a settings group and press **Change** to open it.
- 2 Select a setting and press **Change**. The current value of the setting is displayed after the setting name, unless the setting is one the network services: call diverting, barring or waiting. See the following sections.

### Profile settings

The profile settings are used for selecting the operating environment for the communicator, and for modifying the profile features. One profile is always in use.

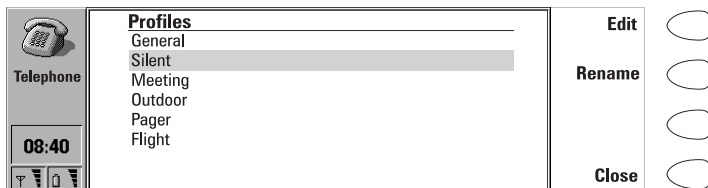

Figure 4

*Profile in use* — Press **Change** and select the profile you want to use. Press **OK**.

*Profiles* — With this setting you can modify the profiles. The available profiles are:

*General* — The normal profile of the communicator.

*Silent* — You can set this profile on when you want all the alert tones to remain silent.

*Meeting* — You can specify how the communicator operates when you are in a meeting.

*Outdoor* — You can specify how the communicator operates when you are outdoors.

*Pager* — You can set this profile on, when you want the communicator to act as a pager, i.e. the ringing tone is silent and only received SMS messages alert.

*Flight* — Sets on the flight profile, see "Flight profile" on page 67.

*Car* — The car profile is set on automatically when the communicator is connected to a car kit.

*Headset* — The headset profile is set on automatically when a headset is connected to the communicator.

Press **Rename** to change the names of the profiles.

Press **Edit** to modify the following features of a profile:

*All alert tones* — You can set the incoming call alert and other alarms to:

*Ringing* — The normal alert tone is used.

*Ascending* — The normal alert tone is used, but the volume of the tone increases gradually.

*Ring once* — The alert tone sounds only once.

*Beep once* — A single beep is heard when you receive a call or a message.

*Caller groups* — The alert tone will only sound when you receive a call from a member of the selected caller group. See below.

*Silent* — All the sounds, except the alarm clock, are turned off.

Whatever the chosen setting, an incoming call is always indicated by a note.

*Ringing volume* — Adjusts the ringing volume: 1 is the lowest, 5 the highest.

*Ringing tone* — Determines the ringing tone. To compose your own ringing tones, see "Composer" on page 139, and to record a ringing tone with the Digital voice recorder, see "Voice recorder" on page 142.

*Communicator key click* — Sets the communicator keyboard sound to *Off*, *Type 1* or *Type 2*.

*Phone key click* — Adjusts the phone keypad sound: 1 is the lowest, 3 the highest, *Off* turns off the keypad sound.

*Divert all voice calls* — You can divert all your incoming voice calls to another phone number. The option *Default diverts* uses the diverts set in the Network settings. See below.

*Phone lights* — The phone display and keypad lights are either permanently on, or they remain on for the pre-set time period. Available in the car profile only.

*Automatic answer* — All calls are automatically answered. Available in the car profile only.

*Caller groups* — Set one or several contact groups to *Yes*, and only those messages, calls, faxes etc. that come from people belonging to these groups, alert.



## Call settings

*Own number sending* — You can select whether to keep your phone number hidden from the recipients of your phone calls. Do not use this function unless it has been activated for your SIM card.

*On* — Your number is shown to all the recipients of your calls.

*Off* — Your number is hidden from all the recipients of your calls.

*Preset* — The value stored in the network is used.

*Next on* — Your number is shown to the recipient of your next call.

*Next off* — Your number is hidden from the recipient of your next call.

*Call cost settings* — You can set on the call cost counter and modify its settings. Changing the settings requires the PIN2 code.

*Audio when cover opened* — Determines whether the handsfree mode is set on automatically after you open the cover.

*Call timer display* — If set to *On*, the call timer is shown during calls.

*Automatic redialling* — When this function is set on and you call a number that is busy or does not answer, the communicator will attempt to call the number until the call is connected.

*Phone line in use* — If your network and SIM card support this feature, you can have two different subscriptions for voice calls. These subscriptions are referred to as Line 1 and Line 2. Each line may have separate settings for some functions. With this setting, you can determine which phone line is currently in use for all outgoing calls.

*Default call mode* — In some networks you have the same phone number for all your voice, fax and data calls. If you want to receive any calls, you must set your phone to some answering mode. The available modes are *Voice*, *Fax*, *Data* and *Voice/Fax*.

## Network settings

The network services may not be supported by all operators, or you may have to subscribe to them.

Information about the status of these services is stored in the network. Therefore, the current settings are not shown until you request the information from the network by pressing **Get status**.

While the communicator is making a request to the network, a query note is shown on the display. After a successful request, the new status now appears in the settings list.

To cancel all call diverts or barrings, press **Cancel call diverts** or **Cancel call barrings**.

*Voice call diverting* — This network service allows you to direct your incoming voice calls to another phone number.

- 1 Choose a divert option:
  - Divert all calls*— All incoming calls are diverted.
  - Divert when phone is busy*— Incoming calls are diverted when the phone is busy.
  - Divert when not answered*— Incoming calls are diverted when you do not answer them. *Delay* allows you to choose the time period after which the call is diverted. The available time periods are 5, 10, 15, 20, 25 and 30 seconds.
  - Divert if not reachable*— Incoming calls are diverted when the phone is switched off or outside the network service area.
- 2 Press **Change**, and select one of the following options:
  - To*— Enter the number to which you want to divert the calls.
  - To voice mailbox*— Calls will be diverted to your voice mailbox. The phone number of the voice mailbox must be set in Other settings.
  - Off*— Calls are not diverted.

**Note:** If you have subscribed to the Alternate phone line service, this setting applies only to the selected phone line.

*Voice call barring*— This network service enables you to restrict outgoing and incoming voice calls. If you take the call barring into use or change the barring settings, you will need the barring password, which you obtain from the network operator. The available options are:

*All outgoing calls*— Calls cannot be made.

*All international calls*— Calls cannot be made to foreign countries.

*International except home country*— Calls can be made only within the current country and to your home country, i.e. the country where your network operator is located.

*All incoming calls*— Calls cannot be received.

*Incoming calls when abroad*— Calls cannot be received when you are outside your home country.

**Note:** When security features which restrict calls are in use (call barring, call diverting), calls may be possible to certain emergency numbers in some networks (e.g. 112 or other official emergency number).

*Call waiting*— When this network service is set on, the network will notify you of a new incoming voice call while you have an active call. You will hear a

sound and see the caller's name or phone number, and the text WAITING on the display.

## Other settings

*Voice mailbox number* — Set a new or change the phone number of your voice mailbox. You can call your voice mailbox by pressing **Voice mailbox** in the Telephone main view.

**Note:** Your network operator may be able to update your voice mailbox number via a special SMS message. Contact your network operator for details.

*Individual ringing tones* — You can set the individual ringing tones function on or off. See "To make contact cards" on page 51.

## Flight profile

The flight profile prevents you from accidentally turning on your phone in an aircraft.

### To set on the flight profile

- 1 Press **Settings** in the Telephone main view.
- 2 Choose *Profiles* and press **Change**.
- 3 Scroll to *Profile in use*, press **Change** and select *Flight*.
- 4 Press **OK**.

With the flight profile active, you may read previously downloaded mail, write mail, notes, short messages, faxes, or update your calendar. Once you have left the aircraft, you can turn off the flight profile by pressing **Exit profile**, turn on the phone by pressing **⓪**, and your short messages, faxes and mail will be sent automatically.

When the communicator is in the flight profile, emergency calls must be made from the phone:

- 1 Press **⓪**. The phone display will read FLIGHT PROFILE ACTIVE.
- 2 While the FLIGHT PROFILE ACTIVE text is visible (for approximately five seconds) you can dial the emergency number, e.g. 112.
- 3 Press .

**IMPORTANT!** Never use the phone when in an aircraft. If the aircraft personnel allow use of the communicator interface, you **MUST** activate the flight profile. The flight profile will allow use of the communicator interface only and will prevent use of the phone.

Be aware that all communications applications, Telephone, Fax, SMS, Mail, and Internet, require use of the phone.

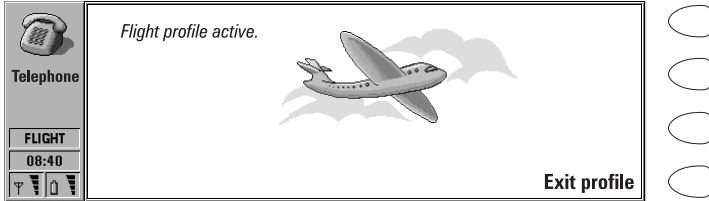

Figure 5

# 7. Fax

Fax is started by pressing the Fax application button on the communicator keyboard.

To send and receive faxes, the phone must be on; the network you are using must support fax calls; and the fax service must be activated for your SIM card. Contact your home service provider for details.

When a fax is being sent or received, the FAX indicator appears in the indicator row of the display.

**Note:** Voice calls cannot be made or received when a fax is being sent or received.

The Fax main view shows:

Own texts folder — Contains all created faxes, short messages, memos, notes and mail stored on the communicator.

Received faxes folder — Contains all received faxes.

Document outbox — See "Document features" on page 34.

## To send faxes

### To write a new fax

- 1 Press **Write fax** in the Fax main view.
- 2 Write the fax.
- 3 Press **Recipient**. The Fax directory opens.

### To send your own text as a fax

- 1 Select the Own texts folder in the Fax main view and press **Open**.
- 2 Select a document and press **Open**.
- 3 Press **Recipient** to access the Fax directory.

### To forward a received fax

- 1 Select the Received faxes folder in the Fax main view and press **Open**.
- 2 Select a fax and press **Open**.
- 3 Press **Forward** to access the Fax directory.

**Tip:** **Forward options** allows you to select the specific pages you want to send: *All, This page, or Pages*. Choose *Pages* to enter the page numbers, first through last, e.g. 3-5, that you want to forward.

## To select a recipient

- 1 Select a contact in the Fax directory and press **Select**. See figure 1. The names of contacts who have no fax number are dimmed and cannot be selected.
- 2 If the selected contact has several fax numbers, a pop-up box opens. Choose a number from the list and press **Select**.

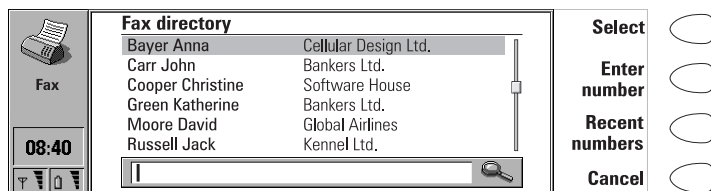

Figure 1

If there is no contact card in the Contacts directory for the recipient to whom you are sending the fax, press **Enter number** to enter the fax number manually, or obtain the information from the Recent numbers list by pressing **Recent numbers**. The list contains the fax numbers with which you have recently had contact. Choose a number and press **Select**.

**Tip:** If you press **Clear both lists** in the Recent numbers view, all information in the lists is removed. When you open one of the lists and select a contact, **Create card** enables you to create a contact card for the contact.

## Fax cover page and send options

The fax cover page contains three fields, see figure 2. You can edit the entries in all the cover page fields. The *From* field is always filled automatically according to the User data card in the System application. See "User data" on page 128.

To adjust the fax sending options, press **Send options**. The send options are: *Cover page, Send resolution, Logo file, Signature file, Begin sending, Resend, and ECM*. For more information, see "Fax settings" on page 72. To change an option, select it and press **Change**.

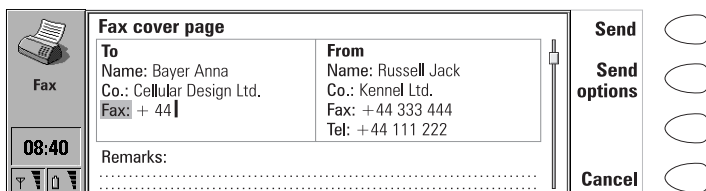

Figure 2

To send the fax, press **Send**. The fax is handed over to the Document outbox, which will send the fax as soon as possible.

**Note:** In case the sending fails, be sure to save all your important faxes.

## To receive faxes

Faxes are received automatically, provided that this service is available and that the phone is on and within cellular coverage. All received faxes go to the Received faxes folder.

If you do not wish to receive the fax, close the cover and press .

When a new fax has been received, you will hear a tone - unless the system is set to a silent profile - and an information note is shown on the display.

### To read a received fax

There are two ways to read a received fax:

- 1 When you receive a note informing you that you have received a fax, press **View**. Or,
- 2 Press **Cancel** to dismiss the note. You can then open the Received faxes folder, where unread faxes are marked with . Select the fax and press **Open**. The fax viewer opens.

You can use the up and down arrow keys to scroll the fax. The left and right arrow keys can be used for horizontal scrolling.

To remove the viewed fax, press **Delete**.

**Tip:** A list of shortcuts for viewing faxes and other operations can be found in "Document features" on page 34.



Figure 3

### To zoom the viewed fax

- 1 Press **View**. A new set of commands becomes available. See figure 3.
- 2 Each press of **Zoom in** enlarges the document on the display. The fax can be scrolled horizontally with the left and right arrow keys.  
Each press of **Zoom out** reduces the image.  
Each press of **Rotate** rotates the fax 90 degrees clockwise with each press of the command button.

To return to the previous commands, press **Back**.

**Tip:** You can also use the Zoom button to magnify the fax on the display.

### To print the viewed fax

- 1 Press the Menu button.
- 2 Select **Print**.

**Tip:** You can transfer received faxes to a PC with the PC Suite program. Please note, however, that these faxes will be converted to the TIFF format. To view all the pages of a fax on a PC, use a graphics program (e.g. Windows Imaging).

## Fax settings

Press **Settings** in the Fax main view to change the settings of all your faxes.

**Cover page** – Provides you with the following options:

**Header** – The cover page contents will be attached to the beginning of the first fax page.



*Separate page*— Only the cover page contents are shown on the first page of the fax.

*None*— No cover page information will be attached to the fax. The first page of the document will be the first page of the fax.

*Begin sending*— Lets you choose when the fax is sent:

*Immediately*— The fax is sent right away.

*At [time]*— You can determine the time when the fax is sent. Use the time format *hh:mm*. This option enables you to take advantage of cheaper calling times.

*Receive resolution:*

*Standard*— The fax will be received using 200 (width) x 100 (height) dots per inch (dpi) resolution.

*Fine*— (200 x 200 dpi). Receiving faxes with fine resolution will take longer and requires approximately twice as much memory as with standard resolution.

*Send resolution:*

*Standard*— 200 x 100 dpi.

*Fine*— (200 x 200 dpi). Sending faxes with fine resolution takes longer and temporarily requires more free memory than when using standard resolution.

*Logo file*— Enables you to add for example the logo of your company to the fax cover page. The logo file must first be stored in the GIF or JPG format in the Downloaded files folder. The logo is not shown on the display.

*No image*— No logo is attached to the fax.

*[File name]*— All the available files in the Downloaded files folder are listed in the pop-up box. Select the one you want to attach to the fax.

*Signature file*— Allows you to add your signature to the fax cover page. The signature file must first be stored in GIF or JPG format in the Downloaded files folder. The signature is placed under the *Remarks* field, but not shown on the display.

*No image*— No signature is attached to the fax.

*[File name]*— All the available files in the Downloaded files folder are listed in the pop-up box. Select the one you want to attach to the fax.

*Fax call barring*— This network service allows you to place restrictions on outgoing and incoming faxes.

*Fax call diverting*— This network service allows you to divert incoming faxes to another fax machine. For more information and instructions on how to change diverting and barring settings, see "Telephone settings" on page 63.

*Resend* — Allows you to choose which pages will be sent again if the fax sending has failed and the Document outbox tries to send the fax again.

*All pages* — All pages are resent.

*Missed pages* — Only the pages which were not sent completely are resent.

*ECM* — When the Error Correction Mode is *On*, any pages containing errors are automatically received again, until the defects are corrected.

*Fax polling* — Some networks provide this service which allows you to make a fax call to a fax machine, then receive information by fax. Contact your network service provider for further details.

**Note:** When you set *Fax polling* to *On*, **Fax polling** becomes one of the commands in the Fax main view.

*Alternate fax receiving* — As a default, this setting must be set to *As fax*. If your network requires you to receive alternate voice/fax calls, you must set this to *As voice/fax*. This setting applies also to the Fax modem application.

# 8. Short messages

The Short Messages application is started by pressing the SMS application button on the keyboard.

The Short Message Service (SMS) enables you to send and receive short text messages of up to 160 characters over the digital cellular network. If the message is long, it will be sent as several short messages.

To send and receive short messages, the Short Message Service must be supported by the network you are using and activated for your SIM card; the SMS message centre number must be stored in the settings of the SMS application; and the phone must be on. Contact your home service provider for details.

SMS messages can be sent or received even during a voice or data call. Messages can be read in any wireless phone that has the capability. If the receiving phone is off at the time of sending, the SMS message centre continues to attempt to send the message until the validity period allowed by the network expires.

The SMS main view shows the following folders:

Own texts – Texts that you have written.

Received messages – Messages that you have received.

Standard messages – Predefined message templates.

Business cards – All contact cards in the Contacts directory.

Info messages – Informative messages sent by the network.

Delivery reports – Information about the status of sent messages.

Document outbox – See "Document features" on page 34.

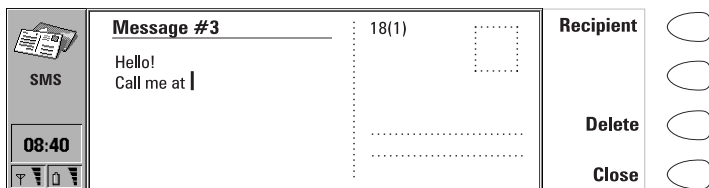

Figure 1

## To send short messages

### To write a new short message

- 1 Press **Write message** in the SMS main view to open the short message editor, which resembles a postcard. A character counter showing how many characters you have typed and in how many messages they will be sent appears at the top of the postcard, see figure 1.
- 2 Write the message.
- 3 When the message is ready to be sent, press **Recipient**. The SMS directory opens.

**Note:** You can only send short messages to wireless phone numbers stored in the *Tel(GSM)* field of contact cards.

### To send a previously written document

- 1 Select the Own texts folder and press **Open**.
- 2 Select a document and press **Open**. When you open a text containing formatting, you will be asked whether you wish to make a copy of the text (press **Copy**), or edit the original text (press **Edit**). Editing will lose the formatting of the original text.
- 3 When the message is ready to be sent, press **Recipient**. The SMS directory opens.

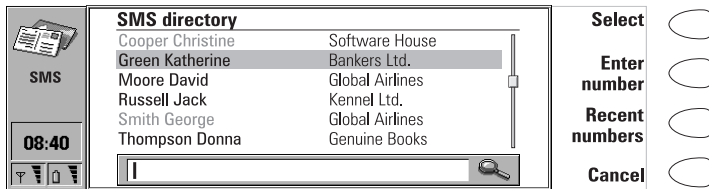

Figure 2

### To select a recipient

There are three ways to select a recipient for your short message:

- 1 Select a contact in the SMS directory, and press **Select**. Or,
- 2 Press **Enter number** and enter the phone number manually. Or,
- 3 Press **Recent numbers** to get a list of recent short message numbers, open one of the lists, select a contact, and press **Select**.

**Tip:** If you press **Clear both lists** in the Recent numbers view, all information in the lists is removed. When you open one of the lists and select a contact, **Create card** enables you to create a contact card for the contact.

If you want to add more recipients to the message, press **Add recipient**.

If you want to select the recipients from your SIM card, press the Menu button, select *SIM card memory*, and choose the recipients.

**Tip:** To send the message to several recipients, use multiselection, see "Document features" on page 34, or create a contact group, see "Contact groups" on page 54.

### To send the message

- 1 If necessary, adjust the sending options for the current message by pressing **Send options**. Press **Change** to set a new value for the current message. The send options, *Reply via same centre*, *Validity period*, *Message centre in use*, *Message conversion* and *Request delivery report*, are the same as in the SMS settings, see "SMS settings" on page 80.
- 2 Press **Send**. If your message is longer than 160 characters, it will be sent as several short messages, provided that your network supports this feature.

## To receive messages

Short messages are received automatically, provided that this service is available and that the phone is on and within network coverage. A received short message can be a normal short message, business card or a service card. All received short messages go to the Received messages folder.

When a new short message has arrived, a tone will sound – unless the device is set to a silent profile – and an information note is shown on the display.

When you open a received message, the stamp on the right half of the message is postmarked, and the time and date the message was sent are shown below the sender's name or number.

### To read a message

There are two ways to read a received message:

- 1 When you receive a note informing you of a received short message, press **View** to read the message. Or,
- 2 Press **Cancel** to dismiss the note. You can then open the Received messages folder where unread received messages are marked with 

and unread received business cards with . Select the message and press **Open**.

### To reply to a received message

- 1 Select the Received messages folder and press **Open**.
- 2 Open the selected document and press **Reply**. The contents of the received message are not included in the new message automatically. If you want to include them, press the Menu button and choose the *Reply (include text)* option.
- 3 Write the message and press **Send**.

### To forward a received message

- 1 Select the Received messages folder and press **Open**.
- 2 Open the selected document, press **Forward**. The contents of the received message are included in the new message.
- 3 Press **Recipient** and select a recipient from the SMS directory.
- 4 To send the message, press **Send**.

### To use the Menu button

When you press the Menu button in an opened received message, you can also use the following options:

*Find number* — If the message contains phone numbers, press **Next number** to toggle between these numbers and to select one of them. Press **Call** to make a phone call to the number.

*Reply (include text)* - Replies to a SMS message and includes the received SMS in your reply.

*Find URL* — If the message contains URL addresses, press **Next URL** to toggle between these addresses and to select one of them. Press **Fetch** to start the WWW application and to open a connection to the selected address.

*Print* — Prints the message.

### Service cards

A DTMF service provider may send DTMF sequences to its subscribers in the form of a service card that can be stored in the Contacts directory. For more information on DTMF tones, see "To send DTMF tones" on page 150.

## Standard messages

You can store frequently used short messages as standard messages, and send them instead of writing a new message every time. Standard messages are stored in the Standard messages folder.

To write a new standard message, open the Standard messages folder and press **Write message**. The commands in a new standard message are:

**Recipient**— Opens the SMS directory.

**Delete** — Removes the standard message from the Standard messages list.

**Close** — Returns to the Standard messages folder.

## Business cards

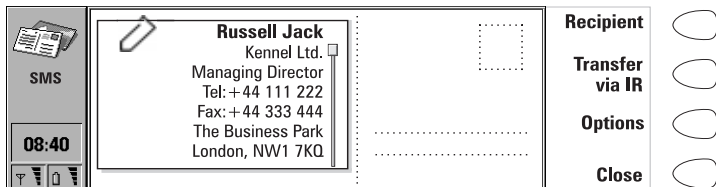

Figure 3

A business card is a special short message containing personal information about a contact, just like a normal business card. You can send your own business card or any contact card as a business card.

Business cards sent from a device that supports the Nokia 9110 Communicator contact card format can be saved directly as new contact cards in the Contacts directory. Just open the received business card and press **Create card**.

**Tip:** When you have received a business card, press **Reply** to send your own business card to the sender.

### To send a contact card as a business card

- 1 Open the Business cards folder.
- 2 Select a business card and press **Open**.
- 3 Press **Options** to define which fields to include in the business card. **Change** toggles the fields on or off.  
If you are sending the business card to a Nokia 9000 Communicator or a wireless phone, select *Compact*. This makes the business card to a compatible format. If you are sending the business card to another Nokia 9110 Communicator or a Nokia 9000i Communicator, select *Generic*.
- 4 Press **Recipient** to select a recipient for the business card. Or, if you want to send the business card to another communicator via the infrared link, press **Transfer via IR** (be sure to activate the Infrared activation application in the receiving communicator).
- 5 Press **Send**.

**Note:** Sending a business card with an attached picture makes the message very long and may be expensive.

## SMS settings

Press **Settings** in the SMS application main view to change the settings. The settings you define here are used until you change them again.

*Message centre settings* — In order to be able to send short messages, you must have stored the number of the message centre in this setting and selected which message centre you want to use in *Message centre in use*. You can add new or edit existing message centre numbers in *Message centres*.

**Note:** The message centre number may be included in some SIM cards. If you use several SIM cards in your communicator, make sure that this setting contains the appropriate message centre number.

*Reply via same centre: Yes / No* — This network service allows the recipient of your short message to reply using your short message centre. By setting this option to *Yes*, you allow the recipient to reply to your message, even if the recipient does not subscribe to the Short Message Service, provided that the recipient has the means to type a reply message.

*Validity period: 1 h / 6 h / 24 h / One week / Maximum* — If the recipient of a message cannot be reached within the set validity period, the message is removed from the message centre. If *Maximum* is chosen, the validity period is set to the maximum value allowed by the message centre. Note that the network must support this feature.

*Message conversion: None* (sent as a normal short message) / *Fax / X.400 / Paging / E-mail / ERMES / Speech* (message synthesised from a short message) — In order to receive a converted message, the recipient must have an appropriate device available, and the network must support this feature. For example, if you choose *Fax*, the recipient must have a telefax machine or similar device connected to the number.

*Request delivery report: Yes/No/Show immediately* — When this network service is set to *Yes*, the status of the sent message (*Delivered, Pending, Failed*) is shown in the Delivery reports folder. When set to *Show immediately*, you will receive a note when the message has been delivered to the recipient.

*Send long messages: Yes/No* — If set to *No*, messages that are longer than 160 characters are sent as several SMS messages. If set to *Yes*, messages that are longer than 160 characters are sent as several messages, but if the recipient



has a Nokia 9110 Communicator or a Nokia 9000i Communicator, the messages are received as one long message.

*Receive info messages: Yes/No/View index* — If your network supports this feature, it will send you information about various topics. If you choose *View index*, the network will send you a list of topics, and you can select those topics on which you wish to receive information.

*Info service mode: Display and save/ Display only/Save only* — If this is set to *Display and save*, messages are displayed and saved in the Info messages folder. If you select *Save only*, info messages are not displayed but saved in the folder. If you select *Display only*, messages are displayed but not saved.

*Info service language* — You can select in which languages you want to receive info messages. Select either *All*, or a maximum of four languages.

*Info service topics* — Message topics vary according to the operator. You can define here what type of messages you want to receive. For more information about the Info service, contact your service provider.



# 9. Internet

To obtain access to the Internet, the cellular network you use must support data calls; the data service must be activated for your SIM card; you must have obtained an Internet Access Point (IAP) from an Internet service provider; and you must have entered the proper Internet settings.

Your service provider will give you instructions on how to configure the Internet settings. Follow the instructions carefully.

**Tip:** With one Internet application active, you can quickly switch to another by pressing the Internet application button. In this way you do not have to make a new data call.

## To start an Internet application

- 1 Press the Internet application button on the communicator keyboard.
- 2 Select an application with the selection frame and press **Select**.
- 3 To close an application, press **Close**.
- 4 To disconnect from the Internet, press **Hang up**. The "Disconnecting" note will be shown on the display and the data call will end.

**Note:** Depending on the network configuration and load, establishing an Internet connection may take up to one minute or even longer.

## Internet applications

**Mail** — An electronic mail application which lets you send and receive e-mail all over the world using the Internet.

**World Wide Web (WWW)** — A hypertext-based system for finding and accessing resources on the Internet.

**Telnet** — Allows your communicator to connect to computers that provide terminal services through the Internet.

**Terminal** — Allows your communicator to connect to computers, such as mainframe computers, that provide direct dial-in terminal services. Both Telnet and Terminal emulate the VT100 terminal.

**Text Web** — Used for obtaining information from the Internet via SMS.

**Tip:** There is a glossary of Internet terms and abbreviations at the back of this manual.

## To set up your Internet access point

If you do not already have an internet access point (IAP) or you want a new one, this service provides you a convenient way to set up the internet connection.

Before being able to use the Internet services, you need to configure an Internet connection. You can subscribe to the Internet services of selected providers in your country directly with your Nokia 9110 Communicator, provided that the data service is activated for your SIM card. See the instructions below.

- 1 Open the WWW application.
- 2 Select the bookmark "Internet setup" and press **Go**.
- 3 Select your home country in the list with the arrow keys and press **Go**.
- 4 Confirm the operation by pressing **Accept**.
- 5 Select the hyperlink to the Internet service providers and press **Go**. You will be connected to the WWW site where you can select your preferred service provider. The connection is established via a data call.
- 6 When the connection has been made, follow the instructions on the display to select a service provider and to subscribe to their Internet services.

## Internet settings

Information concerning the settings must be obtained from your Internet service provider. The service provider may be able to configure the access point for you via a special SMS message, or a WWW page, which sets all the necessary Internet access settings.

To define the Internet settings manually, press **Settings** in the main view of the Internet application.

**Note:** The Internet settings apply to Mail, WWW and Telnet.

## To define an Internet access point

- 1 In the Internet settings main view choose *Internet access* and press **Change**.
- 2 To define a new Internet access point, press **New**. To modify or change an existing IAP, press **Edit**.

**Note:** The exact values of the settings are provided by your Internet service provider.

The Internet settings are:

*Modem initialisation* — Enables you to define the modem settings of your communicator:

*Autobauding* — The data transmission rate is determined automatically. Most networks support this option.

*Fixed 9600 b/s* — A fixed data transmission rate is used. If you have problems with making a data call, try this option.

*Fixed 14400 b/s* — Can be used if supported by the network. Do not use this option, unless you are sure your network supports it.

*Custom* — When a data call is established, the modem is initialised according to the string you enter here.

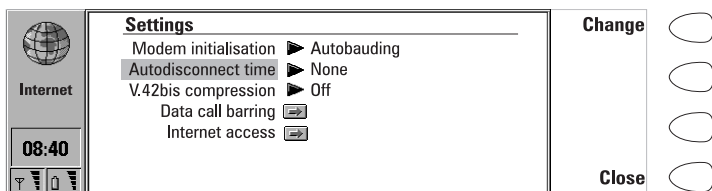

Figure 1

*Autodisconnect time: None/2/5/10 minutes* — The connection to the Internet will automatically close after the inactivity period defined here.

*V.42bis compression: On/Off* — Speeds up data transfer, e.g. sending or receiving mail, when supported by the cellular network. Set this to *Off*, unless you are sure your network supports this option.

*Data call barring* — You can restrict your data calls in the same way as your voice calls, see "Telephone settings" on page 63. To see the current barring mode, press **Get status**. To cancel all barrings, press **Cancel data barrings**.

*Internet access* — Lists the defined Internet access points. You can configure the communicator differently for each Internet access point. Press **Edit** to change the settings of an existing access point. Press **New** to define a new access point. Press **Delete** to remove an access point.

*Provider name* — The name of the Internet service provider. If you define the access point manually, the name can be edited freely.

*Phone number* — The telephone number of the Internet access point.

*User name* — Enter your user name if required by the Internet service provider. The user name may be needed in the PPP authentication process.

*Prompt password: Yes/No* — If you must enter a new password every time you log on to a server, or you do not want to save your password, set this to *Yes*.

*Password* — Enter your password if required by the Internet service provider. The password may be needed in the PPP authentication process.

*Advanced settings* — Opens a new set of options with which you can further adjust the Internet access point, if required:

*Modem initialisation* — Enter any modem initialisation string containing AT commands here, if needed. This initialisation string is executed after the initialisation string you define in the *Modem initialisation: Custom* option of the Internet settings.

*Login customisation: None/Manual* — Some Internet access points do not automatically enable PPP. In such cases you need to choose either *Manual*, as it allows you to enter your login name and password manually in a terminal connection, or press **New** in the pop-up box, to write and save a new login script.

If you choose *None*, your password and user name are automatically taken from the Internet access point settings.

For more information on login scripts, see the *scripts.txt* file on the diskette supplied with the communicator.

*PPP compression: On/Off* — Speeds up data transfer when supported by the remote PPP server. If you have problems with establishing a connection, try setting this to *Off*.

*IP address* — The IP address of the communicator.

*Default gateway* — The IP address of the system that is a gateway out of the local network.

*Network mask* — Shows which portion of the IP address of the communicator identifies the network.

*Primary nameserver* — The IP address of the primary nameserver.

*Secondary nameserver* — The IP address of the secondary nameserver.

**Tip:** Some Internet service providers refer to these nameservers as DNS1 and DNS2.

# Mail

The Nokia 9110 Communicator mail system is compliant with the Internet standards SMTP, IMAP4, POP3, MIME1 and MIME2.

Mail is started in the Internet main view by selecting Mail and pressing the **Select** command button. The Mail main view shows the following folders:

**Own texts** — Contains the documents you have written with the communicator. The documents may contain formatted text, but the text will appear in the editor without formatting.

**Received mail** — Contains mail fetched from the Remote mailbox. See "To fetch mail" on page 92.

**Document outbox** — The outgoing communications manager of the communicator.

**Remote mailbox** — Your electronic mailbox service which receives all your mail. This service may be offered by a network operator, your company, or an Internet service provider. The required mailbox and Internet access point settings are described in "Mail settings" on page 87.

## Mail settings

Be sure to define your Internet access point as described in "Internet settings" on page 84.

### To define the mail settings

- 1 Press **Settings** in the Mail main view.
- 2 Select the item you want to change, and press **Change**.

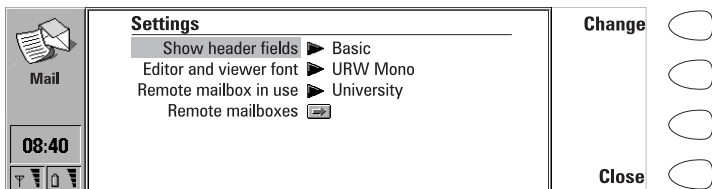

Figure 2

**Show header fields** — The term header field refers to the information given at the top of an e-mail message. This setting controls which header fields within the received message will be shown when the message is opened:

**None** — Shows no header fields, although the sender and the subject of the message are still shown in the name of the message.

**Basic** — Shows the *Date*, *From*, *To* and *Subject* fields.

**All** — Shows all possible fields.

*Editor and viewer font: URW Mono / URW Roman / URW Sans* — Determines the font used in the mail editor and viewer.

*Remote mailbox in use* — Determines the mailbox to which the connection is made.

*Remote mailboxes* — Press **Change** to open the Remote mailboxes view, where you can add new mailboxes, and edit and remove existing ones. When you press **New** or **Edit** in the Remote mailboxes view, the following options become available:

*Remote mailbox name* — Enter the name of the remote mailbox. The name can be entered freely.

*Internet access* — Select which Internet access point you want to use for connecting to this mailbox.

*Sending settings* — Press **Change** to define the settings of the mail messages you send from this mailbox. The settings are:

*Own mail address* — You must enter the e-mail address given to you by your Internet service provider. The address must contain the @ character. Replies to your messages will be sent to this address.

**Note:** E-mail addresses cannot contain accented characters, such as é or ä.

*Sending host* — The IP address or host name of the computer that sends your Internet mail.

*Send mail: Immediately / Upon request / During next connection* — Choose *Immediately* to send mail automatically; *Upon request* if you want to write several mail messages and send them at your convenience; or *During next connection* if you want your mail sent the next time you make a connection to the Internet access point that your mailbox uses. See "To send mail" on page 90.

*Copy to own mail address: Yes / No* — If set to Yes, a copy of the mail will be automatically sent to the address defined in *Own mail address*.

*MIME character encoding: On / Off* — Allows another MIME-compliant mail system to read the character set used in your communicator. Only when text containing special characters, e.g. á, à, ß, is sent to a non-MIME-compliant mail system, should the MIME character encoding be turned off. When the MIME character encoding is off, special characters are automatically converted to ASCII characters: á becomes a and so on.

*Signature file* — Allows you to add your signature to the mail message. The signature file must first be stored as a text file in the Own texts folder, where it is then selected.



*Receiving settings* — Press **Change** to define the settings of the mail messages you receive to this mailbox. Your remote mailbox service provider will supply you with the required information. The settings are:

*User name and Password* — These may be required to connect to the server and to open your mailbox.

The password characters appear as asterisks (\*) on the display. The user name and password stored here will automatically be offered to the server. If you enter your user name and password incorrectly, you will be prompted to enter them again when you connect to the Remote mailbox. If you enter your user name and password incorrectly three times, the connection to the Remote mailbox will end. For information on how to change the password, contact your remote mailbox service provider.

*Receiving host* — The IP address or host name of the computer that receives your e-mail.

*Folder* — *INBOX* is the default folder for your incoming mail. Do not change this setting without consulting your remote mailbox service provider. This setting is only available when the mail protocol is IMAP4.

*Protocol: IMAP4 / POP3* — Choose the mail protocol your remote mailbox service provider recommends.

*Fetch headers: All / Recent* — Determines whether all mail or just the mail received since the last connection will be shown in the Remote mailbox. It is possible to have old or unread mail in the Remote mailbox.

*Fetch attachments: Yes / No* — Determines whether possible mail attachments are fetched or not. This option is only available if the mail protocol is IMAP4. Note that text attachments are always fetched.

*Delete fetched: Yes / No* — Determines whether fetched mail will be automatically removed from the Remote mailbox. All fetched mail goes to the Received mail folder.

*Timed fetching settings* — With this setting you can set your communicator to fetch mail automatically.

*Timed fetching: On/Off* — Determines whether the timed fetching function is in use or not.

*Start at: Date and Time* — You can specify the date and time when the communicator starts to fetch your mail. Use the date and time formats specified in the System settings.

*Time limit: None/5/10/30/60 min* — You can set the time limit for the fetching operation. This way your communicator will not fetch too large messages, which would take too much time.

*Frequency: None/ Daily/ Weekly/ Working days/ Every other week/ Monthly*— Determines how often mail is fetched.

*Size limit: None/5/10/50/100/250 kB*— You can set the size limit for the mail to be fetched. This way your communicator will not fetch too large messages, which would take too much time and occupy too much memory.

## To send mail

### To write new mail

- 1 Press **Write mail** in the Mail main view. An empty mail editor opens.
- 2 Write the message. You can change the font within the Mail settings.
- 3 When the message is ready to be sent, press **Recipient**. The Mail directory opens.

### To send previously written documents

- 1 Select the Own texts folder in the Mail main view and press **Open**.
- 2 Select a document and press **Open**. If the document contains text formattings, you will be asked if you want to edit the original and lose all formattings, or create a copy in the Own texts folder and edit the copy instead.
- 3 When the document is ready to be sent, press **Recipient** to open the Mail directory.

### To select a recipient

There are two ways to select a recipient for your mail message:

- 1 Select the contact(s) in the Mail directory with the selection frame and press **Select**. If a contact has several mail addresses, a pop-up box opens, listing the available mail addresses. Select an address and press **Select**. Or,
- 2 Enter the recipient's address manually by pressing **Enter** **address**. Remember that the mail address must contain the @ character, and that the address cannot contain accented characters.

The Mail envelope opens whenever you are about to send mail, see figure 3. All the field entries are editable.

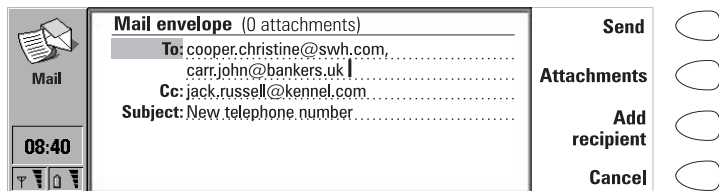

Figure 3

## To add addresses to the To or Cc fields of the Mail envelope

- 1 Select whether to add a new recipient to the *To* or the *Cc* field by scrolling to the appropriate field.
- 2 Press **Add recipient**.
- 3 Select the recipients as described above.

**Note:** Multiple addresses in the *To* and *Cc* fields must be separated by a comma.

## To determine how the current mail message will be sent

Press the Menu button in the mail envelope and select *Send options*. To change a setting, press **Change**. The possible options are:

*Send mail: Immediately/ Upon request/ During next connection*

*Copy to own mail address: Yes / No*

*MIME character encoding: On/ Off*

For more information, see "Mail settings" on page 87.

## To send mail upon request

When you have several mail messages to send, you may want to use the *Upon request* option. This way you may send all your mail during the same data call.

- 1 Write your mail, select the recipient, press the Menu button and select *Send options*.
- 2 Select the *Send mail: Upon request* option and then press **Send** to send the mail.
- 3 Go to the Document outbox and press **Open**.
- 4 Press **Start** to send your mail.

You can also select the *During next connection* option, with which your mail will be sent automatically the next time you make a connection to the Internet access point your Remote mailbox uses.

## To add attachments to the message

- 1 Press **Attachments**.
- 2 A list of attachments opens. To add documents to the list, press **Add**.
- 3 Select the document(s) from the Own texts and Downloaded files folders and press **Select**.
- 4 When all the desired attachments are in the list, press **Close**.
- 5 To send the message, press **Send**.

## To fetch mail

E-mail addressed to you is not automatically received by your communicator, but by a Remote mailbox, see figure 4. This is to let you determine which messages you want to read and when. To read your mail, you must first connect to your Remote mailbox and then select the messages you wish to fetch onto your communicator. Connection to the Remote mailbox is established via a data call.

If your Remote mailbox server is capable of sending you special short messages, you will hear a tone - unless the system is set to a silent profile - and see a note when new mail arrives in your Remote mailbox. The message may also contain information about the mail message, in which case you can either fetch or remove the mail by pressing **Fetch** or **Delete** in this SMS message.

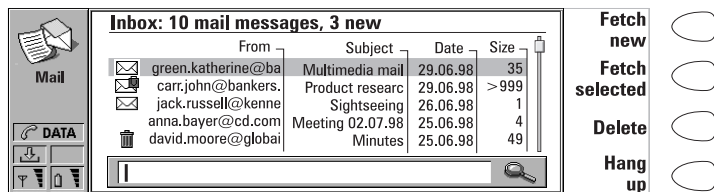

Figure 4

### To connect to the Remote mailbox

The Mail and Internet access point settings must be configured correctly. Read "Mail settings" on page 87, and follow the instructions given by your Remote mailbox and Internet service providers.

- 1 Move the selection frame in the Mail main view over the Remote mailbox and press **Connect**.

Unread messages in the Remote mailbox are marked with ✉, unread messages with attachments with ✉📎 and deleted messages with 🗑️.

### To fetch all new mail

- 1 Once you have connected to the Remote mailbox, press **Fetch new**.
- 2 All mail with the ✉ icon is fetched to the Received mail folder.
- 3 After all new mail has been fetched, connection to the Remote mailbox is closed and the Received mail folder opens.

### To fetch a selected message

- 1 Select the mail message(s) you want to fetch and press **Fetch selected**.
- 2 After the mail has been fetched, the Remote mailbox view returns.

### To remove a mail message

- 1 Set the *Delete fetched* setting to *Yes* in the Mail settings. All fetched messages are removed from the Remote mailbox. Or,
- 2 Select the message(s) you want to remove with the selection frame, and press **Delete**. If you want to cancel the removing, press **Undelete**.

The messages will be removed when you exit the Remote mailbox. However, all fetched messages will be retained in the Received mail folder.

### To use the Menu button

If you press the Menu button in the Remote mailbox, the following options become available:

*Change folder* — Opens another mail folder.

*Create folder* — Creates a new folder.

*Copy* — Copies the selected mail message(s) to another folder.

*Move* — Moves the selected mail message(s) to another folder.

*Remove folder* — Removes the selected folder and its contents and subfolders.

*Rename folder* — Gives the folder a new name.

*Off-line* — Ends the data call.

*On-line* — Re-establishes the data call.

### To disconnect from the Remote mailbox

- 1 Press **Hang up**.
- 2 If you have messages marked as deleted, you will be prompted to confirm the deletion.
- 3 The connection to the Remote mailbox closes, and the Mail application main view returns to the display. If you have fetched messages, the Received mail folder opens on the display.

## To read mail

Mail that you fetch from your Remote mailbox is stored in the Received mail folder.

### To read a mail message

- 1 Select the Received mail folder in the Mail main view and press **Open**. Mail messages that have not yet been opened in the communicator are marked with .
- 2 Select the message, and press **Open**.

When you open a received mail, the following commands become available:

**Attachments** — Lists all MIME attachments: text, image, audio, video or application. If the message does not contain any attachments, this command

is dimmed. When viewing the list of attachments, you may select an attachment and choose from the following options:

**View** — Opens the attachment if there is enough memory and if the message can be opened in the communicator.

**Save** — Saves the attachment in the Downloaded files folder.

**Close** — Returns you to the previous screen.

**Delete** — Removes the open mail message.

**Close** — Returns you to the Received mail folder.



Figure 5

## To use the Menu button

If you press the Menu button in an opened mail message, the following options become available:

**Reply (include text)** — Replies to a mail message and includes the received mail in your reply. If the received mail message is a MIME document, only the first text part is copied to the message and may be edited. Attachments cannot be included in the reply message

**Reply** — Replies to a mail message without including the received mail in your reply.

**Reply all (include text)** — Replies to all the persons who received the mail and includes the received mail in your reply.

**Reply all** — Replies to all the persons who received the mail without including the received mail in your reply.

**Forward** — Forwards the received mail and the possible mail attachments.

**Find URL** — This option searches for a URL address in the message. If there is a URL, you can open a connection to the selected address by pressing **Fetch**.

**Hierarchical structure** — Shows the hierarchical structure of the mail message.

**Print** — Prints the message.

Scroll to any of these and press **Select**.

## World Wide Web

The Nokia 9110 Communicator supports HTML 3.2, with the exception of some features. SSL, the security protocol, is also supported. See "Glossary" on page 175. The WWW browser does not support Java or Java script.

To connect to the World Wide Web, the Internet service must be activated for your SIM card, and you need an account with an Internet service provider.

To open the World Wide Web application, select WWW in the Internet main view, and press **Select**.

To exit the WWW, press **Close** or **Hang up** in the Bookmarks list, which is the main view of the application. This ends the data call and closes the WWW application.

For information on how to create tailored WWW pages for the Nokia 9110 Communicator, see the documents on the CD-ROM.

## WWW settings

To change the WWW settings:

- 1 Open the WWW application and press the Menu button.
- 2 Select *Settings*.
- 3 To change a setting, select it and press **Change**.

The WWW settings are:

*Autoload images: Yes / No* — If set to *Yes*, the communicator automatically fetches the inline JPG or GIF images on a WWW page. When set to *No*, WWW pages are fetched without images and shown much faster.

*Clear cache on exit: Yes / No* — Most recently fetched WWW pages are kept in the temporary memory of the communicator, the "cache". If set to *Yes*, the cache, history list and cookie file are automatically emptied after you close the WWW application. If set to *No*, the cache stores as much information as possible. When you restart the WWW application, the most recently stored information is fetched from the cache without making a new data call.

*Accept all cookies: Yes / No* — Determines whether the cookies functionality is enabled. See "Glossary" on page 175.

*Default access point* — Defines the Internet access point used as a default in the WWW application.

*Proxies* — To change the proxy settings, press **Change**.

*Internet access point* — You can select an IAP to be used for this particular WWW page.

*HTTP proxy* — The hostname of the HTTP proxy server used with the selected IAP.

*HTTP proxy port* — The proxy port of the proxy server.

*Security proxy*— The proxy that is used with SSL secure connections.

*Security proxy port*— The security proxy port of the proxy server.

*No proxy for*— You may define domains for which the HTTP proxy is not needed. Domain names are separated with commas, for example nokia.com, edu.fi. You may specify the domains as accurately as you wish.

## Bookmarks

The WWW main view shows the Bookmarks list. When you select a bookmark from the list, the name of the Internet access point used for connecting to the bookmark is shown on the top right corner. The date when the bookmark was last fetched is shown beside the name of the bookmark. See figure 6.

Below the Bookmarks list is the address field where you can enter the URL address of the WWW page you want to fetch. If you select a bookmark from the list, the address field shows the URL address of the bookmark.

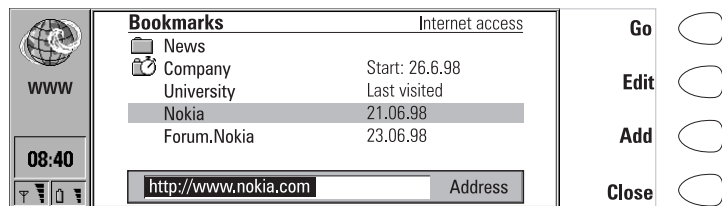

Figure 6

### To fetch a WWW page

- 1 Select an entry in the Bookmarks list or enter a URL in the address field.
- 2 Press **Go**.

**Tip:** To fetch WWW pages stored in the Own texts or Downloaded files folders of the communicator or the memory card, use the prefix "file:///" (note: three slashes) instead of "http://".

### To add a new bookmark

- 1 Press **Add**, or if you want to modify an existing bookmark, press **Edit**.
- 2 Enter the name you want for the bookmark in the *Name* field.
- 3 Enter the URL address of the bookmark, e.g. www.nokia.com, in the *Address* field.



## To set advanced bookmark properties

Select *Details* and press **Change**. The advanced settings are:

*User name* — If a user name is needed to fetch the bookmark, enter your user name here.

*Password* — If a password is needed to fetch the bookmark, enter your password here.

*Internet access selection: Automatic/Manual* — If you select *Automatic*, the current or the default IAP is used for this bookmark. If you set this to *Manual*, only the IAP defined in the following setting is used.

*Internet access* — This setting is available only if the previous setting is set to *Manual*. You can select which IAP to use for the bookmark.

## To fetch items with a page already open

You can fetch a WWW page even if you have a page already open:

- 1 Press the Menu button and select *Bookmarks*. A simplified form of the Bookmarks list opens.
- 2 Select an entry in the Bookmarks list or enter the URL in the address field.
- 3 Press **Go**.

To close the Bookmarks list, press **Close**.

## To use the Menu button

If you press the Menu button in the Bookmarks list, the following options become available:

*History* — Contains a list of browsed documents. To fetch a page from the list, select the page and press **Go**. To empty the history list and the cache, press **Clear history**.

*Find* — You can search for names and addresses in the Bookmarks list.

*Open file* — You can open files from the Own texts and Downloaded files folders.

*Move* — You can move the selected bookmark from one folder to another.

*Delete* — Removes the selected bookmark or bookmark folder.

*Create folder* — Creates a new bookmark folder.

*Import bookmarks* — Imports a bookmark file from the Own texts or Downloaded files folder to the Bookmarks list.

*Export bookmarks* — Converts the bookmark file to the HTML format and saves it to the Own texts folder.

*Clear cache* — Empties all caches and temporary files.

*Settings* — Opens the WWW settings. See "WWW settings" on page 95.

## To make a smart bookmark

A smart bookmark contains a WWW page which your communicator fetches at certain time. These WWW pages can only consist of text or images, and they cannot be SSL secure.

- 1 Create a new bookmark folder by pressing the Menu button and selecting *Create folder*.
- 2 When the new folder is ready, press **Edit**. The following options become available:

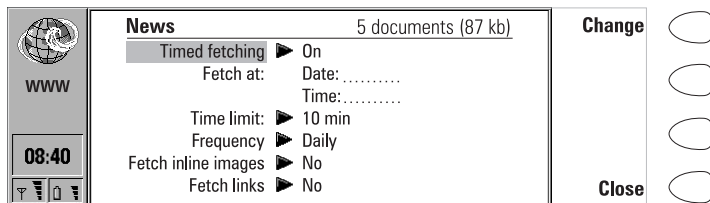

Figure 7

*Timed fetching: On/Off* – When this is set to *On*, a clock symbol appears in the folder, and the WWW pages in the folder are fetched according to the settings defined below.

*Fetch at* – You can define the time and date when the pages are fetched. The date and time formats are set in the System settings.

*Time limit: None/5/10/30/60 min* – You can set a time limit for the fetching process. This way the data call will not last too long and thus become very expensive.

*Frequency: None/Daily/Weekly/Working days/Every other week/Monthly* – This setting enables frequent fetching of the WWW pages.

*Fetch inline images: Yes/No* – You can decide whether the inline images in the WWW pages are fetched.

*Fetch links: Yes/No* – If set to *Yes*, all links to other texts and images in the defined WWW pages are fetched. If set to *No*, only the WWW pages are fetched.

- 3 Press **Close**.
- 4 Select the page(s) you want to fetch with the selection frame and press the Menu button.
- 5 Select *Move* and then choose the folder which you just created. The bookmark(s) will be moved to that folder.

Pages fetched with the smart bookmarks function are stored in a folder cache. To empty the cache, press the Menu button in the smart bookmarks view and

select *Empty folder cache*. If you select *Go*, all the items in the folder are fetched in the folder cache.

**Note:** SSL secure WWW pages are never stored in the cache.

## To navigate in WWW

- 1 Select a bookmark in the Bookmarks list or enter a URL address into the address field and press **Go**.
- 2 If the WWW page was already recently fetched, the page is fetched from the cache. If not, the page is fetched from the Internet by making a data call to the selected Internet access point.
- 3 Some servers have access restrictions that require a valid user name and password. In this case, you will be asked to enter the user name and password before the WWW page can be fetched. The communicator stores the passwords and user names that you enter to gain access to that domain, and the next time you connect to the same domain, they will be offered automatically.

**Note:** Stored passwords to individual web sites are removed when the communicator is rebooted or the cache emptied.

- 4 When the WWW page is being fetched, the line on top of the display shows the status of the connection, the title of the page, and how many bytes of the page have been received.

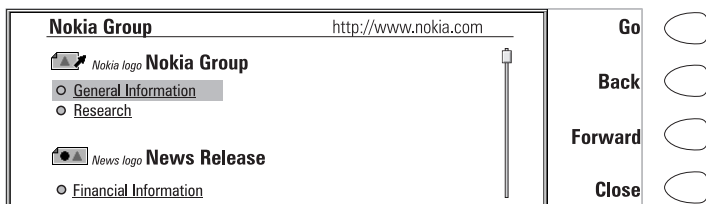

Figure 8

When the page is on the display, use the arrow keys to scroll the view and to choose hyperlinks and hotspots. Each arrow key press selects the nearest hyperlink or hotspot, or moves the view one line up or down. See figure 8.

**Tip:** To select the next or previous hyperlink on the WWW page, press the Tab key or Shift + Tab, respectively.

## To use the navigation commands

After the WWW page has been fetched, the following commands become available:

**Go** — If there is a link to another WWW page in the currently open page, select the link with the selection frame and press **Go** to fetch the page. If the selected item is a button for sending or resetting a form, **Go** either sends the form or resets it to default values.

**Get image** — If the selected item is an inline image icon, the first command changes to **Get image** with which you can fetch the image. If the image is of an unsupported format, the image icon looks broken on the display and cannot be selected.

**Change** — If the selected item is a selection list, check box or radio button, the first command is **Change**. With **Change**, you can tick the box or button on and off.

If you have a form open, **Change** allows you to attach a file to it. You can select the attachment from the Own texts, Received messages/mail and Downloaded files folders. Press **Open** to open the folder, choose the desired file and press **Select**.

**Back** — If you have browsed through at least two WWW pages, **Back** allows you to fetch the previous page

**Forward** — If you have browsed through at least two WWW pages, and viewed the previous page with the **Back** command, you can fetch the next page by pressing **Forward**.

**Close** — Returns to the Bookmarks list.

**Cancel** — Interrupts the fetch operation.

**Tip:** You can copy text on the WWW page by pressing Ctrl-C. You can then for example open the Notes application, open a new document and paste the copied text into the document by pressing Ctrl-V. You can also print the copied text in the Notes application.

## To use the Menu button

When you have a WWW page open and you press the Menu button, the following options become available:

**Add bookmark** — Adds the current address to the Bookmarks list.

**History** — Contains a list of browsed documents.

**Find** — You can search for various items, such as words in the WWW page.

**Open file** — You can open files from the Own texts and Downloaded files folders.

**Bookmarks**—Opens the Bookmarks list where you can select a new page to be fetched.

**Go off-line**—Ends the data call.

**Reload**—Reloads the current WWW page from the network.

**Tip:** You can also reload a WWW page by pressing Ctrl-R.

**Activate automatic update (Ctrl-U)**—With this option the opened WWW page updates itself continuously in every 10, 30 or 60 seconds. This is very convenient for example when browsing stock exchange WWW pages.

**Note:** The continuous updating disables the *Autodisconnect time* function. Therefore, the data call does not go off-line, which may make the call expensive.

**Disable automatic update (Ctrl-U)**—Stops the continuous updating of the WWW page.

**Save**—Saves the page contents or the image to the Downloaded files folder, or adds the address of the page to the Bookmarks list.

**Clear cache**—Empties all caches and temporary files.

**Settings**—Opens the WWW settings. See “WWW settings” on page 95.

## To view images

Images that are part of the fetched WWW page are called inline images. By default, inline images are not fetched with the WWW page, but will be displayed as icons, unless the option *Autoload images* is set to **Yes** in the WWW settings. To fetch an image, select the image icon and press **Get image**. The communicator is capable of fetching images that are in JPG or GIF format.

Inline images can also be image maps. An inline image map acts like a hyperlink. A fetched image map contains a cursor that can be moved with the arrow keys. When you press **Go**, the pixel coordinates of the cursor are sent to the server, and the corresponding WWW page is fetched.

Images that are separate documents and not part of a hypertext document are called external images. When an external image is fetched, it is viewed separately from the hypertext document in the image viewer. The commands in the external image viewer are the same as in the fax viewer.

## To download add-on software

The WWW application can be used to install applications and plug-ins on your communicator. If you install plug-ins, the WWW application activates them when necessary.

- 1 Go to the WWW page where the add-on software package exists.
- 2 Select the hyperlink that points to the software package.
- 3 Press **Go** to fetch the package. After the software package has been successfully fetched, the software installation view opens.

Press **Install**. If there is sufficient memory available, the software will be installed.

**Caution:** Beware of viruses. Only install on the communicator software you have obtained from sources that offer adequate protection against viruses.

## Terminal

The Terminal application is started in the Internet main view by selecting Terminal and pressing **Select**. The Terminal application is used to connect directly, not via the Internet, to a remote computer by way of a data call.

The Terminal main view shows the defined Terminal connections. The Terminal application is similar to the Telnet application, in that both of them emulate the VT100 terminal display. See figure 10.

To connect with a pre-defined Terminal connection, select the connection and press **Connect**.

To create new or edit existing connections, press **Define**.

To change the settings for incoming data calls, press **Settings**, select the setting and press **Change**. The available settings are:

*Local echo for incoming data call* — If set to *On*, characters typed from the communicator keyboard are echoed locally to the communicator. If set to *Off*, they are echoed to the remote host computer.

*Line end for incoming data call* — Defines which character is generated with the Enter key in incoming data. The alternatives are: Carriage return (*CR*), Linefeed (*LF*), and Carriage return - Linefeed (*CR/LF*)

## To define Terminal connections

After you have pressed **Define** in the Terminal main view, the defined Terminal connections are shown.

To remove the selected connection, press **Delete**.

To edit existing connections, press **Edit**, or press **New** to define new Terminal connections. The following settings become available:

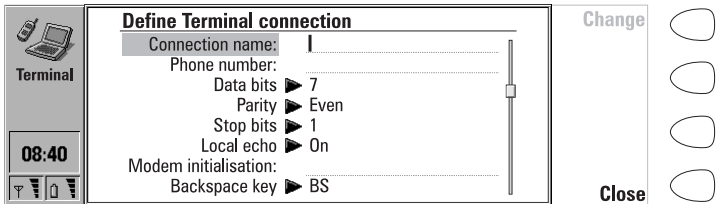

Figure 9

*Connection name* — Write the name of the connection. The name can be defined freely.

*Phone number* — The phone number for accessing the service. The phone number may include spaces and hyphens.

*Data bits: 7/8* — Service/host-specific communication parameter.

*Parity: None/Odd/Even* — Service/host-specific communication parameter.

*Stop bits: 1/2* — Service/host-specific communication parameter.

*Local echo: On/Off* — If set to *On*, characters typed from the communicator keyboard are echoed locally to the communicator. If set to *Off*, they are echoed to the remote host computer.

*Modem initialisation* — Enter here a modem initialisation string containing AT commands, if needed. This initialisation string is executed after the string you define in the *Modem initialisation: Custom* option of the Internet settings.

*Backspace key: BS/DEL* — Defines whether the keyboard backspace key is used as a backspace or delete key.

*Line end* — Defines which character is generated with the Enter key in the terminal session. The alternatives are: Carriage return (*CR*), Linefeed (*LF*), and Carriage return - Linefeed (*CR/LF*).

## Terminal connection

When you have connected to the remote system, the following commands become available:

Press **Keys** to emulate the VT100 special keys, which are not available on the communicator keyboard. The special keys include:

Four function keys: PF1-4. The specific function of these keys depends on the service or program to which you are connected.

All VT100 application keypad keys: numbers 1-9, hyphen, comma, period, enter.

The following VT100 functions: reset terminal, Ctrl-\, Ctrl-], Ctrl-~, Ctrl-?.

The selected special character is entered to the left of the cursor by pressing **Insert**.

The arrow keys can be used for scrolling the view. Scrolling does not affect the cursor position. Pressing any keyboard key returns the view to the cursor position.

Press **Hang up** to close the connection to the host, end the data call and return to the Terminal main view.

## To transfer text

The purpose of the text transfer function is to enable you to send text from the communicator to the host computer, or to copy text from the host computer to the communicator. This function can be used, for example, to send pre-written mail messages to the company mainframe computer, or alternatively, copy received mail and then read it later, off line.

## To send text to the host computer

- 1 Press **Send text**.
- 2 Open one of the folders shown and select the document you want to send.
- 3 Press **Send**. If you want to stop the sending procedure, press **Stop sending**.

While the text is being sent, the keyboard is inactive.

## To copy text from the host computer

- 1 Prepare the text reading application on the host.
- 2 Press **Capture text**. All interaction with the host will be recorded in a file in the Downloaded files folder. Control characters, except line changes, will not be stored.

Press **Stop capture** to end the text capture process.



# Telnet

The Telnet application is similar to the Terminal application, in that both of them emulate the VT100 terminal display. See figure 10.

**Note:** The Telnet application can be installed to your communicator from the CD-ROM included in the sales package.

Once a Telnet connection is established, you must in most cases enter your login name and a password in order to be able to use the services provided by the host computer. The Telnet main view shows all pre-defined Telnet hosts.

To connect to a pre-defined Telnet host, select the host and press **Connect**.

To create new or edit existing connections, press **Define**.

## To define Telnet connections

After you have pressed **Define** in the Telnet main view, the defined Telnet connections are shown.

To remove the selected connection, press **Delete**.

To edit existing connections, press **Edit**, and to define new Telnet connections, press **New**. The following settings become available:

*Connection name* — Write the name of the connection. The name can be defined freely.

*Destination host* — Enter the connection address. The host is identified by either a numeric IP address or a textual host name. If required, place the name of the destination TCP port after the IP address, separated by a colon (:).

*Internet access points* — Select an Internet access point from those currently defined. To change the IAP, press **Change** and select a new IAP from the list.

*Backspace key: BS/DEL* — Defines whether the keyboard backspace key is used as a backspace (*BS*) or delete (*DEL*) key.

## Telnet connection

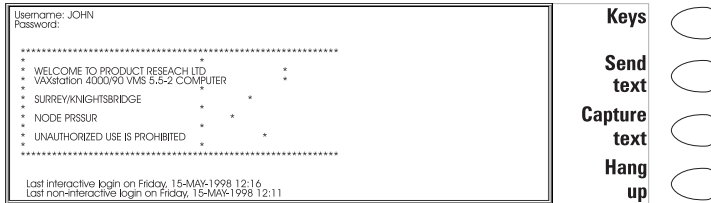

Figure 10

When you have connected to the remote system, press **Keys** to emulate the VT100 special keys, which are not available on the communicator keyboard. The special keys include:

Four function keys: PF1-4. The specific function of these keys depends on the service or program to which you are connected.

All VT100 application keypad keys: numbers 1-9, hyphen, comma, period, Enter.

The following VT100 functions: reset terminal, Ctrl-\, Ctrl-], Ctrl-~, Ctrl-?.

In a Telnet connection, these special keys include the following commands that can be used in the remote systems that support them:

*Interrupt* — Interrupts the current process on the remote computer.

*Skip command output* — Prevents the commands from being shown on the display.

*Are you there?* — Enquires whether the remote system is still running, if the execution of a task seems to take too long.

Select a special character and press **Insert**. The inserted special character sends a control signal to the remote computer; it is not shown on the display.

The arrow keys can be used for scrolling the view. Scrolling does not affect the cursor position. Pressing any keyboard key returns the view to the cursor position.

Press **Hang up** to close the connection to the host, end the data call and return to the Telnet application main view.

**Note:** The text transfer function is also available in Telnet. See "To transfer text" on page 104.

## Text Web

With Text Web you can fetch information from the Internet, using SMS. Such information can include for example flight schedules, weather reports and stock news. You can also access services provided by your network operator and Nokia.

### Nokia services

The contents are maintained by Nokia, and they cannot be changed. Nokia updates the contents from time to time.

### Operator services

The Operator services allows the network operator to provide various services to the subscribers. The operator-specific items may vary from subscriber to subscriber, and can be updated by the network operator.

### To define services

- 1 To define new service access points, press **Settings** in the Text Web main view.
- 2 Press **New** to open an empty service information card, or press **Edit** to modify an existing service. Enter the title of the service, the server number, which is a message centre number, and the service number, which is a phone number.

### To fetch information

- 1 In the Text Web main view, scroll to one of the service access points that you have defined and press **Select**.
- 2 Enter in the space provided a keyword that describes the type of information you are looking for. If you press **Get keywords**, you will receive a list of available keywords. **History list** contains keywords that you have used previously.
- 3 To send the keyword, press **Send**. When you receive a reply from the service provider, the TTML browser opens up.

### To use the browser

Press the arrow keys on the keyboard to move from one hotspot to another.

To follow a hyperlink, press **Fetch**. With **Change** you can tick off boxes and buttons.

To add the form to the Saved forms list, press **Save** and select *Save form*. To copy the text to the Downloaded files folder, select *Copy text*.

To send the form, press **Send**.









 <b>Text Web</b>  <b>08:40</b>   	<b>Quiz of the Day</b> <hr/> <u>An adult ostrich weighs</u> <input checked="" type="radio"/> 100 kg <input type="radio"/> 150 kg <input type="radio"/> 200 kg Name: ..... <input checked="" type="checkbox"/> Information may be used for advertising	<b>Change</b>   <b>Send</b>   <b>Save</b>   <b>Close</b> 
---	---	---

Figure 11

## Saved forms

Saved forms is a "hotlist" to which you can add items from the other services. It grants you quick access to Internet services.

To open the selected form, press **Open**. The TTML browser opens up with the same commands as above.

To rename a service, press **Rename** in the Saved forms main view. To remove the selected form, press **Delete**.

# 10. Notes

Notes is used for writing texts and managing various documents stored on the communicator.

**Note:** When you open a document, the document is opened in the appropriate editor or viewer. The available commands vary according to the editor/viewer.

Folders in the Notes main view are:

Own texts – Written mail, faxes, short messages, notes and memos

Received faxes/ messages/ mail – All received documents

Downloaded files – Documents downloaded with the Internet applications

Document outbox – Documents waiting to be sent

If you have a memory card inserted in the communicator, the memory card icon will be shown at the bottom of the folders list. See figure 1.

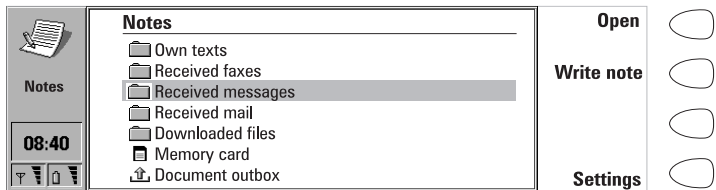

Figure 1

## To write a document

- 1 Press **Write note**. The note editor opens.
- 2 Write the document.

## To read a document

- 1 Select a folder and press **Open**.
- 2 Select a document from the list and press **Open**.

**Note:** If the opened document is very large, i.e. dozens of pages long, the time required before the document opens, is longer than with smaller documents.

### To print a document

- 1 Open the document.
- 2 Press the Menu button and select *Print*.

For more information, see "Document features" on page 34.

### To remove a document

- 1 Select a folder and press **Open**.
- 2 Select a document from the list and press **Delete**.

### To make a subfolder

- 1 Select a folder and press **Open**.
- 2 Press the Menu button and select *Create folder*.
- 3 Write down the name of the folder and press **OK**.

### To remove a subfolder

- 1 Select the folder under which the subfolder is located and press **Open**.
- 2 Select the subfolder and press **Delete**.

**Note:** Calendar memos and Contact images are permanent subfolders and thus cannot be removed.

### To use the Menu button

When you press the Menu button in an opened folder, the following options become available:

*Rename* — You can give a new name to the selected subfolder or document. Permanent folders cannot be renamed.

*Copy* — You can choose a folder into which the selected document will be copied.

*Move* — You can choose a folder into which the selected document will be moved.

*Create folder* — You can make a new subfolder.

*Copy to sounds* — You can add the selected tune to the list of ringing tones.

*Transfer via IR* — You can copy files to another Nokia 9110 Communicator via the infrared link. The IR port of the receiving device must be activated before the operation. See "Infrared activation" on page 129.

## To edit documents

For information about the available editing shortcuts see "Document features" on page 34.

Documents that open in the Notes editor can be directly edited and formatted. To format the text, press **Style**. Choose from the following options:

*Font: URW Mono / URW Roman / URW Sans* (true type fonts)

*Size: 10 / 12 / 14 / 18 / 24 / 36 / User defined* (measured in points)

*Bold (Ctrl-B): On / Off*

*Italics (Ctrl-I): On / Off*

*Underlined (Ctrl-U): On / Off*

*Justification: Left / Centred / Right / Full*

**Margins**— Opens a new view where you can choose a value for the top, bottom, left and right margins. The unit of measurement is either inches or centimetres, chosen in the System settings, see "System settings" on page 123.

A new style setting affects all new text from the cursor point forward. The margin settings, however, apply to the whole document. If you wish to change the settings permanently, do it in the main view settings, see "Notes settings" on page 113.

## Special characters

The special character key, Chr, on the communicator keyboard is used to create characters that are not included on the keyboard. The character key can always be used when you are able to enter characters from the keyboard.

### To insert special characters from the character table

- 1 Press and release the Chr key. The character table opens on the display, see figure 2.
- 2 Move the selection frame over the desired character with the arrow keys.
- 3 Press **Insert** to close the character table and to insert the selected character to the left of the cursor.

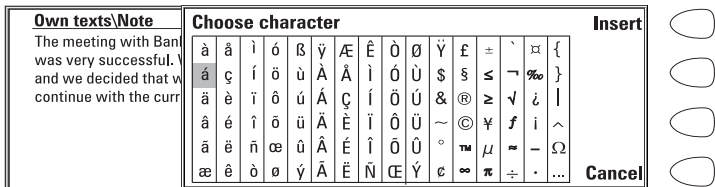

Figure 2

## To insert special characters from the keyboard

- 1 Press and hold the Chr key and simultaneously press a key with a special character printed on the key as the third character. The special key will be inserted on the display.

In addition, special characters can be generated using certain unmarked keys, for example, "a" and "e":

- 1 Press and hold the Chr key and simultaneously press a letter key. The first special character is displayed.
- 2 Continue to hold down the Chr key and press the letter key again. The second special character is shown in the place of the first, and so on, until the first character is shown again. The case of the special character is determined by whether Shift or the Caps lock key has been pressed.

## To send documents

When you press **Send** in the Notes editor, the following options become available:

*Send as fax* — You can send the document as a fax. This option opens the fax directory. The sending procedure from this point on is similar to that described in "To send faxes" on page 69.

*Send as short message* — You can send the document as a short message. The sending procedure is similar to that described in "To send short messages" on page 76.

*Send as mail* — You can send the document as an e-mail message. The sending procedure is similar to that described in "To send mail" on page 90.

## Downloaded files and read-only documents

All downloaded and captured texts can be opened in the Note editor.

Received short messages, received mail and ASCII text files transferred to the communicator are read-only documents. Read-only documents themselves cannot be edited, but an editable copy can be created:

- 1 Open a read-only document. The contents are shown as plain text.
- 2 Press any character key. You will be asked if you want to create an editable copy.
- 3 Press **Create** to close the original file and copy its contents to a new text file. If the original file is in DOS format, it will be removed after an editable copy has been created.
- 4 Edit the new note normally.

The contents of a received fax cannot be converted into text or edited. Opening a fax activates the fax viewer and opening an image activates the image viewer.



## Notes settings

You can change the default settings of the note editor by pressing **Settings** in the Notes main view. The settings are valid until they are changed again.

To change the settings, choose a setting and press **Change**.

*Font: URW Mono / URW Roman / URW Sans*

*Size: 10 points / 12 / 14 / 18 / 24 / 36 / User defined*

*Margins* — Opens a new view where you can define values for the top, bottom, left or right margin. The unit of measurement used in this setting is either inches or centimetres, and it can be changed in the System settings.



# 11. Calendar

In the Calendar application, you can check your scheduled events, keep a list of tasks in the To-do list, set alarms and link memos to events, and book events in other people's calendars.

**Tip:** In order to optimise the amount of data stored on your communicator and the operation of the Calendar, it is recommended that you regularly remove old calendar events with the Data removal function. See "Data removal" on page 132.

## Monthly schedule

The monthly schedule shows the days of the current month in rows according to the number of the week. The week number is shown in the column on the left.

Today's date is shown in a frame (in the figure 1, August 6th).

The currently selected date has a dark background with white digits (August 28th). Use the arrow keys to select another date.

Dates that have scheduled events are marked in **bold** (August 9th).

If the selected date contains scheduled events (as in the figure, August 28th), they are shown in a separate daily events list on the right side of the display. The schedule can be edited by selecting the date and pressing **Day** or the Enter key.

If the whole date has been reserved for an event, the event is shown in the daily events list in **bold** (as "Design conference" in figure 1).

To write yourself reminders of important matters, press **To-do list**.

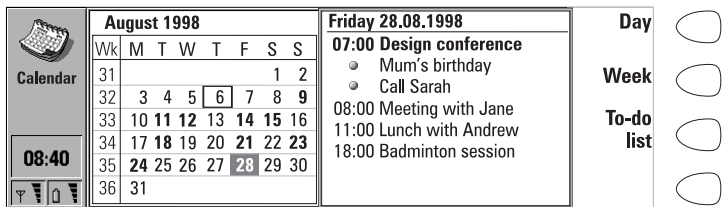

Figure 1

**Tip:** To add events to the monthly and weekly schedules, just start writing the event description. The Details view opens automatically.

## Weekly schedule

The weekly schedule shows the timetable of the selected week.

Today's date is outlined by a square frame (Tuesday 17th in figure 2).

The currently selected time box is shaded (Thursday 19th, 12:00 in figure 2).

All the events are marked with grey bars according to their start and end times. The bars are thinner if the events of the day overlap (Friday 20th in figure 2).

If the whole day has been reserved for an event, all the time boxes are marked with a dark grey bar (Tuesday 17th in figure 2).

To open the daily or the monthly schedule, press **Day** or **Month**, respectively.

You can use the arrow keys to scroll inside a day in the weekly schedule.

If you scroll to a time box containing an event, the bar across the bottom of the weekly schedule will show the basic details of the event. See figure 2. The numbers to the right of the event description indicate the number of events contained within that time box, e.g. "2/3" means that you are seeing the details of the second of three events.

If a time box contains more than one event, you may view the basic details of each event by scrolling to the time box and pressing the Tab key on the keyboard. The details will be shown on the bar across the bottom of the weekly schedule. To view the previous event, press Shift and Tab.

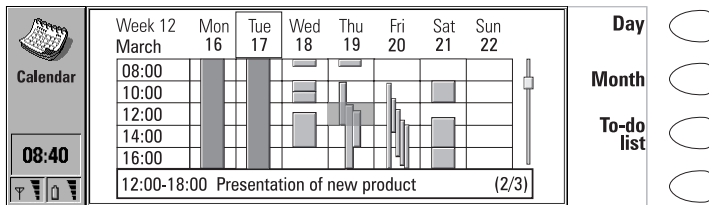

Figure 2

## Daily schedule

Open the daily schedule by pressing **Day** in the monthly or weekly schedule. The daily events list displays the schedule for the selected day. The contents of the entries are freely editable.

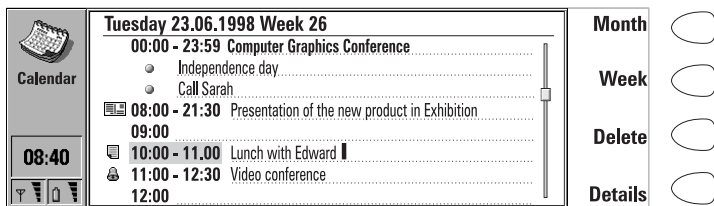







Figure 3

### Daily schedule symbols

-  — Attached alarms
-  — Calendar bookings
-  — Attached memos
-  — Recurring events
-  — Annual events

The symbols appear in the order of priority before the event description. See figure 3.

### To add events

- 1 Move the selection frame over the starting time of the event.
- 2 Type the event on the dotted line. If you want to add an event without a start time, write the event, press **Details** and remove the start time. The event will be shown with a dot in front.

**Tip:** If the starting time already contains an event, press **Enter** to create a new row with the same starting time.

### To remove events

Select the event and press **Delete**. If you remove or edit recurring events, you will be asked if you want to apply the changes to all or only to the selected event.

### To adjust the details of the selected event

Press **Details**. A new view opens, allowing you to adjust the following details:  
*Description* — The description of the event.

*Reserve whole day(s)* — You can write down the number of days required for the event.

*Start:*

*Date* — The date of the event. The default date is that of the selected day. The date format is set in the System settings.

*Time* — The time when the event starts.

*End:*

*Date* — The date when the event ends.

*Time* — The time when the event ends.

*Alarm* — Sets an alarm for the selected event. See "Alarms" on page 121.

*Frequency* — You can define how often the event repeats. The options are *None /Daily /Weekly /Monthly /Annually /Every other week /Working days*.

*Repeat until: [date]* — You can write down the last date of the recurring event.

*Event sent to* — Lists all the people to whom you have booked the event. The list shows the status of the sent event:

*Accepted or Confirmed* — The recipient has accepted the booking.

*Discarded* — The recipient has rejected the booking.

*No reply* — No information has been received from the recipient.

*Forced* — The booking was sent as a reservation.

## To attach memos to an event

- 1 Move the selection frame over the desired event and press **Details** in the daily schedule.
- 2 Press **Memo**.
- 3 Write the memo. The following command buttons are available:
  - Send** — You can send the memo as a fax, SMS or mail.
  - Style** — You can format the text.
  - Delete** — Removes the memo.
  - Close** — Links the memo to the selected event.

Memos are stored in the Calendar memos subfolder of the Own texts folder.

## To use the Menu button

When you press the Menu button in the monthly, daily and weekly schedules, the following options become available:

*To-do list* — Opens the To-do list. Available in the daily schedule only.

*Pending requests* — Opens the list of pending calendar event requests.

*Today* — Shows the current day.

*Next month/week/day (Ctrl-N)* — Shows the next month, week or day.

*Previous month/week/day (Ctrl-P)* — Shows the previous month, week or day.

*Settings* — Enables you to change the following options:

*Booking password* — You can set a password to protect your calendar from receiving reservations from anyone except those who have your password. The maximum length of the password is 8 characters. When a password is written in the field, all characters appear as asterisks.

*Default alarm* — When you set an alarm to an event, the alarm will go off 10 minutes before the scheduled time of the event, unless you specify otherwise here.

*Beginning of week* — You can select which day is considered to be the first day of the week.

## Calendar booking

Calendar booking enables you to send event requests or reservations to other communicators or calendar servers. The difference between an event request and an event reservation is that the recipient may decide whether to accept or discard an event request, but event reservations can only be accepted.

### Booking password

Sending event reservations requires that you know the recipient's booking password. If you add the recipient's password to the booking password field of the recipient's contact card, the password is automatically taken from there when you send a reservation.

When you send a reservation with an incorrect password, the recipient's communicator discards the reservation.

You can give your own booking password to those whom you allow to send reservations to your calendar. If you do not set a password, your communicator accepts all reservations.

Define your booking password in the Calendar settings.

**Note:** The recipient's booking password is not needed when you send event requests.

### To make requests and reservations

- 1 Select an event in the daily schedule or write a new one.
- 2 Press **Calendar booking** in the Details view.
- 3 Select whether to send the event as a request or a reservation.
- 4 Press **Transfer via IR** to send the booking to another Nokia 9110 Communicator via the infrared link, or press **Send as SMS** to open the SMS directory where you can select the recipient for the booking. Note

that the recipient must have a phone number in the *Tel(GSM)* field, or, if you are sending the booking to a calendar server, a server number in the *Tel(Server)* field.

- 5 Press **Send** to send the booking.

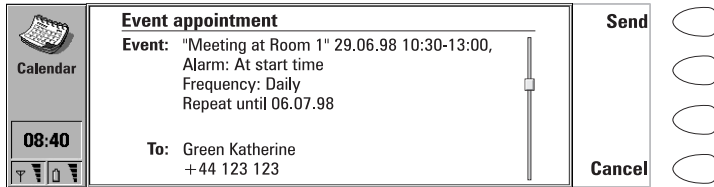

Figure 4

## To receive requests

When you receive an event request, a note appears on the display showing the details of the event, and the name or number of the sender. On the left side of the note is your schedule for the day, where you can check whether you have other appointments at the same time.

If you press **Accept** or **Deny**, your communicator sends a reply to the sender informing about your decision. Accepted events are moved to your calendar.

The received request can be dismissed by pressing **Cancel**.

If you press **Hold**, the event request is moved to the Pending requests list to wait for your decision. This list is accessed by pressing the Menu button in the monthly, weekly or daily schedule and selecting *Pending requests*. On the right side of the list is your schedule for the day, where you can check whether you have other appointments at the same time. The commands in the Pending requests list are **Accept** and **Deny**, the function of which is explained above; and **Delete**, which removes the event from the list.

**Note:** Old events are not removed when new events are added, even if they have the same date and time.

## To receive reservations

When you receive an event reservation, a note appears on the display giving the details of the event. When you press **OK**, the reservation is moved to your calendar. If you press **Confirm**, the event is moved to your calendar and a confirmation note is sent to the sender of the reservation.

## To cancel bookings

There are two ways to cancel bookings that you have sent:

- 1 Remove the event from your own calendar. Your communicator will check the "Event sent to" list (see "Daily schedule" on page 117) and send a



special SMS to all the participants who share the event, removing the event in their calendars as well. Or,

- 2 Select a participant in the "Event sent to" list and press **Cancel event**. The event is removed from the participant's calendar.

### To change a booking that you have sent

Select the event and press **Details**. Make the desired changes. The changes are sent to the calendars of the persons to whom you have sent the booking.

## Alarms

### To set an alarm to the currently selected event

- 1 Press **Details** in the daily schedule.
- 2 Select the *Alarm* option and press **Change**.
- 3 Select one of the alarm options:
  - None* – No alarm is attached to the event.
  - At start time* – The alarm will sound at the start time.
  - ... minutes before event* – The alarm will go off as set in the Calendar settings unless you specify otherwise here.

**Tip:** To set alarms that are not related to any calendar event, use the Clock application, see "Clock" on page 136.

You can choose the alarm tone in the System sounds settings of the System application.

An active alarm is indicated by the bell icon in the daily schedule (in the figure 3, the 11:00 event). When the alarm sounds, a note is shown on both displays.

The alarm sound can be turned off by pressing any key. If you have set the communicator to a silent profile in the Telephone settings, only the alarm note will be shown.

**Tip:** After a calendar alarm has occurred, you can move the message contents of the alarm to the To-do list by pressing **Move to To-do list**.

## To-do list

The To-do list is a list of tasks which must be completed eventually, but are not connected to any specific time or day. The entries in the To-do list are

numbered, and they can be given different statuses. High priority entries are shown at the top of the list. See figure 5.

### To access the To-do list

- 1 Press the **To-do list** command button in the monthly or weekly schedule.  
Or,
- 2 Press the Menu button and select the *To-do list* option in the daily schedule.

### To change the status of the selected task

- 1 Press **Priority**. A pop-up box opens.
- 2 Change the status of the entry to *High priority* or *Normal priority*, or mark the task as *Completed*, as the task number four in figure 5.

To write down a new to-do task, press **New**. An empty entry field is added at the end of the To-do list.

To remove the currently selected task from the list, press **Delete**.

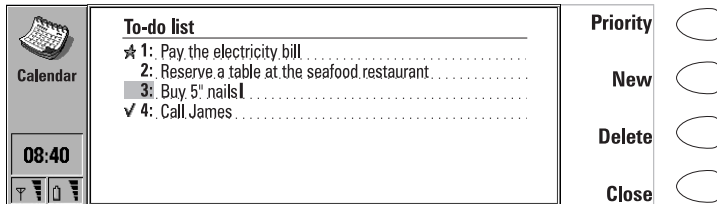

Figure 5

# 12. System

System contains the following applications: Security, User data, Memory, Infrared activation, Digital camera connectivity, Remote synchronisation, Fax modem, Data removal, Install/Remove software, Backup/Restore, Memory card tool, and About this product.

## To start a System application

- 1 Press the System application button.
- 2 Scroll to the application and press **Select**.
- 3 If a System application is active, you must close it by pressing **Close** in the main view of the application before you can start another.

**Note:** When one of the PC connectivity applications or the fax modem is in use, the communicator consumes more power than normally. To extend the battery operation time, these applications should be closed when they are not used.

## System settings

### To change the System settings

- 1 Press **Settings** in the System main view.
- 2 Select the setting you want to change.
- 3 Press **Change**.

The System settings include all system-related permanent settings:

*System sounds* — Covers all the sounds in the communicator. The available settings are:

*Default ringing tone* — You can select one of the tones in the pop-up box or compose a special ringing tone for your telephone with the Composer application. See "Composer" on page 139. You can also use the sounds you have recorded with the Digital voice recorder as ringing tones. See "Voice recorder" on page 142. If a tone or sound is erased, the default ringing tone Grande valse will replace it.

*Alternate ringing tone* — If your SIM card supports the alternate line service, you can select a different ringing tone for Line 2. See "Telephone settings" on page 63.

**Notification tones: On/Off** – Determines whether a sound is heard, for example, when the memory is too low.

**Application tones: Calendar alarm, Clock alarm, Received fax, Received SMS, Received mail** – For each of these items you can set a specific ringing tone. You would then be able to tell by the tone whether you have received a fax or a short message, for example.

The *None* option allows you to turn the selected tone off, with the exception of the clock alarm. Note that when the phone is turned off, only calendar and clock alarm ringing tones can be heard. This requires, however, that the ringing tones are set through the System settings.

**Print settings** – You can select the default settings for printing. For more about printing, see "Document features" on page 34.

**Connection type** – Select whether to use infrared or cable connection.

**Header** – Set this on if you want to print your name and the date and time of printing on the top of each page.

**Paper size** – Choose either *A4* or *Letter*.

**Default printer** – Select the printer used in the cable connection.

**Baud rate: 9600/19200/57600/115200** – Select the data transmission rate used in the cable connection.

**Flow control: Software/None** – You can select whether to let the software control the data flow.

**Data bits: 7/8** – Host-specific communication parameter for the cable connection.

**Parity: None/Odd/Even** – Host-specific communication parameter for the cable connection.

**Stop bits: 1/2** – Host-specific communication parameter for the cable connection.

**Backlight period** – You can set the time period for which the backlight is switched on. The available settings are *15/30/45 seconds /1/2/3/4/5 minutes*. The backlight can also be turned off by pressing the  button.

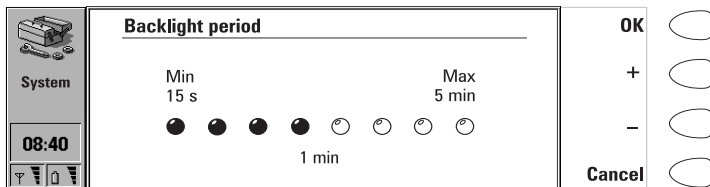

Figure 1

**Note:** Extensive use of the backlight may drain the battery.

*Screen blanker period*— You can set the time period after which the display will blank out if the device remains inactive. This feature saves the battery and increases the operation time of the communicator. The time-out period can be from 2 to 15 minutes. The screen blanker cannot be turned off.

*Contrast control*— The contrast view shows a test picture and a set of commands that can be used to adjust the picture. The + command button increases the contrast. The – command button decreases the contrast. When the setting seems satisfactory, press **OK**.

*Preferences*— Preferences lets you change date and time formats and the unit of measurement:

*Date format:* *dd.mm.yy / mm.dd.yy / yy.mm.dd.* — For example, 22.03.98 / 03.22.98 / 98.03.22.

*Time format:* *24 hour / AM/PM*— For example, 09:35 / 9:35 AM.

*Unit of measure*— Choose either *Centimetre* or *Inch* as the basic unit of measure.

## Security

**Note:** The predetermined default lock code 12345 is provided in the sales package of the communicator. For security reasons, it is imperative that you change the lock code. Change the code either in the Security options menu of the phone (see "Settings (Menu 4)" on page 157), or via the communicator interface (see "To change the security settings" on page 126). Keep the new code secret and in a safe place, separate from the communicator.

### To lock the communicator automatically

- 1 Press **Settings** in the main view of the Security application.
- 2 Select *Autolock period* and press **Change**.
- 3 Enter your lock code at the prompt, and define the autolock period. When the communicator remains inactive for the defined period, it will lock itself.

### To lock the communicator manually

- 1 Press **Lock system** in the main view of the Security application.
- 2 If the *Autolock period* is in use, the device will lock immediately. If the *Autolock period* is off, you must enter your lock code before the device is locked.

After the communicator has been locked, it cannot be used until the correct lock code is given. However, incoming voice calls can be answered via the phone, and faxes and short messages are received normally.

**Note:** When the communicator is locked, it may be possible to make a call via the phone to the emergency number programmed into your phone, e.g. 112 or other official emergency number.

### To unlock the communicator

- 1 Enter your lock code in the input field.
- 2 Press **OK**.

### To change the security settings

- 1 Press **Settings** in the Security main view.
- 2 Select the setting and press **Change**.
- 3 When you are prompted for a code, enter it and press **OK**.

Choose a new value.

**Tip:** Most of the security features can also be changed in the Security options menu of the phone. See "Settings (Menu 4)" on page 157.

The codes are shown as asterisks. If you are changing a code, you will be prompted for the current code and then the new code twice. The code cannot be changed if the corresponding security feature is not in use. For example, if the PIN code request is set to *Off*, the PIN code cannot be changed.

Pressing **Close** will close the security settings and return to the Security main view.

## Security settings

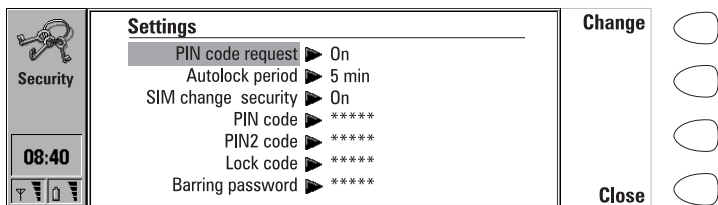

Figure 2

**PIN code request: On / Off** — If you set the PIN code request on, the communicator requests the code every time the phone is turned on by pressing **⓪**. This setting cannot be changed if the phone is switched off or if there is no valid SIM card inserted.

If you enter the PIN code incorrectly three times in a row, you will need a PUK code to unblock the SIM card. When the SIM card is blocked, you cannot send or receive any documents or calls, except emergency calls. Otherwise, the communicator can be used normally.

**Note:** Some SIM cards do not allow you to turn the PIN code request off.

**Autolock period: Autolock off/1/2/5/15/30/60 minutes** — Determines the security time-out period, after which the communicator will lock. The timer is reset by any input, calls, data transfer, printing, etc.

**SIM change security: On / Off** — When active, every time the phone is switched on this security option checks whether the SIM card in the communicator has been changed. If the SIM card has been changed and the new SIM card has not been used with your communicator previously, the communicator locks itself until the lock code is correctly entered. The communicator recognises five different SIM cards as the owner's cards.

**PIN code** — This setting allows you to change the PIN code. The changing procedure is described at the beginning of this "Security" section. The new PIN code must be 4 to 8 digits long. Changing the PIN code requires that the PIN code request is set on, the phone is on, and that there is a valid SIM card inserted in the communicator.

**PIN2 code** — This setting enables you to change the PIN2 code. The PIN2 code is required to access some functions, such as the call cost settings, which must be supported by your SIM card. If you enter an incorrect PIN2 code three times in succession, you will need a PUK2 code to unblock the PIN2 code. The length of the PIN2 code is 4 to 8 digits.

**Lock code** – This setting allows you to change the lock code. The changing procedure is described at the beginning of this "Security" section. The new code must be 5 digits long.

If you key in an incorrect lock code several times in succession, the communicator must be sent back to the dealer to be unlocked.

**Barring password** – This setting allows you to change the barring password. The new code must be 4 digits long. To change the password, the phone must be on and within the network coverage, the Call barring service must be activated for your SIM card which must be valid and inserted in the communicator.

If you enter an incorrect barring password three times, the password is blocked and you must ask the network operator for a new password.

**Note:** Avoid using codes that are similar to emergency numbers to prevent accidental dialling of the emergency number.

## User data

The User data card contains your personal information. You can freely edit the information in the *Name, Company, Job title, Address, Tel, Fax, Tel(GSM), Fax(GSM), Mail* and *URL* fields.

The User data will automatically be included in the corresponding fields of the fax cover page in the Fax application. Likewise, the SMS application uses this information when you send your own business card.

When you press **Attach image** in the user data card, you can attach your own picture to the card. The picture must first be stored in JPG format in the Contact images subfolder of the Downloaded files folder.

## Memory

This application shows the amount of available free memory for storing data and installing new software. Press **Details** to open up a list of folders and other data in the communicator. The list shows how much memory each of them takes up, and it is updated each time you press **Details**.

If your memory card is inserted in the communicator, press **Memory card** to check the amount of available memory in the card.

If the memory is getting low, you should remove some documents. Before removing, you can print, fax or mail them, or transfer them to a PC or a memory card.



## Infrared activation

If you want to use the PC Suite for Nokia 9110 Communicator program (see "To use the PC Suite" on page 39) with the infrared connection, or if you want to receive data from another device via the infrared, you need to use the Infrared activation application.

**Note:** A maximum of 20 files can be transferred at a time.

- 1 Make sure that the infrared port of the communicator faces the infrared port of the PC or another device.
- 2 Open the Infrared activation application on the communicator.
- 3 Press **Activate**.
- 4 To end the infrared connection, press **Disable**.

### To transfer data between two communicators

- 1 Make sure that the infrared ports of the communicators face each other.
- 2 Open the Infrared activation application on the receiving communicator.
- 3 In the sending communicator, go to the application from where you want to transfer data, and press **Transfer via IR**.

**Tip:** The infrared link can also be activated by pressing Chr-1 on the communicator keyboard.

## Digital camera connectivity

The Digital camera connectivity application enables you to transfer images between your communicator and a digital still camera or another communicator via the infrared connection.

**Note:** The infrared protocol of the digital camera must be IrTran-P in order to be compatible with the Nokia 9110 Communicator.

When you start the application, press **Image list** to open a list of the images in the Downloaded files folder. However, you can only select image files with the extensions UPF or JPG.

### To transfer images from another device to the communicator

The connection to a digital camera or another communicator is always established by the receiving communicator.

- 1 Make sure that the infrared port of your communicator faces the infrared port of the other device.
- 2 Open the Digital camera connectivity application and press **Image list**.
- 3 Press **Receive** to start transferring the selected UPF images from the other device to your communicator.

### To transfer images from the communicator to another device

- 1 Open the Digital camera connectivity application and press **Image list**.
- 2 Select the UPF image(s) you want to transfer.
- 3 Make sure that the infrared port of your communicator faces the infrared port of the other device, and press **Send**.

To rename the selected image, press **Rename** and write the new name in the input field. Do not change the extension at the end of the name.

### To use the Menu button

When you press the Menu button in the Image list, the following options become available:

*Open* — Opens the image. When the image is open, you can print it, or send it as SMS, fax or e-mail.

*Delete* — Removes the image.

*Convert to JPEG* — Converts the selected image(s) from UPF to JPG format.

*Convert to UPF* — Converts the selected image(s) from JPG to UPF format.

*Image information* — Presents information about the image. You can also view the information with the Ctrl-i key combination.

## Remote synchronisation

To synchronise your calendar data with a PC calendar, use the Remote synchronisation application. With this application, you connect to the PC via the Internet. Note that you need an Internet access point, see "Internet settings" on page 84.

The PC Suite for Nokia 9110 Communicator program must be running on the PC to which you are connecting.

### To synchronise calendar data

- 1 Press **Settings** and define the destination host, which is the IP address of the server PC, and select the Internet access point used.
- 2 Press **Start**. A data call is made, and the calendar data is sent from your communicator to the destination host.
- 3 When the synchronised calendar data has been sent back to your communicator, the data call ends.

## Fax modem

Before your PC can recognise the communicator as a fax modem, the PC needs to be properly configured. Consult the user's guide of your PC on how to install new modems. PCs with Microsoft Windows 95 or NT 3.51 or higher operating systems can use the modem information file found on the diskette supplied in the communicator sales package. See also the Documentation section on the CD-ROM.

Using the communicator as a fax modem requires that data calls are supported by the network you are using and that this service is activated for your SIM card. Contact your home service provider for details.

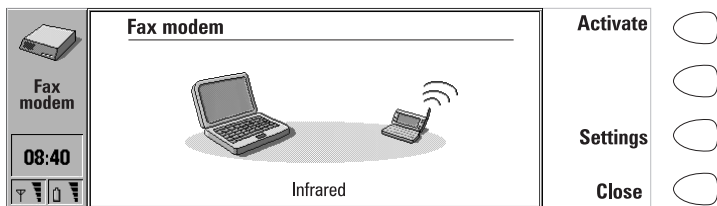

Figure 3

- 1 Press **Settings** and select the connection type. The functioning of a cable connection when the communicator is used as a fax modem is not guaranteed.
- 2 Connect the communicator to the PC via an infrared link as described in "To use the PC Suite" on page 39.
- 3 Wait until the connection is established.
- 4 Press **Activate** in the Fax modem main view. This will change the communicator to a fax modem. When the communicator is used as a fax modem, the call status indicator shows the text MODEM.
- 5 To stop using the communicator as a fax modem, press **Disable**.

The operations of a modem can be controlled by AT commands and S-registers. These commands give the advanced user an opportunity to control all the features of the modem. Should you need to enter the commands manually, consult the documentation of the PC application that you are using. A list of common AT commands based on the ETSI 07.07 standard and supported by the Nokia 9110 Communicator are available in the *atcomm.txt* file on the diskette included in the sales package of your communicator.

When the communicator is used as a fax modem, its normal communication features are disabled. Otherwise, the applications remain functional.

If an active PC connection is idle for longer than 20 minutes, the fax modem is automatically disabled to conserve power. However, when the communicator is connected to an electrical outlet, for example, while charging a battery, the time-out is not active.

## Data removal

The Data removal application comes in handy if you want to remove personal information from the communicator, for example, before lending it to someone else. In this way you need not remove data one by one.

- 1 Select what kind of data you want to remove. The removable data is arranged in four groups: *All device data*, *Calendar data*, *Documents*, *Contacts and speed dials*.
- 2 Press **Delete**.
- 3 Before any data is removed, you must enter your lock code. See "Security" on page 125. When removing calendar data, you can choose to remove all calendar data or only events that occur before a given date.

**Note:** Even if you choose the *All device data* option, your Internet settings will not be removed. If you want to restore your communicator to the same state it was in at the time of purchase, see chapter 15 "Troubleshooting" on page 163.

## Install/Remove software

The Install/Remove software application enables you to install new software from a PC to the communicator and later remove the software.

**Caution:** Beware of viruses! Only install on the Nokia 9110 Communicator software you have obtained from sources that offer adequate protection against viruses.

To use this application, you need to start the Nokia Communicator Server on your PC and connect your communicator to the PC. See "To use the Nokia Communicator Server" on page 46.

Press **Install** and select the software you want to install, or press **Remove** and select the software you want to remove.

The set of applications that were on the communicator at the time of purchase cannot be removed. This is to ensure that the basic functions of the communicator are always available.

**Tip:** To save the memory space of the communicator, you can install software to a memory card.

## Backup/Restore

The Backup/Restore application enables you to make backups of various data on your communicator, and to restore it later. Data is backed up in sets which are stored in separate directories on the PC.

To use this application, you need to start the Nokia Communicator Server on your PC and connect your communicator to the PC. See "To use the Nokia Communicator Server" on page 46.

Select whether to backup *All data*, *Documents*, *Contacts*, or *Calendar* and press **Backup**. A backup directory will be created if necessary.

The restoration procedure is carried out in the same way as the backup operation, except that instead of **Backup** you must press **Restore**. When data is restored, files with similar names in the destination folder will be overwritten.

**Note:** While the Backup/Restore is in progress, the other applications of the communicator cannot be used. To interrupt the operation, for example, to make an emergency call, press **Cancel** and confirm by pressing **Interrupt**.

To make backups or restore data between a Nokia 9000 Communicator or a Nokia 9000i Communicator and a Nokia 9110 Communicator, see "To transfer data from older communicator models" on page 37.

**Tip:** While travelling, you can make backups of important documents to a memory card.

## Memory card tool

The Memory card tool application can only be started if there is a memory card inserted in the communicator.

With this application, you can format and rename the memory card, and check the condition of the files.

## About this product

This application displays information about the Nokia 9110 Communicator.



# 13. Extras

Press the  button on the keyboard to open the Extras application group, which contains Calculator, Clock, Composer and Voice recorder. With Extras you can also launch applications located on your memory card.

**Note:** More applications can be installed to your communicator from the CD-ROM included in the sales package.

To start one of the applications, select it and press **Select**.

To close an active application, press **Close**.

**Tip:** With one Extras application active, you can quickly switch to another by pressing the  button.

## Calculator

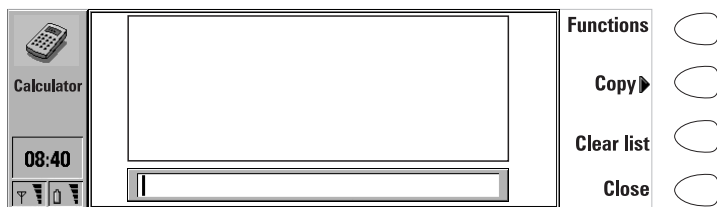

Figure 1

The Calculator contains an input field at the bottom of the screen, and above it a list where previous calculations, if any, can be seen. The most recent calculations are shown at the bottom of the list.

The list can be scrolled with the arrow keys, and it can be emptied by pressing **Clear list**.

The results of the calculations appear in **bold**. As long as you have not pressed Enter or "=", you can move in the calculation string with the arrow keys and edit the string.

The following characters can be used for the corresponding operations:

Character	Function
Numbers 0 to 9	
. (full stop)	decimal point
+	addition
-	subtraction
*	multiplication
/	division
( )	brackets
= or Enter	sum
Esc	clears the entry field

### To add functions in the input field

- 1 Press **Functions**.
- 2 Select one of the available categories and press **Select**. You will see a list of functions and you can select the one you want. You can select several functions before returning to the Calculator main view.

### To copy calculations in the input field

- 1 Press **Copy** to select and copy a calculation or a result back to the input field for modification or recalculation.
- 2 To copy a calculation, press **Copy calculation**, and to copy a result, press **Copy result**.
- 3 Press **Back**. The selected item will be copied to the input field.

### To change the mode of the calculator

When you press the Menu button in the Calculator main view and select *Settings*, you can change the mode of the calculator. Select either *Radians*, *Degrees*, or *Gradients*, and press **OK**.

## Clock

The Clock shows the time and date in your home city and country, as well as in several other cities and countries in the world. The Clock also includes an alarm clock.



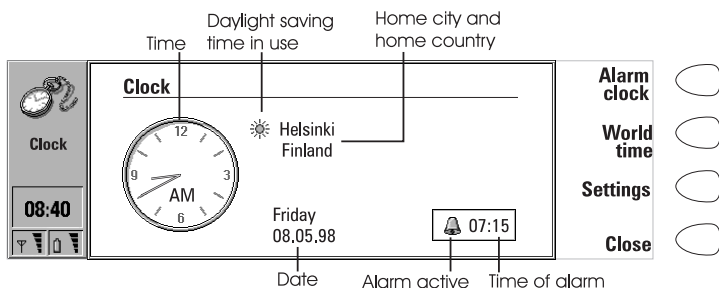

Figure 2

### To set an alarm

An alarm can be set to occur within the next 24 hours. Alarms that occur later than this are set in the Calendar application.

- 1 Press **Alarm clock** in the Clock main view.
- 2 Press + or - to adjust the time shown in the alarm clock display. Each press changes the time by one minute, but if you hold the button down a while longer, the time will start to change in 15-minute steps.
- 3 Press **OK** to accept the set alarm. When an alarm is set, the bell icon and the time of the alarm are shown in the Clock main view.

There can only be one active alarm. If an alarm is already active, the command names are different. A counter on the lower right side of the screen shows how much time remains to the time of the alarm.

Press **Change alarm time** if you want to readjust the time of the alarm.

Press **Delete alarm** to cancel the alarm.

**Note:** Alarms will occur according to the home city time. When in a different time zone, remember to change the home city.

### To turn off the alarm sound

- 1 When the alarm sounds, press any phone or communicator keyboard key to silence it.
- 2 Press the **OK** command button. If you do not press **OK**, the alarm will sound four more times or until you press the **OK** button. However, if the alarm interval is set to zero, the alarm will sound only once. Set the alarm interval in the clock settings.

## World time

World time (figure 3) is accessed with the **World time** command in the Clock main view.

The *Home* box shows the name of the currently selected home city, country, time, date and whether daylight saving time is in use.

The *Destination* box shows the same information for the currently selected destination city, as well as the international call prefixes needed to make a call from the home city to the destination city.

The world map shows the currently selected destination city in cross hairs.



Figure 3

### To select the destination city

- 1 Press **Set destination**.
- 2 Select a city from the list by scrolling the list with the arrow keys.
- 3 Press **OK**.

**Tip:** A quick way to select a city from the list of cities is to type the first letter of the city with the keyboard. The selection frame jumps to the first city starting with that letter.

### To edit and add cities

- 1 Press **Cities** in the world time view to open a list of cities.
- 2 To make changes to existing cities, press **Edit city**. The city information is presented in the form of a card with the following fields:

*City*— The name shown in the list of cities. Can be entered manually.

*Country*— The name of the country associated with the city. The country name is selected from the list of countries.

*Area code*— The area code required when calling the city. The area code can be entered with or without a national prefix. Only numbers can be entered.

*GMT offset* — Indicates by how much the local time differs from the Greenwich Mean Time. Select a value for the offset from a list. The offset can range from -12 to +12 hours.

*Set position* — Opens a world map view where you can determine the position of the city by moving the cross hairs with the arrow keys. When the city is where you want it to appear, press **OK**.

To create a new city card, press **Add city**.

To remove a city from the list, press **Delete city**. The current home city cannot be removed; you will have to change the home city first.

## To change the Clock settings

- 1 Press **Settings** in the Clock main view.
- 2 Select the setting you want to change and press **Change**, or type the new time or date from the keyboard.

*Home city* — Select the home city by scrolling the list of cities with the arrow keys. When your home city has been selected, press **OK**. If you select a city that is in a different time zone than your current home city, the system time will change.

*Time* — Enter the new time. The time format is selected in the System settings.

*Date* — Enter the new date. The date format is selected in the System settings.

*Alarm interval: 0/1/2/3/4/5 minutes* — Choose the interval between alarms. If you select *0*, the alarm will go off only once.

*Daylight saving* — You can set the daylight saving time of the home city and destination city *On* or *Off*. This setting remains the same even if the home/destination city is changed.

**Note:** Changing the time or daylight saving time of the home city will also adjust the time of the whole time zone, as well as the system time. If a set alarm is skipped because of a changed time, the alarm will go off immediately.

## Composer

The Composer application enables you to create your own, customised ringing tones.

To start the composer for the selected tune, press **Open**.

To compose a new tune press **Compose**.

To play the selected tune, press **Play**. While the tune is being played, the command changes into **Stop playing**.

**Note:** You can change the phone ringing tone in the Profile settings of the Telephone application or in the System sounds setting of the System application. See "Telephone settings" on page 63 and "System settings" on page 123.

### To edit a tune

- 1 Open a tune or press **Compose**. A cursor appears at the bottom of the screen, indicating the currently selected note or rest.
- 2 To create a note or to alter the pitch of the note, press the up or down arrow keys. Each press changes the pitch of the note. A rest will appear after all possible note levels have been scrolled through.
- 3 To move the cursor, press the left or right arrow keys.

**Note:** To edit the preset tunes that were in the communicator at the time of purchase, press the Menu button and select *Copy*.

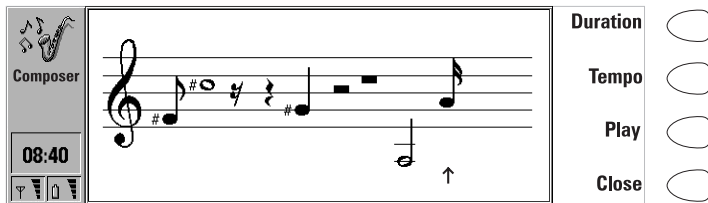

Figure 4

When a composition is being made, the following commands are available:

**Duration** changes the length of the selected note. Choose a quarter note, half note, whole note, sixteenth note, or eighth note. Press the command button until the value you want is shown.

**Tempo** opens a pop-up box with a new set of commands. Tempo is measured in beats per minute. To alter the tempo, remove the old value with the backspace key and enter the new value in the input field.

To accept the tempo, press **OK**.

To test the tempo, press **Test**. The tune will be played with the tempo

shown in the entry field.

To use the default tempo 160 beats/min., press **Default**.

**Play** plays the composition shown on the staff.

To remove a composition, press the Menu button, and select *Delete*.

To restore the tune to what it was before editing, press the Menu button and select *Undo changes*.

**Close** returns to the Composer main view.

### To use shortcuts

While editing, you can use the following shortcuts:

Character	Function
Enter	Plays the tune
: (colon)	Staccato
- (hyphen)	Inserts a rest
Space bar	Inserts an empty column to the left of the cursor.
Backspace	Deletes the selected column containing a note or a rest.
. (full stop)	Lengthens the duration of the note or rest by half

**Tip:** For quick composing, press the corresponding letter key on the keyboard to generate a note. For example, pressing D generates the note D. When you press Shift and a letter key, a sharp note is generated, e.g. Shift-D generates D sharp.

### To use the Menu button

When you press the Menu button in the Composer main view, the following options become available:

*Copy* — Copies the selected tune.

*Delete* — Removes the selected tune(s).

*Rename* — You can write the new name into the input field.

*Send as SMS* — Opens up the SMS directory where you can select a recipient for the composition(s). To send the composition(s), press **Send**.

When you receive a composition via SMS, a note showing the name or number of the sender and the name of the sent composition will appear on the display.

To add the composition to the list of tunes, press **Accept**. To discard the composition, press **Cancel**.

*Transfer via IR* — Enables you to send tunes from one communicator to another via the infrared link. The IR port of the receiving device must be activated before the operation. See "Infrared activation" on page 129.

*Copy to memory card* — Copies the selected tune(s) to the memory card.

*Copy from memory card* — Copies the selected tune(s) from the memory card to your communicator.

## Voice recorder

The Voice recorder allows you to record telephone conversations and voice memos. You can also listen to your recordings and other sound files. The maximum length of a recording is 30 seconds.

**Tip:** With the Voice recorder you can record sounds and speech and set them as ringing tones. See "Telephone settings" on page 63.

The main view of the Voice recorder shows a list of all the sound files currently stored in your communicator. To open the selected file, press **Open**. **New file** creates a new file into which sound can be recorded. **Delete** allows you to remove the selected file.

When you open a sound file, you will see the length, which is measured in seconds, and the size, which is measured in kilobytes, of the file.

**Note:** Local laws may apply to recording conversations. Do not use this feature illegally.

### To play a recording

- 1 Open the file and press **Play**.
- 2 The **Pause** command temporarily stops the playing of the sound file. To start playing again, press **Continue**.
- 3 To stop playing, press **Stop**.

### To record

- 1 Open the file into which you want the sound to be recorded, and press **Record**. If you are recording a telephone conversation, both parties will hear a tone when the recording starts.

- 2 You can stop the recording for a while by pressing **Pause** and then start again by pressing **Continue**.
- 3 To stop the recording, press **Stop**.

**Note:** To record sound and speech you need to have the phone turned on and within range of network coverage.

### To use the Menu button

When you press the Menu button in the Voice recorder main view, the following commands become available:

*Rename* — Renames the selected recording.

*Copy to memory card* — Copies the selected recording to the memory card.

*Copy from memory card* — Copies the selected recording from the memory card to your communicator.

**Note:** Sound files that the voice recorder can play have a .WAV extension and support the following audio format: 8, 11, 22 or 44khz, PCM/A-law, Stereo/Mono, 8bit.





# 14. Phone

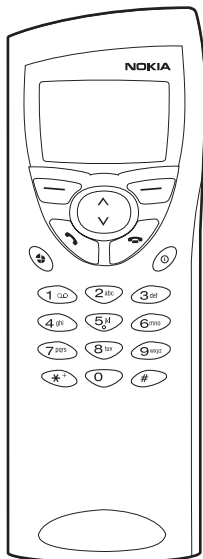

Figure 1

When operating the phone, keys are pressed one at a time. Two keys are never to be pressed simultaneously. The phone keypad is not functional when the device cover is open.

- ⓘ — Switches the phone on and off.
- ↻ — Switches between different profiles. See "Profiles (Menu 3)" on page 156.
- ∨ ^ — Scroll through menus, submenus or settings. If there are no active calls, the scroll keys can be used to browse through the memory contents. When a call is active, pressing the scroll keys adjusts the volume level.
- 📞 — Dials a phone number and answers a call.
- 📞 — Ends any active call, cancels a dialled call, or clears the display.

- 0 ... 9 — The number and alphabet keys. To call your voice mailbox, press and hold 1.
- \* # — Used for special purposes in certain functions. If you have subscribed to two phone lines, you can switch between them by pressing and holding #.
- — The function of these two selection keys depends on the text shown on the bottom line of the display. See figure 2.

**Note:** Hold the phone as you would any other telephone with the antenna pointed up and over your shoulder.

As with any other radio transmitting device, do not touch the antenna unnecessarily when the phone is switched on. Contact with the antenna affects call quality and may cause the phone to operate at a higher power level than otherwise needed.

### To use the selection keys

When this manual instructs you to press a command key, press the selection key under the command name. For example, pressing **Menu**, i.e. the selection key under the text *Menu*, gains access to the menu functions, and **Names**, i.e. the selection key under the text *Names*, to the search functions. The commands vary according to the situation and previous selection.

The selection must often be confirmed by pressing **OK**. Whenever the **Back** command is shown, it can be used to return to the previous menu level without making any changes.

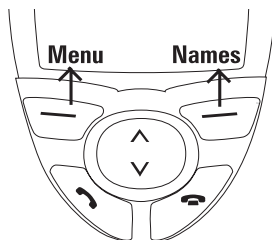

Figure 2

## Display indicators

The display indicators inform you about the current operation of the phone. The indicators described below are shown when the phone is ready for use, with no characters entered by the user on the display.

**OPERATOR**

Indicates in which cellular network the phone is currently used.

 and bar

Indicates the current signal strength at your location. The more bars are visible, the stronger is the signal.

 and bar



Indicates how much charge there is left in the battery. The more bars are visible, the more charge is in the battery

## To make a call

You can make and receive calls only when the phone is switched on, the communicator has a valid SIM card fitted, and it is located in the service area of the cellular network.

**Note:** In some networks emergency calls to the international emergency number 112 may be made without a SIM card. Check with your network operator. For more information about making emergency calls, see "Emergency calls" on page 173.



- 1 Key in the area code and the phone number of the person you wish to call. If you make a mistake, you can remove the digits one at a time by pressing **Clear** repeatedly, or clear the whole display by pressing and holding **Clear**.  
For international calls, start by pressing \* twice quickly. The international call character + appears on the display, which informs the network centre to select the country-specific international prefix. Enter the country code, area code and the phone number.
- 2 Press  to dial the phone number.
- 3 When the phone number disappears and the text *Call 1* is shown, the call is connected.

When a call is active, you can use the  and  keys to lower or raise the volume level of the earpiece.

**Note:** The microphone and earpiece are on the rear of the device.

- 4 After the conversation, end the call by pressing .

## To answer a call

- 1 When you receive a call, the phone gives a ringing tone and the text *Call* flashes on the display. If you have selected a silent profile in Menu 3, only the keypad and display lights will flash.  
If the caller can be identified, the caller's name or phone number, and the text *Calling* will be displayed.
- 2 To answer the call, press . You can answer the call even while using the search or menu functions.  
If you do not want to answer the call, simply press . The caller will hear the alerting tone change to a busy tone.
- 3 After the conversation, end the call by pressing .

## To manage calls

There are a number of functions you can use during a call. To access the functions, simply press **Options**, scroll to the function and press **Select**.

*Menu* — You can access *Menu*.

*Answer* — You can answer an incoming call.

*Reject* — You can reject an incoming call.

*Record* — You can record your conversation with this option. See "Recorder (Menu 6)" on page 162.

*Hold / Unhold* — *Hold* allows you to put the current call on hold, so that another call can be made. The original call can be activated again by selecting *Unhold*. If the held call is the only call, you can unhold it by pressing  or the **Unhold** command.

*Swap* — This function makes a held call active and put a currently active call on hold. You can thus alternate between two calls.

*New call* — Puts the active call on hold and dials a new phone number.

*Send DTMF* — Transmits DTMF tones. See "To send DTMF tones" on page 150.

*End this call* — Ends the active call.

*End all calls* — Ends both the active and the held call.

*Mute / Unmute* — Switches the microphone of the communicator off or on. If the communicator is connected to a handsfree car kit, *Mute* also turns off the microphone of the car kit.

*Conference* — If you have one call active and another call on hold, this option merges them into a conference call.

*Conference / One to one* — *Conference* includes a new participant in a conference call. During a conference call, *One to one* allows you to converse privately with a selected participant.

*Transfer* — The voice call transfer enables you to connect two voice calls together and disconnect yourself from both calls. See "Multiple calls" on page 60.

*Data* — When you have an alternating call active, this option changes the mode of the call from voice to fax. See "Multiple calls" on page 60.





*Voice* — When you have an alternating call active, this option changes the mode of the call from fax to voice.

*Play last* — Plays the last recording made with the recorder. The other party will also hear the recording.



**Tip:** If you have one active and one held call, press **Swap** to make the held call active and to put the currently active call on hold. In this way, you may converse with one party without ending the other call. You can also press  to swap between the calls if no numbers have been keyed in.

## To search for phone numbers

You may fetch phone numbers from memory by the name with which the required phone number was stored. Note that the phone uses memory (SIM or Telephone) which is chosen in the Telephone application by pressing **Menu** and **Select**.

- 1 Press **Names**.
- 2 Key in the name of the person whom you want to call, or the first letter(s) of the name.
- 3 Press **OK**. The name closest to the keyed in characters will appear.
- 4 If the name found was not the one you searched for, scroll through the names with  or  until you reach the correct one.
- 5 To call the person, press . If the person has several phone numbers, scroll the selection frame onto the one you want and press .

### To view the phone number stored with the name

- 1 When the desired name is on the display, press **Detail**. The phone number is displayed. If the person has several phone numbers, scroll through the numbers with  or  until you reach the correct one.
- 2 To call the number, press .

## To use speed dialling

Speed dialling is a handy way to call frequently-used phone numbers. You can define up to eight speed dial numbers in the communicator memory. For information on how to set speed dials, see "To make contact cards" on page 51.

- 1 Key in the number of the speed dial location where you have stored the





phone number.

- 2 Press . The phone will display the phone number briefly, and then dial it. Speed dialling is not possible during a call.

**Note:** Number 1 is the speed dial location of your voice mailbox. To call your voice mailbox, press **1** and then , or just press and hold **1**.

## Last number redial

The communicator stores the last phone numbers you have dialled.

- 1 If there are any characters on the display, clear the display by pressing .
- 2 Press . The last dialled number will appear on the display.
- 3 You can scroll the numbers with  or  until the desired number is displayed.
- 4 Press  to dial the number.

You can also recall recent received calls and recent missed calls, see "Call register (Menu 2)" on page 154.

## To send DTMF tones

If you need to send long DTMF strings, it is more convenient to send them via the communicator interface, see "Multiple calls" on page 60.

### To send DTMF tones manually

- 1 Make a call to the desired phone number.
- 2 Key in the digits you want to send as DTMF tones. The digits are sent one by one to the network. DTMF tones can be transmitted even when the phone key click is set off.

## Keypad lock

The keypad lock prevents the keypad keys being accidentally pressed when the communicator is, for example, in your pocket.

When the keypad is locked, you can answer calls normally by pressing . During a call, the keypad is unlocked and the communicator can be operated in the usual way. After the call, the keypad is automatically locked again.

The keypad will be automatically unlocked when the communicator is connected to a car kit. When the communicator is removed from the car kit, without having been switched off, the keypad will be locked automatically again.

### To lock the keypad

- 1 Press **Menu** and then the \* key within 3 seconds.

While the keypad is locked, the  icon and the **Unlock** command are displayed.

### To unlock the keypad

- 1 Press **Unlock** and then the \* key within 3 seconds.

**Note:** When the keypad is locked, calls may be possible to the emergency number programmed into your communicator (e.g. 112 or other official emergency number).

## Help

Most menu functions are provided with a help text, which gives a brief description of the displayed function.

### To view the help text

- 1 Scroll to the menu function about which you want help.
- 2 Wait for 10 seconds. The first page of the help text will appear. The text scrolls automatically. However, if you want to scroll it manually, press the scroll keys or **More**.
- 3 To exit from the help function, press **Back**.

## To use the menus

The phone offers a set of menu functions that allow you to tailor the phone to your particular use. In each menu and submenu, you can check and alter the settings of functions. The menus and submenus can be entered by scrolling the menu or using the appropriate shortcuts.

You can access the menu functions even during a call.

### To scroll the menus

- 1 Press **Menu**.
- 2 Press either  $\nabla$  or  $\blacktriangle$  to scroll the list of menus until you reach the desired menu.
- 3 Press **Select** to enter the menu. If the menu contains any submenus, reach the one you want with either  $\nabla$  or  $\blacktriangle$ .
- 4 Press **Select**. The selection frame is on the current setting.

- 5 Scroll the list of setting options until the selection frame is on the desired option.
- 6 Press **OK** to select the option. If you do not want to change the setting, you can return to the previous menu level by pressing **Back**.

### To use menu shortcuts

All the menus, submenus and settings are numbered. This number is shown in the upper right corner of the display.

- 1 Press **Menu**.
- 2 Key in the number of the main menu under which the desired submenu is located.
- 3 Key in the number of the submenu where the function can be found.
- 4 Key in the number of the desired setting option.

For instance, to change the incoming call alert in the general profile to ring only once (Menu 3-1-2-1-3): press **Menu** to enter the menu facility, **3** to enter the Profiles menu, **1** to select the General profile, **2** to personalise the profile, **1** to modify the alert tones, and **3** to select *Ring once*.

### To exit from the menu

- 1 Press  or press and hold **Back**.

### Menu structure

The following menu table lists the names of the main menus and their submenus. Third-level menus are not shown here.

Menu	Function	Submenus
MENU 1	MESSAGES Y	1 Received short messages, 2 Info service, 3 Service command editor, 4 Voice messages
MENU 2	CALL REGISTER	1 Missed calls Y, 2 Received calls Y, 3 Dialed calls, 4 Erase recent call lists, 5 Show call duration Y, 6 Show call costs Y, 7 Call cost settings
MENU 3	PROFILES	1 General, 2 Silent, 3 Meeting, 4 Outdoor, 5 Pager, 6 Flight, 7 Headset, 8 Car
MENU 4	SETTINGS	1 Call settings, 2 Phone settings, 3 Security settings, 4 Restore factory settings
MENU 5	CALL DIVERT Y	1 Divert all voice calls, 2 Divert when busy, 3 Divert when not answered, 4 Divert if not reachable, 5 Divert all fax calls, 6 Divert all data calls, 7 Cancel all diverts
MENU 6	RECORDER	



Some menu functions are network services, indicated by the **Y** symbol in the menu table. To use such a function, your network must support it and you must subscribe to it. Note that network services are specific to each SIM card. If you change the SIM card, and you have not obtained the service for the new card, you will not be able to use the service.

## Messages (Menu 1)

The Short Message Service (SMS) is a network service. Contact your service provider for details. The phone can be used for listening to voice messages in voice mailboxes and for reading received short messages. However, reading short messages is more convenient via the larger display of the communicator interface. To send short messages, use the SMS application of the communicator.

### Received short messages (Menu 1-1)

When you receive a short message, the text *Message received* and the  indicator will be displayed and a tone will sound, unless the communicator is set to a silent profile.

A note is also shown when you receive faxes or mail. To read received faxes or mail, you must use the respective applications of the communicator interface.

- 1 To read the message immediately, press **Read**. To read the message later, press **Exit**.
- 2 Press **Read** again to view the received message.  
The messages are listed in the order they were received. To read the second message on the list, press **∨** to select it and then press **Read**.

Once you have read the message, you can press **Back** or **Option**. The options available in the phone are:

*Erase* — Erases the selected message from the memory.

*Use number* — Copies the phone number from the message and moves it onto the phone display. You can now call the number with .

*Details* — Shows the sender's name or number, the date and time the message was sent, and the number of the message centre.

**Tip:** You can dial the phone number in the message by pressing  while viewing the message.

### Info service (Menu 1-2)

This network service allows you to receive short messages on various topics. You may read messages on topics that you have pre-defined on the communicator interface, see "SMS settings" on page 80.

- 1 Press **Select** to view the list of available choices.

- 2 Use  $\nabla$  or  $\wedge$  to scroll through the choice list. To get a list of messages, press **Read**.

Pressing **Select** gives you the following options:

*On* — Sets info message reception on.

*Off* — Turns info message reception off.

*Topic index* — Fetches a list of available topics from the network.

*Read* — Shows a list of received info messages. Scroll to the one you want to read and press **OK**.

*Language* — Sets the language for the messages. Scroll to the desired language and press **Mark**.

### Service command editor (Menu 1-3)

In this menu, you can send service requests, such as activation commands for network services, to your service provider. Key in the sequence you want, and press **Send**.

### Voice messages (Menu 1-4)

#### Listen to voice messages (Menu 1-4-1)

When you enter this menu, the communicator dials the phone number stored in menu 1-4-2. If required, key in the access code for your mailbox or answering machine when the connection has been made.

#### Voice mailbox number (Menu 1-4-2)

The phone number that you enter here will be dialled when you select the Listen to voice messages function in Menu 1-4-1. A voice mailbox can be a network service or your personal answering machine. You may enter a new or edit an existing phone number. The number will be used until you change the number again.

## Call register (Menu 2)

In this menu, you can check and erase phone numbers of calls that you have missed (Menu 2-1), received (Menu 2-2) or dialled (Menu 2-3). Note that the Received calls and Missed calls functions are network services which work only in networks that allow you to view the caller's phone number.

**Note:** The communicator only registers missed calls when the phone is switched on and within network coverage.

## Erase recent call lists (Menu 2-4)

**Caution:** The phone numbers are erased without warning. You cannot undo the operation.

## Show call duration (Menu 2-5)

In this menu, you can view the duration of your outgoing and incoming calls and reset the timers.

### Last call duration (Menu 2-5-1)

Shows the duration of the last outgoing or incoming call in hours, minutes and seconds, e.g. 00:02:15.

### All calls' duration (Menu 2-5-2)

Shows the total duration of all calls made or received with any SIM card that you have used with the communicator.

### Received calls' duration (Menu 2-5-3)

Shows the total duration of calls received with any SIM card that you have used with the communicator.

### Dialled calls' duration (Menu 2-5-4)

Shows the total duration of calls made with any SIM card that you have used with the communicator.

### Clear timers (Menu 2-5-5)

Resets all timers. There is no way to undo the reset operation.

**Note:** The actual time invoiced for calls and services by your service provider may vary, depending upon network features, rounding-off for billing, taxes and so forth.

## Show call costs (Menu 2-6)

This network service allows you to check various call costs. The costs are shown in charging units or units of currency that you have set in Menu 2-7-2. The call cost is shown for each SIM card separately. For these settings you need the PIN2 code. Contact your service provider for more information.

### Last call cost (Menu 2-6-1)

Shows the cost of the last, or current, call.

### All calls' cost (Menu 2-6-2)

Shows the total cost of all calls made with the current SIM card.

### Clear counters (Menu 2-6-3)

Resets all cost counters. Resetting requires the PIN2 code. This service is not available with SIM cards that do not support the PIN2 code. There is no way to undo the reset operation.

## Call cost settings (Menu 2-7)

### Call costs' limit (Menu 2-7-1)

This function allows you to limit the total costs of outgoing calls to a specified number of charging units or units of the currency that you have set in Menu 2-7-2. For this service you need the PIN2 code.

Changing the call cost limit also requires the PIN2 code. To turn the limit on, select *On*. Key in the cost limit in charging units or currency units. If you define the limit in currency units, you can press \* or # to insert a decimal point.

After the limit has been turned on, the number of the remaining units is shown on the display when in idle mode. When all units have been used, no calls can be made.

To turn the limit off, select *Off*.

**Note:** In some networks calls to the emergency number programmed into your communicator (e.g. 112 or other official emergency number) may be made even if there are no charging units left.

### Show costs in (Menu 2-7-2)

You may select whether the call costs and call cost limits will be displayed in currency or charging units. Contact your network operator for the prices of charging units. Changing the call cost unit requires the PIN2 code.

To show the limits in currency units, select *Currency*, or *Units* to show the limits in charging units. If you selected *Currency*, key in the charging unit price. Use \* or # to insert a decimal point. Next, enter the currency name.



## Profiles (Menu 3)

The profile settings are used for selecting the operating environment for the communicator, and for modifying the profile features. One profile is always in use.

### To set on a profile

- 1 Press **Menu**.
- 2 Scroll with  $\nabla$  and  $\blacktriangle$  to Profiles and press **Select**.

- 3 Scroll to the desired profile, for example *Meeting*.
- 4 Press **Options**.
- 5 Scroll to *Activate* and press **Select**. The name of the selected profile is shown on the display, except when the general profile is selected.

**Tip:** A quick way to set on a profile is to press the  key on the phone keypad. Press the key again until the selection frame is on the desired profile. To select the profile, press and hold .

For more information about the different profiles, see "Telephone settings" on page 63.



### To change the profile settings

- 1 Go to the Profiles menu and press **Select**.
- 2 Scroll to the desired profile and press **Options**.
- 3 Scroll to *Personalise* and press **Select**. For more information about the various profile settings, see "Telephone settings" on page 63.

## Settings (Menu 4)

### Call settings (Menu 4-1)

#### Anykey answer (Menu 4-1-1)

When set on, you can answer an incoming call by pressing any key on the phone keypad, except  or .

#### Automatic redialling (Menu 4-1-2)

When this function is set on and you call a number that is busy or does not answer, the communicator will attempt to call the number until the call is connected.

Press  to end the call attempts.

#### Speed dialling (Menu 4-1-3)

When set on, you can dial phone numbers stored in the speed dial locations by simply pressing and holding the assigned speed dial key.

#### Call waiting (Menu 4-1-4)

Call waiting is a network service. Contact your operator for subscription. See "Telephone settings" on page 63.

Choose *Activate* to enable call waiting, *Cancel* to disable call waiting, or *Status* to show call types with which call waiting may be used.

### Own number sending (Menu 4-1-5)

You can set your phone number to be displayed or hidden from the recipient of your call. This function works only in networks that allow you to view callers' phone numbers, provided that this service has been activated for your SIM card. Do not use this function unless it has been activated for your SIM card.

Choose *Preset*, *On*, *Off*, *Next on*, or *Next off*. *Preset* selects the setting, *On* or *Off*, that you have agreed upon with your network operator. When you change the SIM card, the *Preset* setting is automatically selected.

### Phone line in use (Menu 4-1-6)

If your network supports this service, you can have two phone lines in your communicator. You can select which line you want to use for making calls. For more information, see "Telephone settings" on page 63.

## Phone settings (Menu 4-2)

### Clock (Menu 4-2-1)

You can select whether the time is shown on the display.

### Cell info display (Menu 4-2-2)

When this function is set on, the phone will indicate when it is using a network cell based on Micro-Cellular Network technology. The setting will remain in effect even if the SIM card is changed or the phone is switched off.

**Note:** The communicator consumes more power when the Cell info display is on.

### Name list (Menu 4-2-3)

When searching for names and numbers, you can select whether to show three names, or one name at a time on the display.

### List of own numbers (Menu 4-2-4)

You can store and manage phone numbers assigned to your SIM card. This function is a memory aid, from which you can check your own phone numbers.

### Welcome note (Menu 4-2-5)

You can write a message of up to 30 characters which appears on the display when you switch on the phone.

- 1 Scroll to the *Welcome note* setting and press **Select**.
- 2 Key in the message.
- 3 Press **Options** and scroll to *Save* and press **OK**.

### Network selection (Menu 4-2-6)

The communicator can be set to select automatically one of the cellular networks available in your area. You may also select the desired network manually in this menu.

When the *Automatic* option is selected, the communicator tries to utilise the network on which it was last registered. Outside of the home network service area, the communicator will select one of the networks that have a roaming agreement with the home network.

In the *Manual* mode, when you pick up a network manually from the network list, the communicator will always attempt to register on that network. If the communicator cannot reach, or loses contact with, the selected network, you are prompted to select another network.

**Tip:** Network selection comes in handy when you want to select a particular network, e.g. due to lower call charges.

### Security settings (Menu 4-3)

The purpose of the security system is to prevent unauthorised use or altering of important settings. In most cases, activating or changing the security options requires the appropriate access code. See "Security" on page 125.

**Note:** When security features which restrict calls are in use (call diverting, call barring, fixed dialling, closed user group, or system lock), calls may be possible to certain emergency numbers in some networks (e.g. 112 or other official emergency number).

#### PIN code request (Menu 4-3-1)

*On or Off.* See "Security" on page 125.

#### Voice call barring (Menu 4-3-2)

Call barring is a network service; contact your operator for subscription. See "Telephone settings" on page 63.

- 1 Scroll to one of the following barring modes and press **Select**.  
*All outgoing calls*

*All international calls*  
*International except to home country*  
*All incoming calls*  
*Incoming calls when abroad*  
*Cancel all barrings*

- 2 If you want to take the selected barring mode into use, scroll to *Activate*; if you want to disable the selected barring mode, select *Cancel*, or if you want to check the status of the barring mode, select *Status*, and press **OK**.

### **Fixed dialling (Menu 4-3-3)**

You may restrict your outgoing calls to a pre-determined set of phone numbers, if supported by your SIM card. When the function is set on, you can only call a phone number which is included in the fixed dialling list or which begins with the same digits as a phone number on the list.

Enter the PIN2 code. Select *On*, *Off* or *Numbers*, with which to edit the fixed dialling list.

If you selected *Numbers*, the following options become available: *Search*, *Add entry* or *Erase all*. Selecting *Search* and subsequently *Options* opens *Edit* and *Erase*. The *Erase* and *Edit* options affect the name and the phone number that was on the display when you selected *Numbers*.

**Note:** The SIM card contents cannot be accessed if the Fixed dialling is on.

### **Closed user group (Menu 4-3-4)**

This network service allows you to set the communicator to accept calls to and from a selected group of people. For details on creating a user group and activating this service, contact your network operator. You may be a member of up to 10 user groups.

Select one of the following options:

*Preset* — Uses a user group that the SIM card owner has agreed upon with the network operator.

*On* — Uses a particular user group. Calls can be made to or received from the members of the selected group only.

*Off* — Calls can be made and received in the normal way. You can use this option only if you are entitled to do so.

### **SIM change security (Menu 4-3-5)**

The same settings can be found in the Security settings. See "Security" on page 125.

### **Change access codes (Menu 4-3-6)**



In this submenu, you can change the lock code, the PIN code, the PIN2 code and the barring password. See "Security" on page 125.

The access codes may only include the digits 0 to 9.

### System lock (Menu 4-3-7)

To lock the communicator, press **Select** and enter your lock code. The communicator locks immediately. Even if you remove and replace the battery and switch on the phone, the communicator will remain locked.

To unlock the communicator, press **Unlock** and enter the lock code.

### Restore factory settings (Menu 4-4)

You can reset the settings of the menu functions to their original values. When you activate this setting, you will be prompted for your five-digit lock code. This function will not affect stored phone numbers and names, access codes, earpiece volume setting, call timers, cost counters, selected application tones or short messages.

## Call divert (Menu 5)

The call divert network service allows you to direct your incoming voice calls to another phone number when you do not want to be disturbed, or when the phone is switched off or outside the network coverage area. The call diverting functions are described in more detail in "Telephone settings" on page 63.

- 1 Scroll to one of the following divert options and press **Select**:

- Divert all voice calls*
- Divert when busy*
- Divert when not answered*
- Divert if not reachable*
- Divert all fax calls*
- Divert all data calls*
- Cancel all diverts*

- 2 Scroll to *Activate*. You will be asked for the phone number to which you wish to divert the incoming calls.

The *Cancel* option sets the divert mode off. *Status* shows what kind of calls are being diverted.

## Recorder (Menu 6)

With the Recorder you can record your telephone conversations and voice memos, and listen to them. The maximum length of a recording is 30 seconds. See also "Voice recorder" on page 142.

**Note:** Local laws may apply to recording conversations. Do not use this feature illegally.

### To record your own speech

- 1 In the Recorder menu, press **Select**.
- 2 Scroll to *Record* and press **Select**.
- 3 To stop the recording, press **Stop**.

### To record your Telephone conversation

- 1 When you have an active call, press **Record**. When the recording starts, both parties will hear a tone.
- 2 To stop the recording, press **Stop**.

### To record your telephone conversation when you have more than one call

- 1 If you have for example one call active and another on hold, press **Options**.
- 2 Scroll to *Record* and press **Select**. When the recording starts, both parties will hear a tone.
- 3 To stop the recording, press **Stop**.

### To play a recording

- 1 In the Recorder menu, press **Select**.
- 2 Scroll to *List* and press **Select**.
- 3 Scroll to the recording you want to listen to, press **Options** and then **Play**.

### To play a recording when you have an active call

- 1 Press **Option**.
- 2 Scroll to *Play last* and press **Select**. Or, if you want to play an older recording, follow the steps above. The other party will also hear the recording.

# 15. Troubleshooting

**Tip:** You will find the Club Nokia Careline phone numbers in the Accessories guide. Club Nokia Careline answers questions and offers instructions over the phone.

You can also visit Nokia Wireless Data Forum at <http://www.forum.nokia.com> for information and support material related to the communicator.

## 1. Phone or communicator interface does not start; both displays remain blank

Make sure that the battery is properly installed and charged.

Make sure that the contacts on the battery and the charging stand are clean.

The battery charge may be too low for operation. Check the display and listen for the low battery warning tones. Charge the battery as described in "Battery" on page 27. If the NOT CHARGING message is displayed, the charging is suspended. In that case, check that the temperature of the battery is not above +45°C (+113°F). Wait for a while, disconnect the charger, connect it again and retry. If charging still fails, contact your local Nokia dealer.

## 2. Power comes on, but the phone does not work

Reboot the communicator by removing the battery and replacing it again.

Try charging the communicator. If you see the battery charging indicator on the phone but the phone does not work, contact your local Nokia dealer.

Check the field strength indicator: you might be outside the network service area. See the answer to problem number 6.

Make sure that the telephone service is activated for your SIM card.

Check if there is an error message on the display after switching on. If so, contact your local dealer.

Check that the SIM card is correctly installed, see "First start-up" on page 17.

## 3. Communicator interface does not activate or applications stop responding

Close the cover and open it again. If this does not help, close the cover and remove the battery. Replace the battery and open the cover again. Wait while the communicator performs a self-test and starts.

Try charging the communicator.

See also problem 4.

## 4. Internal memory or system errors

Sometimes, for example, removing the battery in mid-operation may cause errors in the file system of the communicator. If you receive internal memory or system error messages and/or reboot prompts, or if the device does not respond to commands normally, resetting the communicator helps you recover from most of these problems. Try the reset operations in the order they have been listed: if checking the file system does not help, try removing temporary files, or format the file system.

### To reset the communicator

- 1 Close the cover.
  - 2 Remove the memory card if inserted.
  - 3 Remove the battery.
  - 4 Place the connector end of the battery in the battery cavity, but do not press the other end in place yet. The connector end is the one with the four metal strips.
  - 5 Place the communicator on a flat surface with the phone display upwards. Do not let the battery slip from its place.
  - 6 Open the cover.
  - 7 Press and hold down the required key combination (see below) and simultaneously push the battery end of the communicator down, so that the battery clicks into place. Hold down the keys until you see progress messages or a confirmation prompt on the display.
  - 8 In some cases you must confirm the action by pressing a command button.
- After the reset, the communicator will reboot and start normally.

### To check the file system

Symptoms: The Memory application in the System application group shows too much (over 2 megabytes) or too little memory, even if you have just removed some documents, or the communicator applications crash when opening a document.

Key combination: Shift-Tab-left arrow

**Caution:** If there are problems in the file system, the corrupted files will be removed. If there are no problems, this operation does not affect any documents or settings.

### To remove temporary files

Symptoms: The communicator is in a reboot cycle or a note saying that an .ini file is corrupted is displayed.

Key combination: Shift-Tab-right arrow

**Caution:** All temporary files will be removed. The Document outbox will be cleared, the default application settings restored, but for example, the SMS

message centre number, Internet access point and Remote mailbox settings will be lost.

Stored documents will not be affected.

### To format the file system

Symptoms: The communicator is in a reboot cycle or does not boot up.

First, check that your battery is not empty.

Key combination: Shift-Tab-F

**Caution:** Formats the file system. All data you have entered will be lost. This operation will restore your communicator to the state it was in at the time of purchase.

Remember that backed up data can be restored in all cases.

If these measures do not help, contact your local dealer.

### 5. Cannot make or receive calls

Make sure that the phone is not off. Close the cover and switch on the phone.

If you get the message INVALID SIM CARD, your SIM cannot be used in the communicator. Contact you dealer or network operator.

Check the status of your call barrings and diverts, see "Telephone settings" on page 63.

The phone may be busy: data or fax is being sent or received, or the communicator is being used as a fax modem. Wait for the data/fax transmission to end, or drop the call by pressing the  key on the phone keypad.

### 6. Call quality is poor

Your location may not allow better call quality. This problem may occur especially in a moving car or train. Move to a location where the radio signal reception is better. See "Facts about cellular data transmission" on page 14.

Reception is usually better above ground level, outdoors and while stationary. Sometimes even moving the communicator slightly will improve reception. You can also try using the communicator in the handsfree mode, see "Handsfree mode" on page 59. Remember to turn the antenna to an upright position.

### 7. Cannot divert or bar voice, fax or data calls

You may have not subscribed to the service in question, or it is not supported by the network, or the message centre number and the number to which you want to divert your calls may be missing or incorrect.

Fax diverts and barrings are set in the settings of the Fax application. Data barring is set in the Internet settings. Data calls cannot be diverted.

## 8. Cannot select a contact

If you cannot select a contact in the Telephone, Fax, SMS or Mail directory, the contact card does not have a telephone number, fax number, wireless phone number or an e-mail address. Add the missing information to the contact card in the Contacts application.

## 9. Cannot send or receive faxes, short messages or mail

Make sure that you have subscribed to these network services.

The phone may be off, or the communicator is low on memory. See problem 16.

The number format you use may be invalid, or the called number has not answered within 10 tries, or you are calling to a wrong phone number.

The phone may be busy: data or fax is being sent or received, the communicator is being used as a fax modem. Wait for the data/fax transmission to end, or drop the call by pressing the  key on the phone keypad.

Fax/data barrings or fax diverts may be active. Fax barrings/diverts are set in the settings of the Fax application, data barrings are set in the Internet settings.

**Fax reception:** Your SIM card may not have a fax number.

**Mail reception:** Your SIM card may not have a phone number for data connections. Contact your service provider.

**Mail sending:** You have not subscribed to a remote mailbox service, or the mail server delivering your mail does not comply with the SMTP protocol. Contact your e-mail service provider. If you are using the *Upon request* sending option, mail must be sent in the Document outbox, see "To send mail" on page 90.

**Short message sending:** You have not subscribed to the Short Message Service or the message centre number is missing or incorrect. Contact your service provider.

The reason for failure may also depend on the network: the network does not support SMS, fax, or data/mail; the network is out of order or busy; the field strength is not adequate for sending.

## 10. Cannot establish a Terminal or Internet connection

The Internet, Mail, WWW, or Terminal settings and configurations may be missing or incorrect. Check your Internet access point configurations in the Internet main settings. Contact your Internet service provider for the correct settings. See "Internet settings" on page 84.

If you receive internal error messages, remove and replace the battery and try again. If the problem persists, see problem 4.

If you receive service provider error messages when connecting to your Remote mailbox, contact your remote mailbox service provider. Your Remote mailbox may contain corrupted mail messages or the mail server settings may be incorrect.

## 11. Infrared problems

The communicator may be connected to a PC, laptop, printer, digital camera, wireless phone or another communicator via the infrared link.

If you are using the PC Suite for Nokia 9110 Communicator program on your PC, or if you want to receive data from another communicator or a digital camera, you will have to start the Infrared activation application on your communicator before the connection is made. See "Infrared activation" on page 129.

If you are using the Nokia Communicator Server program on the PC, the infrared connection is established automatically when you use one of the PC connectivity applications of the communicator.

The PC to which you want to establish the connection must have an IrDA compatible infrared port; installed and activated IrDA drivers; and Microsoft Windows 95. For more information on IrDA drivers and their use in Windows 95, contact Microsoft.

For further information, see the Documentation section on the CD-ROM in the sales package of the communicator.

## 12. Printing problems

If you are using the infrared connection, the infrared port of the printer must be compatible to the IrDA standard. See "Document features" on page 34.

If you fail to establish an infrared connection, transfer the file to a PC and use the PC to print the document. Alternatively, you can fax the document to the nearest fax machine. See "To send faxes" on page 69.

Check that your printing settings are correct, see "System settings" on page 123.

You may be using an incorrect printer driver, see "Document features" on page 34.

## 13. PC connectivity problems

Make sure that the correct PC connectivity program is installed and running on your PC. See chapter 4 "PC connectivity" on page 39.

Check the cable or infrared connection used. If you use an infrared connection, the IR ports must be facing each other.

Check that you are using the correct COM port.

## 14. Fax modem problems

When you use the communicator as a fax modem, make sure that the communicator and the PC use the same baud rate. If you use the infrared connection, the baud rate is set automatically. If you use the cable connection, set the baud rate in the Fax modem settings. For the PC, the baud rate is set in the connectivity software of the PC.

If you use the cable connection, fully compatible operation with all PC fax and terminal software cannot be guaranteed. Consult your dealer. If you have problems with your PC fax software, use the infrared connection.

If you have problems establishing a data connection with the remote modem, try fixing the data transmission rate by using an AT command. Common AT commands based on the ETSI 07.07 standard and supported by the Nokia 9110 Communicator are listed in the *atcomm.txt* file on the diskette supplied with the communicator. For information on how to use the AT commands, consult the documentation of the telecommunication or fax application that you use on your PC.

## 15. Access code problems

The lock code is included in the sales package of the communicator. If you forget or lose the lock code, contact your communicator dealer.

If you forget or lose a PIN or PUK code, or if you have not received such a code, contact your network operator.

For information about Internet or Terminal passwords, contact your Internet service provider.

## 16. Low on memory

If you notice that the memory of your communicator is getting low, or you receive a warning note about insufficient memory, check the Memory application.

- 1 Press **Details** to see what kind of data takes up most memory. See "Memory" on page 128.
- 2 Make a backup of all important data.
- 3 Remove items which use a lot of memory, such as documents, received faxes, or old calendar data, either manually or with the Data removal application. See "Memory" on page 128. Or you can transfer the items to your memory card.

**Note:** Downloaded images, received faxes, and recordings may take up significant amounts of memory space.

## 17. Distorted characters in Terminal

If the data bits/stop bits/parity settings are different from those defined to the data service by the operator, characters may look distorted on the display.

## 18. ISDN connection

If you use an ISDN connection, go to the Internet settings and select *Internet access*. Select the access point you use or define a new one. In the *Advanced settings*, go to *Modem initialisation*. Enter the AT command AT+CBST=71 on the dotted line.



# 16. Care and maintenance

Your Nokia 9110 Communicator is a product of superior design and craftsmanship and should be treated with care. The suggestions below will help you to fulfil any warranty obligations and to enjoy this product for many years.

When using your communicator, battery, charger OR any accessory:

Keep it and all its parts and accessories out of small children's reach.

Keep it dry. Precipitation, humidity and liquids contain minerals that will corrode electronic circuits.

Do not use or store it in dusty, dirty areas. Its moving parts can be damaged.

Do not store it in hot areas. High temperatures can shorten the life of electronic devices, damage batteries, and warp or melt certain plastics.

Do not store it in cold areas. When the communicator warms up (to its normal temperature), moisture can form inside the communicator, which may damage electronic circuit boards.

Do not attempt to open it. Non-expert handling of the device may damage it.

Do not drop, knock or shake it. Rough handling can break internal circuit boards.

Do not use harsh chemicals, cleaning solvents, or strong detergents to clean it. Wipe it with a soft cloth slightly dampened in a mild soap-and-water solution.

Do not paint it. Paint can clog the device's moving parts and prevent proper operation.

Use only the supplied or an approved replacement antenna. Unauthorised antennas, modifications or attachments could damage the communicator and may violate regulations governing radio devices.

If the communicator, battery, charger or any accessory is not working properly, take it to your nearest qualified service facility. The personnel there will assist you and, if necessary, arrange for service.



# 17. Important safety information

## Traffic safety

Do not use a communicator while driving a vehicle. If using a communicator, park the vehicle first. Always secure the communicator in its holder; do not place the communicator on the passenger seat or where it can break loose in a collision or sudden stop.

The use of an alert device to operate a vehicle's lights or horn on public roads is not permitted.

Remember road safety always comes first!

## Operating environment

Remember to follow any special regulations in force in any area and always switch off the phone of your communicator whenever it is forbidden to use it, or when it may cause interference or danger.

When connecting the communicator or any accessory to another device, read its user's guide for detailed safety instructions. Do not connect incompatible products.

As with other mobile radio transmitting equipment, users are advised that for the satisfactory operation of the equipment and for the safety of personnel, it is recommended that the equipment should only be used in the normal operating position (held to your ear with the antenna pointing over your shoulder).

Do not point the infrared beam at anyone's eye or allow it to interfere with other infrared devices.

## Electronic devices

Most modern electronic equipment is shielded from radio frequency (RF) signals. However, certain electronic equipment may not be shielded against the RF signals from your communicator.

**Pacemakers:** Pacemaker manufacturers recommend that a minimum separation of 20 cm (6 inches) be maintained between a hand-held wireless phone and a pacemaker to avoid potential interference with the pacemaker. These recommendations are consistent with the independent research by and recommendations of Wireless Technology Research. Persons with pacemakers:

Should always keep the communicator more than 20 cm (6 inches) from their pacemaker when the phone is switched on;

Should not carry the communicator in a breast pocket;

Should use the ear opposite the pacemaker to minimise the potential for in-

terference.

If you have any reason to suspect that interference is taking place, switch off the phone of your communicator immediately.

**Hearing aids:** Some digital wireless phones may interfere with some hearing aids. In the event of such interference, you may want to consult your service provider.

**Other medical devices:** Operation of any radio transmitting equipment, including communicators, may interfere with the functionality of inadequately protected medical devices. Consult a physician or the manufacturer of the medical device to determine if they are adequately shielded from external RF energy or if you have any questions. Switch off the phone of your communicator in health care facilities when any regulations posted in these areas instruct you to do so. Hospitals or health care facilities may be using equipment that could be sensitive to external RF energy.

**Vehicles:** RF signals may affect improperly installed or inadequately shielded electronic systems in motor vehicles (e.g. electronic fuel injection systems, electronic anti-skid (anti-lock) braking systems, electronic speed control systems, air bag systems). Check with the manufacturer or its representative regarding your vehicle. You should also consult the manufacturer of any equipment that has been added to your vehicle.

**Posted facilities:** Switch off the phone of your communicator in any facility where posted notices so require.

### Potentially explosive atmospheres

Switch off the phone of your communicator when in any area with a potentially explosive atmosphere and obey all signs and instructions. Sparks in such areas could cause an explosion or fire resulting in bodily injury or even death.

Users are advised to switch off the phone when at a refuelling point (service station). Users are reminded of the need to observe restrictions on the use of radio equipment in fuel depots (fuel storage and distribution areas), chemical plants or where blasting operations are in progress.

Areas with a potentially explosive atmosphere are often but not always clearly marked. They include below deck on boats; chemical transfer or storage facilities; vehicles using liquified petroleum gas (such as propane or butane); areas where the air contains chemicals or particles, such as grain, dust or metal powders; and any other area where you would normally be advised to turn off your vehicle engine.

### Vehicles

Only qualified personnel should service the communicator, or install the communicator in a vehicle. Faulty installation or service may be dangerous and may invalidate any warranty which may apply to the unit.

Check regularly that all wireless phone equipment in your vehicle is mounted and operating properly.

Do not store or carry flammable liquids, gases or explosive materials in the same compartment as the communicator, its parts or accessories.

For vehicles equipped with an air bag, remember that an air bag inflates with great force. Do not place objects, including both installed or portable wireless equipment in the area over the air bag or in the air bag deployment area. If in-vehicle wireless equipment is improperly installed and the air bag inflates, serious injury could result.

Switch off the phone of your communicator before boarding an aircraft. The use of wireless telephones in an aircraft may be dangerous to the operation of the aircraft, disrupt the wireless telephone network and may be illegal.

Failure to observe these instructions may lead to suspension or denial of telephone services to the offender, or legal action or both.



## Emergency calls

### IMPORTANT!

The Nokia 9110 Communicator, like any wireless phone, operates using radio signals, wireless and landline networks as well as user-programmed functions which cannot guarantee connection in all conditions. Therefore you should never rely solely upon any wireless phone for essential communications (e.g. medical emergencies).

Remember, to make or receive any calls the phone must be switched on and in a service area with adequate signal strength. Emergency calls may not be possible on all wireless phone networks or when certain network services and/or phone features are in use. Check with local service providers.

### To make an emergency call

- 1 If the device cover is open, close the cover.
- 2 If the phone is not on, switch it on by pressing the  key. Some networks may require that a valid SIM card is properly inserted in the communicator.
- 3 Press and hold the  key for several seconds to ready the phone for calls, and to end possible active data or fax calls.
- 4 Key in the emergency number for your present location (e.g. 112 or other official emergency number). Emergency numbers vary by location.
- 5 Press the  key.

If certain features are in use (call barring, fixed dialling, closed user group, system lock, keypad lock, etc.), you may first need to turn those features off before you can make an emergency call. Consult this document and your local cellular service provider.

When making an emergency call, remember to give all the necessary information as accurately as possible. Remember that your communicator may be the only means of communication at the scene of an accident - do not cut off the call until given permission to do so.

## To use this manual

The wireless phone described in this manual is approved for use in the GSM networks.

A number of features included in this manual are called network services. They are special services provided by wireless service providers. Before you can take advantage of any of these network services, you must subscribe to the service(s) you require from your home service provider and obtain instructions for their use. You can then activate these functions as described in this manual. The manual activation commands for various services are not presented in this manual (e.g., using the \* and # characters for activating or deactivating services). The Nokia 9110 Communicator, nevertheless, is capable of handling commands given in that form. For these commands, please consult with your service providers.

**WARNING! This apparatus is intended for use when supplied with power from a Lithium-ion battery and chargers ACP-9E, ACP-9X and ACP-9A. Other usage will invalidate any approval given to this apparatus and may be dangerous.**

Use only batteries, chargers, and accessories approved by the communicator manufacturer for use with this particular communicator model. The use of any other types will invalidate any approval or warranty applying to the communicator, and may be dangerous.

For availability of approved accessories, please check with your dealer.

When you disconnect the power cord of any accessory, grasp and pull the plug, not the cord.

# Glossary

## A **AT commands**

Operations of a fax modem can be controlled by AT commands. These commands give the advanced user an opportunity to control all the features of the modem. A list of common AT commands based on the ETSI 07.07 standard and supported by the Nokia 9110 Communicator are available in the *atcomm.txt* file on the diskette included in the sales package of your communicator.

## B **Barring password**

The barring password is a 4-digit code needed to change fax and voice call barrings, see "Telephone settings" on page 63. The password is not located in your communicator or SIM card, but in the network. You obtain the password from your network operator when you subscribe to the call barring service.

## C **Cookies**

Cookies are little pieces of information, given by the server to you, to store information about your visits to a web site. When you accept cookies, the server is able to evaluate your use of the web site; what you are interested in, what you want to read, etc.

## D **Domain name and Host name**

The terms "domain name" and "host name" are sometimes, slightly inaccurately, used as synonyms. In a fully qualified domain name, e.g. *www.forum.nokia.com*, the first part of the name is the name of the host, and the following parts are names of domains to which the host belongs. Each host name corresponds to a certain IP address. Host names are used because they are easier to remember than IP addresses.

### **DTMF (Dual Tone Multi-Frequency) tones**

DTMF tones are the tones you hear when you press the number keys on the phone keypad. DTMF tones allow you to communicate with voice mailboxes, computerised telephony systems, etc.

## H **Hotspot**

A WWW page may contain hotspots, such as selection lists, text entry fields, and reset/submit buttons, which enable you to input information into the World Wide Web.

**HTML (Hypertext Markup Language)**

A language used to define the appearance and content of WWW documents.

**HTTP (Hypertext Transfer Protocol)**

A document transfer protocol used in the WWW.

**Hyperlink**

Hyperlinks are used to move from one WWW page to another.

**I IAP (Internet Access Point)**

The point where your communicator connects to the Internet by way of a data call. An Internet access point can be provided, for example, by a commercial Internet service provider or by your own company.

**Images, inline, external**

Images within a fetched WWW page are inline images. Larger images are often placed as external images and have to be viewed separately.

**IMAP4 (Internet Mail Access Protocol, version 4)**

A protocol used for accessing your Remote mailbox.

**IP (Internet Protocol) address**

All computers and other devices connected to the Internet using the Internet Protocol have their own individual addresses. The address consists of four numbers separated by points: for example, 131.227.21.167.

**L Lock code**

The lock code is a five-digit code needed to lock and unlock the communicator. The lock code is also required when you change certain settings. You will find the lock code on a sticker in the sales package of your communicator. Keep it secret and in a safe place, separate from the communicator.

**M MCN (Micro-Cellular Network) technology**

Microcells are used for increasing the capacity of wireless networks in urban areas.

**MIME (Multipurpose Internet Mail Extensions)**

A standard Internet format which permits including multiple mail objects in a single message. The mail objects can be, for example, formatted multifont text messages and non-textual elements, such as images and audio fragments.



**P PIN (Personal Identity Number) code**

The PIN code protects your phone from unauthorised use. The PIN code is supplied with the SIM card. If the PIN code request is set on, the code is required each time the phone is switched on. The PIN code must be 4 to 8 digits long.

**PIN2 code**

The PIN2 code is supplied with some SIM cards. The PIN2 code is required to access certain functions supported by the SIM card. The length of the PIN2 code is 4 to 8 digits.

**Plug-in**

A plug-in is add-on software that can be downloaded from the WWW. The communicator uses plug-ins to display a document that the WWW application itself cannot show.

**POP3 (Post Office Protocol, version 3)**

A common mail protocol that can be used for accessing the Remote mailbox.

**PPP (Point to Point Protocol)**

A common networking software protocol which enables any computer with a modem and a phone line to connect directly to the Internet.

**Protocol**

A formal set of rules that govern how data is transferred between two devices.

**Proxy**

In some networks, the connection between the WWW and the site you want to connect to is blocked by a firewall. The firewall protects the network from unauthorised external access. A proxy is an intermediary program that enables access through the firewall. A proxy can also serve as a network cache to speed up the fetching process.

**PUK (PIN Unblocking Key) code**

The PUK is an 8-digit code supplied with the SIM card. The code is required when you want to change a disabled PIN code. If you enter an incorrect PUK code ten times in succession, the SIM card is rejected and you cannot make or receive any calls, except emergency calls. When the SIM is rejected, you will need a new SIM card.

You cannot change the PUK code. If you lose the code, contact your network operator.

**PUK2 code**

The PUK2 code is supplied with some SIM cards. The code is required when you want to change a disabled PIN2 code. If you enter an incorrect PUK2 code ten times in succession, you will not be able to access the functions which require the PIN2 code. To use these functions again, you will need to obtain a new SIM card from your network operator.

You cannot change the PUK2 code.

**S SIM (Subscriber Identity Module) card**

The SIM card contains all the information the cellular network needs to identify the network user. The SIM card also contains security-related information.

**SMTP (Simple Mail Transport Protocol)**

An Internet protocol governing the transfer of electronic mail.

**SSL (Secure Socket Layer)**

A security protocol that prevents eavesdropping, tampering, or message forgery over the Internet. Documents using SSL are identified with the prefix HTTPS.

**T TCP Port**

Identifies the data port of the destination computer.

**TCP/IP (Transmission Control Protocol/Internet Protocol)**

A protocol that governs data communication in the Internet and in the TCP/IP networks.

**U URL (Uniform Resource Locator)**

Link information required by the WWW to connect to a given WWW host computer. The URL usually starts with *http://* followed by *www*. For example, the Nokia Wireless Data Forum home page can be found at <http://www.forum.nokia.com>. URLs are often referred to with phrases like "Home page location," "Site location," "can be found at..."

**V Voice mailbox**

A voice mailbox is a network service or a personal answering machine where people can leave you voice messages.

# Index

## A

- Alarms
  - Calendar 121
  - Clock 137
- Alternate phone line service 158
- AT commands 131, 175
- Autolock 127

## B

- Backlight
  - Settings 124
  - Turning on 31
- Barring password 128
- Battery 27
  - Charging 27
- Booking events 119
  - Cancelling and changing bookings 120
- Business cards 79

## C

- Cable connection 40
- Cache 95
  - Emptying 101
- Calendar
  - Adding events 117
  - Alarms 121
  - Booking password 119
  - Cancelling and changing bookings 120
  - Memos 118
  - Receiving bookings 120
  - Sending bookings 119
- Caller groups 64
- Calls
  - Alternate lines 158
  - Alternating calls 62
  - Answering 58, 148
  - Answering a waiting call 62

- Anykey answer 157
- Automatic redialling 157
- Barring 66, 159
- Closed user group 160
- Conference call 61, 148
- Diverting 65, 161
- Fixed dialling 160
- Making a call 57, 147
- Making a new call 61, 148
- Making an emergency call 173
- Poor call quality 14, 165
- Putting on hold 148
- Recording conversation 59, 148, 162
- Showing costs 58, 155
- Showing duration 155
- Switching between calls 60
- Transferring 62, 149
- Waiting call 66, 157
- Chr key 111
- Cities
  - Changing home city 139
  - Editing and adding 138
  - Selecting destination city 138
- Cleaning the communicator 169
- Clock settings 139
- Codes
  - Lock code 128
  - PIN code 127
  - PIN2 code 127
  - PUK code 177
  - PUK2 code 178
- Composing tunes 139
- Conference call 61
- Contact card
  - Adding fields 51
  - Attaching an image 52
  - Creating 51
  - Customising fields 52
  - Setting an individual ringing tone 52
  - Template 50

- Contact groups
  - Creating 54
- Contrast control 125
- Costs 58

## D

- Date format 125
- Delivery reports 81
- Diverting calls 65
- Document outbox 36
- Documents
  - Printing 110
  - Reading 109
  - Read-only documents 112
  - Sending 112
  - Transferring via IR 110
  - Writing 109
- Downloaded files
  - Installing 101
  - Opening 112
- DTMF tones
  - Sending 62, 150
  - Special characters 53
  - Storing 53

## E

- Emergency calls 173

## F

- Fax
  - Adding a logo 73
  - Adding a signature 73
  - Barring 73
  - Cover page settings 72
  - Diverting 73
  - Forwarding 69
  - Printing 72
  - Receiving 71
  - Sending 70
  - Setting sending time 73
  - Writing 69
- Fixed dialling 160
- Flight profile

Setting on 67

Folders

Creating 110

Removing 110

Font 111

Formatting the file system 165

## G

General log 55

## H

Handsfree mode 59

Help

Application help 32

General help 32

Phone 151

## I

Images

Contact images 52

Transferring 129

WWW images 101

Import/Export

Calendar 45

Contacts 45

Indicators 22

Individual log 55

Info service

Reading 153

Settings 81, 154

Infrared connection

Connecting to a communicator 129

Connecting to a PC 40

Connecting to a printer 35

Internet

Access requirements 83

Autodisconnect time 85

Data call barring 85

Defining an access point 84

## K

Keyboard 24

Keypad 145

**L**

- Lock code 128
- Locking
  - Communicator 125, 161
  - Keypad 151
- Logs 55

**M**

- Mail
  - Adding a signature 90
  - Adding attachments 91
  - Fetching 92
  - Fetching attachments 89
  - Font 88
  - Forwarding 94
  - Opening attachments 93
  - Printing 94
  - Reading 93
  - Remote mailbox 92
  - Removing messages 93
  - Replying 94
  - Sending 90
  - Sending upon request 91
  - Timed fetching 90
  - Writing 90
- Margins 111
- Memory
  - Cache 95
  - Details 128
  - SIM memory 54
- Memory card 32
  - Inserting 32
- Menu button 31
- Message centre number 80
- Messages
  - Info messages 81, 153
  - Short messages 75, 153
- Multiselection 33

**N**

- Network
  - Selecting 159

- Settings 65
- Nokia CareLine contact card 49, 115
- Nokia Communicator Server
  - Installing 46
- Nokia Wireless Data Forum 163
- Notes
  - Sending 112
  - Writing 109

**O**

- Own number sending 65, 158

**P**

- Passwords
  - Barring password 128
  - Booking password 119
  - Internet password 86
  - Mail password 89
  - WWW password 97, 99
- PC connectivity
  - Cable connection 40
  - Infrared connection 40
- PC Suite for Nokia 9110 Communicator
  - Installing 40
- PIN code 127
- PIN2 code 127
- Printing 35
  - Cable connection 36
  - Documents 110
  - Faxes 72
  - Infrared connection 35
  - Mail messages 94
  - Settings 124
  - SMS messages 78
- Profiles
  - Modifying 63, 157
  - Setting on 156
- PUK code 177
- PUK2 code 178

**R**

- Read-only documents
  - Opening 112



- Received communication note 37
- Receiving
  - Fax 71
  - Mail 92
  - SMS 77
- Recorder
  - Playing a recording 142, 162
  - Recording 142, 162
- Remote mailbox 87, 92
- Resetting the communicator 164
- Ringing tones
  - Alternate ringing tone 123
  - Composing 139
  - Recording 142
  - Selecting 123
  - Sending 141
  - Setting individual tones 52
  - Settings 64

## S

- Safety information
  - Electronic devices 171
  - Operating environment 171
  - Traffic safety 171
  - Vehicles 172
- Screen blanker 125
- Search field 21, 49
- Selection frame 20
- Sending
  - Documents 112
  - DTMF tones 62
  - Mail 90
  - SMS 76
- Service cards 78
- Shortcuts 34
- Signal strength 15
  - Indicator 23, 147
- SIM card
  - Installing 17, 32
  - Viewing contents 54
- SMS

- Forwarding 78
- Receiving 77, 153
- Replying 78
- Sending 76
- Setting message centre number 80
- Writing 76

- Special characters 111
- Speed dialling
  - Settings 53
  - Using 149
- Standard messages 78

## T

- Telnet
  - Defining connections 105
  - Special keys 106
- Terminal
  - Defining connections 103
  - Special keys 104
- Text Web
  - Defining services 107
  - Fetching information 107
- Time format 125
- Tones
  - Adding ringing tones 110
  - Application tones 124
  - Composing 139
  - Notification tone 124
  - Recording 142
  - Ringing tones 64, 123
  - Sending 141
  - Silencing 63
- Transferring
  - Calls 62
  - Data from older communicator models 37
  - Data from other handheld devices 51
  - Text (Telnet, Terminal) 104

## U

- Unit of measure 125
- Unlocking
  - Communicator 126, 161
  - Keypad 151

## V

- Voice mailbox
  - Calling 67, 146, 150, 154
  - Setting number 67, 154
- Volume
  - Adjusting loudspeaker 59
  - Communicator key click 64
  - Phone key click 64
  - Ringing tone 64

## W

- Welcome note 158
- World time 138
- World Wide Web
  - Access requirements 95
  - Adding bookmarks 96
  - Copying text 100
  - Creating a bookmark folder 97
  - Downloading software 101
  - Fetching a page 96
  - Following a hyperlink 100
  - Navigation commands 100
  - Saving a page 101
  - Saving the HTML format 97
  - Timed fetching 98
  - Viewing images 101

## Z

- Zoom button 31