

Electronic user's guide released subject to "Nokia User's Guides Terms and Conditions, 7th June, 1998"

User's guide



9355124
Issue 1

DECLARATION OF CONFORMITY

We, NOKIA CORPORATION declare under our sole responsibility that the product NPM-6 is in conformity with the provision of the following Council Directive: 1999/5/EC. A copy of the Declaration of Conformity can be found from http://www.nokia.com/phones/declaration_of_conformity/

Copyright © 2002-2003 Nokia. All rights reserved.

Reproduction, transfer, distribution or storage of part or all of the contents in this document in any form without the prior written permission of Nokia is prohibited.

Nokia, Nokia Connecting People and Pop-Port are trademarks or registered trademarks of Nokia Corporation. Other product and company names mentioned herein may be trademarks or tradenames of their respective owners.

Nokia tune is a sound mark of Nokia Corporation.

US Patent No 5818437 and other pending patents. T9 text input software Copyright (C) 1997-2003. Tegic Communications, Inc. All rights reserved.



Includes RSA BSAFE cryptographic or security protocol software from RSA Security.



Java is a trademark of Sun Microsystems, Inc.

Nokia operates a policy of continuous development. Nokia reserves the right to make changes and improvements to any of the products described in this document without prior notice.

Under no circumstances shall Nokia be responsible for any loss of data or income or any special, incidental, consequential or indirect damages howsoever caused.

The contents of this document are provided "as is". Except as required by applicable law, no warranties of any kind, either express or implied, including, but not limited to, the implied warranties of merchantability and fitness for a particular purpose, are made in relation to the accuracy, reliability or contents of this document. Nokia reserves the right to revise this document or withdraw it at any time without prior notice

The availability of particular products may vary by region. Please check with the Nokia dealer nearest to you.

9355124 /issue 1

Contents

FOR YOUR SAFETY	11
General information.....	14
Stickers in the sales package	14
Access codes	14
Shared memory	15
Typographics used in this guide.....	16
1. Your phone.....	17
Improved durability.....	17
Using your phone in wet and damp conditions.....	18
Keys	19
Connectors.....	20
Standby mode.....	21
Flashlight.....	21
List of indicators in standby mode.....	21
2. Getting started	24
Installing the SIM card and the battery.....	24
Changing the shells	26
Charging the battery	27
Switching the phone on and off	27
Strap for carrying and fastening.....	28
Keypad lock (Keyguard)	28
3. Call functions	30
Making a call	30



Making a conference call	31
Answering or rejecting an incoming call	32
Call waiting.....	32
Options during a call	32
Loudspeaker	33
4. Phone book (Names)	34
Selecting the phone book settings	34
Saving names and phone numbers (Add name)	35
Saving multiple numbers and text items per name.....	35
Searching for a name in the phone book	36
Editing a name, number or text item	37
Erasing names and numbers.....	37
Copying phone books	37
Sending and receiving a business card	38
Speed dials.....	39
Info and service numbers	39
My numbers	40
Caller groups.....	40
5. Using the menu	41
Accessing a menu function	41
By scrolling	41
By shortcut.....	42
List of menu functions.....	43
6. Menu functions	51
Messages (Menu 1)	51
Text messages	52
Using traditional text input.....	52



Setting predictive text input on or off.....	52
Using predictive text input.....	53
Writing compound words.....	53
Writing and sending messages.....	54
Options for sending a message.....	54
Writing and sending e-mail.....	54
Reading and replying to a message or an e-mail.....	55
Inbox and outbox folders.....	57
Templates.....	57
Archive folder and my folders.....	58
Multimedia messages.....	58
Writing and sending a multimedia message.....	59
Reading and replying to a multimedia message.....	60
Inbox, Outbox, Saved and Sent items folders.....	61
Erasing messages.....	61
Chat.....	62
Voice messages.....	62
Info messages.....	63
Message settings.....	63
Settings for text and e-mail messages.....	63
Overwrite settings.....	65
Settings for multimedia messages.....	65
Font size setting.....	66
Service commands.....	67
Call register (Menu 2).....	67
Recent calls lists.....	67
Call counters and call timers.....	68
Profiles (Menu 3).....	69



Settings (Menu 4).....	70
Time and date settings.....	70
Clock.....	70
Date.....	70
Auto update of date and time.....	71
Call settings.....	71
Automatic volume control.....	71
Call divert.....	72
Anykey answer.....	73
Automatic redial.....	73
Speed dialling.....	73
Call waiting.....	73
Summary after call.....	73
Send my caller identity.....	73
Line for outgoing calls.....	74
Phone settings.....	74
Language.....	74
Automatic keyguard.....	74
Cell info display.....	75
Welcome note.....	75
Network selection.....	76
Confirm SIM service actions.....	76
Help text activation.....	76
Start-up tone.....	76
Display settings.....	76
Wallpaper.....	76
Colour schemes.....	77
Operator logo.....	77



Screen saver	78
Display brightness	78
Tone settings	78
Accessory settings.....	79
Security settings.....	80
Restore factory settings	81
Alarm clock (Menu 5).....	81
Radio (Menu 6).....	82
Tuning a radio channel.....	83
Using the radio	83
Gallery (Menu 7).....	85
Organiser (Menu 8).....	86
Calendar.....	86
Making a calendar note.....	87
When the phone alarms for a note	88
To-do list	88
Games (Menu 9).....	89
Launching a game.....	89
Game services	90
Memory status for games.....	90
Game settings	90
Applications (Menu 10)	91
Launching an application	91
Other options available for an application or application set.....	92
Downloading an application.....	92
Memory status for applications.....	94
Extras (Menu 11)	94
Calculator	94



Making a currency conversion.....	95
Countdown timer	95
Normal timing	95
Adding a new interval timer.....	96
Starting interval timer	96
Stopwatch	97
Split timing.....	97
Lap timing.....	98
Viewing times	98
Deleting times	98
Calorie counter	98
Saving personal data	99
Selecting an activity.....	99
Editing and deleting activities.....	99
Thermometer.....	100
Sound meter	100
Connectivity (Menu 12).....	101
Infrared	101
GPRS	102
GPRS connection	102
GPRS modem settings.....	103
WAP services (Menu 13).....	103
Basic steps for accessing and using WAP services.....	104
Setting up the phone for a WAP service	104
Saving the service settings received as a text message.....	105
Keying in the service settings manually	105
Settings when GSM data is the selected data bearer.....	106
Settings when GPRS is the selected data bearer	107



Making a connection to a WAP service.....	107
Browsing the pages of a WAP service.....	108
Using the phone keys while browsing.....	109
Options while browsing.....	109
Direct calling.....	110
Ending a WAP connection.....	110
Appearance settings of WAP browser.....	110
Cookie settings.....	111
Bookmarks.....	111
Receiving a bookmark.....	112
Service inbox.....	112
To set the phone to receive service messages.....	113
The cache memory.....	113
Authority certificates.....	114
Viewing the list of authority certificates.....	114
Security indicator.....	114
SIM services (Menu 14).....	115
7. Battery information.....	116
Charging and Discharging.....	116
CARE AND MAINTENANCE.....	118
IMPORTANT SAFETY INFORMATION.....	119



FOR YOUR SAFETY

Read these simple guidelines. Breaking the rules may be dangerous or illegal. Further detailed information is given in this manual.



Do not switch the phone on when wireless phone use is prohibited or when it may cause interference or danger.



ROAD SAFETY COMES FIRST

Don't use a hand-held phone while driving.



INTERFERENCE

All wireless phones may get interference, which could affect performance.



SWITCH OFF IN HOSPITALS

Follow any regulations or rules. Switch the phone off near medical equipment.



SWITCH OFF IN AIRCRAFT

Wireless devices can cause interference in aircraft.



SWITCH OFF WHEN REFUELLING

Don't use the phone at a refuelling point. Don't use near fuel or chemicals.



SWITCH OFF NEAR BLASTING

Don't use the phone where blasting is in progress. Observe restrictions, and follow any regulations or rules.



USE SENSIBLY

Use only in the normal position. Don't touch the antenna unnecessarily.



QUALIFIED SERVICE

Only qualified personnel may install or repair phone equipment.





ACCESSORIES AND BATTERIES

Use only approved accessories and batteries. Do not connect incompatible products.



CONNECTING TO OTHER DEVICES

When connecting to any other device, read its user's guide for detailed safety instructions. Do not connect incompatible products.





BACKUP COPIES

Remember to make backup copies of all important data.



CALLING

Ensure the phone is switched on and in service. Enter the phone number, including the area code, then press . To end a call, press . To answer a call, press .

■ Network Services

The wireless phone described in this guide is approved for use on the EGSM 900, GSM 1800 and GSM 1900 network.

Triband is a network dependent feature. Check with your local service provider if you can subscribe to and use this feature.

A number of features included in this guide are called Network Services. These are special services that you arrange through your wireless service provider. Before you can take advantage of any of these Network Services, you must subscribe to them through your service provider and obtain instructions for their use from your service provider.



Note: Some networks may not support all language-dependent characters and/or services.



■ About accessories

Check the model number of any charger before use with this device. This device is intended for use when supplied with power from ACP-7, ACP-8, ACP-12, LCH-9 and LCH-12.



Warning: Use only batteries, chargers and accessories approved by the phone manufacturer for use with this particular phone model. The use of any other types may invalidate any approval or warranty applying to the phone, and may be dangerous.

For availability of approved accessories, please check with your dealer.

When you disconnect the power cord of any accessory, grasp and pull the plug, not the cord.



General information

■ Stickers in the sales package

The stickers contain important information for services and customer support purposes.

Attach the **B** sticker to your warranty card.

Attach the **A** sticker to the Nokia Club Invitation Card if supplied in the sales package.

■ Access codes

For specific settings of Access codes, see [Security settings](#) on page 80.

- **Security code (5 to 10 digits):** The security code protects your phone against unauthorised use, and is supplied with the phone. The preset code is 12345. Change the code, and keep the new code secret and in a safe place separate from your phone.
- **PIN code and PIN2 code (4 to 8 digits):** The PIN (Personal Identification Number) code protects your SIM card against unauthorised use. The PIN code is usually supplied with the SIM card.

The PIN2 code may be supplied with the SIM card and is required to access some functions, such as charging unit counters.



If you key in an incorrect PIN code three times in succession, the phone may display *PIN code blocked* and ask you to key in the PUK code. Contact your service provider to get the PUK code.

- **PUK and PUK2 codes (8 digits):** The PUK (Personal Unblocking Key) code is required to change a blocked PIN code. The PUK2 code is required to change a blocked PIN2 code.

If the codes are not supplied with the SIM card, contact your local service provider for the codes.

- **Barring password (4 digits):** The barring password is needed when using the *Call barring service*, see [Security settings](#) on page 80. You can obtain the password from your service provider.



■ Shared memory

The following features in this phone may share memory: phone book, text and multimedia messages, images and ringing tones in gallery, calendar, to-do notes, and Java games and applications. Using any such features may reduce the memory available for any features sharing memory. This is especially true with heavy use of any of the features (although some of the features may have a certain amount of memory specially allotted to them in addition to the amount of memory shared with other features). For example, saving many images, java applications etc. may take all of the shared memory and your phone may display a message that the memory is full. In this case, delete some of the information or entries stored in the shared memory features before continuing.



■ Typographics used in this guide

The display texts which appear on the phone's display are indicated in italic typeface, for example *Calling*.

The display texts related to the selection keys  and  are indicated in bold typeface, for example **Menu**.



1. Your phone

■ Improved durability



The Nokia 5100 has been designed for an active lifestyle. It is a phone with enduring quality and reliability. It has an improved protection against water splashes, dust, and bumps. The rubbery surface provides a firm and reliable grip and convenience.

The top and bottom shells provide improved protection against water splashes and dust. Also the inner module has resistance to splashes and dust when the shells and key mat are mounted. There are membranes and gaskets to give protection for inner parts.

The phone has improved durability to protect against accidental bumps. The bottom flap gives extra protection for the connectors against bumps and dirt.

The Nokia 5100 phone also has several features to accompany you in your activities, like:



- Loudspeaker (p. 33), Radio (p. 82), Flashlight (p. 21), Calorie counter (p. 98), Thermometer (p. 100), Countdown timer (p. 95), Stopwatch (p. 97), Automatic volume control (p. 71) and Sound meter (p. 100)
- downloadable personal games and applications via Java™ technology (p. 91), Multimedia messages (p. 58), WAP services (p. 103) and Polyphonic (MIDI) tones (p. 58).

■ Using your phone in wet and damp conditions



- You can use your phone in damp environments and outdoors even in the rain.
- Never immerse the phone in water.
- If water gets inside the phone shells, let the inner module and shells dry out or wipe them dry with a lint-free cloth.
- Always be sure that the phone is completely dry when you open the battery cover: SIM card, battery and inner parts are not protected against water.
- Always be sure that the battery cover is dry and clean and that it is properly closed.
- Always remember that the accessories do not meet the same durability or water resistance specifications as the phone itself.
- Never charge the phone when the bottom connectors are wet or damp.
- Never use a damp phone with accessories that have an electrical functionality.
- Always close the bottom flap properly after using any accessories.



■ Keys





1. **Power key**  switches the phone on and off.

With keypad locked, pressing the power key briefly turns the phone's display lights on for a short time.





2. **Volume keys**  , 

Keys for adjusting the earpiece, headset and loudspeaker volume.

3. **4-way scroll keys**

, ,  and  enable scrolling through names, phone numbers, menus or settings.

If pressed in the standby mode:



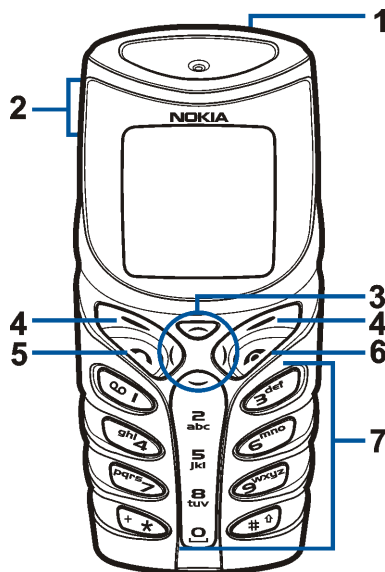



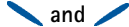



-  activates and deactivates the flashlight.
-  opens the list of phone book names.
-  opens the message creation view.
-  opens the calendar view.



4. Selection keys



Perform the function indicated by the text immediately above them, for example, **Menu** and **Names** in standby mode.

- 5.  dials a phone number, and answers a call. In standby mode it shows the list of most recently called numbers.
- 6.  ends an active call. **Exits from any function.**
- 7.  -  enter numbers and characters.
  can be used for speed dialling predefined phone numbers.
 dials the voice mailbox number
  and  are used for various purposes in different functions.

■ Connectors

- 1. Charger connector
- 2. Pop-Port™ connector for headsets and the data cable, for example.
- 3. Infrared (IR) port

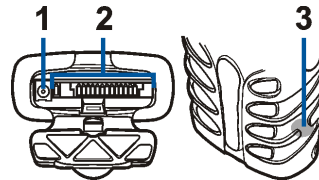

The bottom connectors are protected with a rubber flap. Keep the rubber flap closed if there are no accessories connected. Never use the rubber flap for carrying your phone.



■ Standby mode

The indicators below are shown when the phone is ready for use, with no characters entered. This screen is called standby mode.

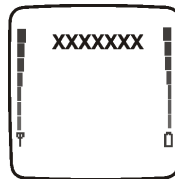

XXXX Indicates in which cellular network the phone is currently used.



Shows the signal strength of the cellular network at your current location. The higher the bar, the stronger the signal.







Shows the battery charge level. The higher the bar, the more power in the battery.

Flashlight











There is a flashlight in your phone. You can activate it in standby mode when the keypad is not locked.

To activate the flashlight









- press and hold . To switch it off, release .
- press  twice quickly. The flashlight is now continuously on. To switch it off again, press  once.



List of indicators in standby mode

-  You have received one or several text or picture messages. See [Reading and replying to a message or an e-mail](#) on page 60.
-  You have received one or several multimedia messages. See [Reading and replying to a multimedia message](#) on page 60.
-  You have received one or several voice messages. See [Voice messages](#) on page 62.
-  The phone's keypad is locked. See [Automatic keyguard](#) on page 74.
-  The phone does not ring at an incoming call or text message when *Incoming call alert* is set to *Off* and *Message alert tone* is set to *Off*. See [Tone settings](#) on page 78.
-  The alarm clock is set to *On*. See [Alarm clock \(Menu 5\)](#) on page 81.
-  The countdown timer is running. See [Countdown timer](#) on page 95.
-  The stopwatch timing is running in the background. See [Stopwatch](#) on page 97.
-  A GPRS dial-up connection is established, refer to [GPRS modem settings](#) on page 103.
-  There is an incoming or outgoing call during a GPRS dial-up connection. The GPRS connection is suspended.
-  Infrared connection indicator, see [Infrared](#) on page 101.



-  All your calls are diverted to another number, *Divert all voice calls*. If you have two phone lines, the divert indicator for the first line is  and for the second line . See [Call divert](#) on page 72.
- 1** or **2** If you have two phone lines, indicates the selected phone line. See [Line for outgoing calls](#) on page 74.
-  Loudspeaker is active, see [Loudspeaker](#) on page 33.
-  Calls are limited to a closed user group. See [Security settings](#) on page 80.
-  The timed profile is selected. See [Profiles \(Menu 3\)](#) on page 69.
- , or 
Headset or loopset accessory is connected to the phone.



2. Getting started

■ Installing the SIM card and the battery

Keep all miniature SIM cards out of the reach of small children.

- The SIM card and its contacts can easily be damaged by scratches or bending, so be careful when handling, inserting or removing the card.
- Before installing the SIM card, always make sure that the phone is switched off and then remove the battery.

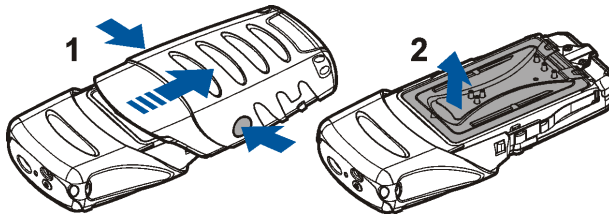

1. With the back of the phone facing you, press the bottom shell firmly from sides and remove it by sliding it downwards.
2. Lift up the battery cover.
3. Remove the battery if there.



4. Release the SIM card holder by pulling it downwards.
5. Insert your SIM card into the SIM card holder and ensure that the bevelled corner is on the top left and the golden contact area is facing downwards.
6. Close the SIM card holder.

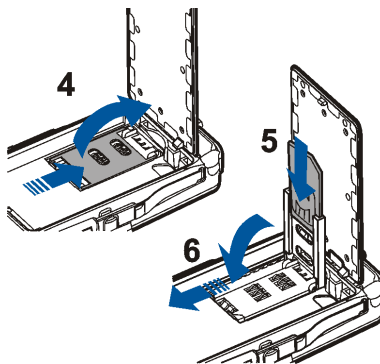

7. Replace the battery.
8. Attach the battery cover back on.
9. Slide the bottom shell back on until it locks into its place. See the step 5 in [Changing the shells](#) for reference.

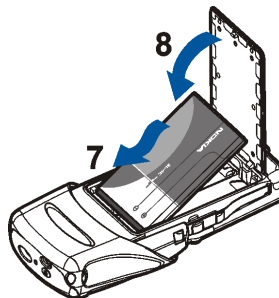

■ Changing the shells

Before changing the cover, always switch off the power and disconnect the phone from the charger or any other device. Always store and use the phone with the covers attached.

1. Remove the bottom shell of the phone, see for details the step 1 in [Installing the SIM card and the battery](#) on page 24.
2. Detach the top shell by pressing the locking springs on sides and then sliding the top shell upwards.
3. Replace the new top shell by sliding it over the phone's display.
4. Attach the key mat to the bottom shell.

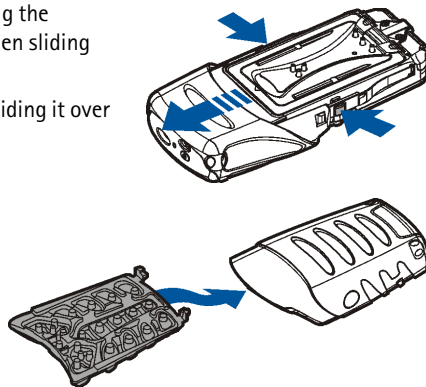

5. With the back of the bottom shell facing you slide the new bottom shell with key mat into its place.

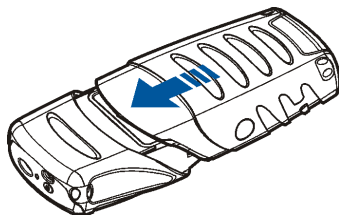

■ Charging the battery

1. Lift up the flap protecting the bottom connectors of your phone and connect the lead from the charger to the socket on the bottom of your phone. See [Connectors](#) on page 20.
2. Connect the charger to an AC wall outlet.

The text *Charging* is displayed briefly if the phone is switched on. If the battery is completely flat, it may take a few minutes before the charging indicator appears on the display or any calls can be made.

You can use the phone while the charger is connected. The charging time depends on the charger and the battery used.

■ Switching the phone on and off

Press and hold the power key  on the top of your phone.

If the phone asks for a PIN code or for a security code

- Key in the PIN code or security code, which are displayed as asterisks *****, and press **OK**.



See also [Access codes](#) on page 14.



Warning: Do not switch the phone on when wireless phone use is prohibited or when it may cause interference or danger.

TIPS ON EFFICIENT OPERATION: Your phone has a built-in antenna. As with any other radio transmitting device, do not touch the antenna unnecessarily when the phone is switched on. Contact with the antenna affects call quality and may cause the phone to operate at a higher power level than otherwise needed. Not touching the antenna area during a phone call optimises the antenna performance and the talktime of your phone.

■ Strap for carrying and fastening

- Insert the narrower plastic strap holders one by one to the strap holes at the bottom of the phone (1 & 2). Make sure the buckle on the strap is on outer side.
- Insert similarly the other end of the strap by stretching it a bit to the top of the phone (3 & 4).
- Adjust the strap length to your liking and fasten the buckle.

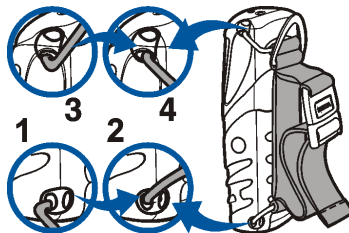

■ Keypad lock (Keyguard)

You can lock the keypad to avoid accidental keypresses.



Press **Menu** and then **+*** within 1.5 seconds.

See also **Automatic keyguard** on page 74.

When the keypad is locked,  appears at the top of the display.

Unlocking the keypad

Press **Unlock** and then **+*** within 1.5 seconds.

When the keyguard is on

- To answer a call press . During a call, the phone can be operated in the normal way. When you end or reject the call, the keypad will be locked automatically.

Activation during a call

- To activate keyguard during a call, press **Options** and select **Lock keypad**





Note: When Keyguard is on, calls may be possible to the emergency number programmed into your phone (e.g. 112 or other official emergency number). Key in the emergency number and press . The number is displayed only after you have keyed in its last digit.



3. Call functions



■ Making a call

1. Key in the phone number, including the area code. If you key in a wrong character, press **Clear** to delete it.
For international calls, press **+*** twice for the international prefix (the + character replaces the international access code) and then key in the country code, area code and the phone number.
2. Press  to call the number.
3. Press  to end the call or to cancel the call attempt.



Making a call using the phone book

- See [Searching for a name in the phone book](#) on page 36. Press  to call the number on the display.

Last number redialling

- In standby mode, press  once to access the list of the 20 numbers you last called or attempted to call. Scroll to the number or name you want, and press  to call the number.

Speed dialling a phone number

- Assign a phone number first to one of the speed dialling keys (-). See [Speed dialling](#) on page 73. Then call the number in either of the two ways:
- Press the speed dialling key you want and then press .



- If *Speed dialling* is set to on, press and hold a speed dialling key until the call is started.

Calling your voice mailbox

- In standby mode, press and hold **001**, or press **001** and .
See also [Voice messages](#) on page 62.



Making a conference call

Conference calling is a network service that allows up to six persons to take part in a conference call.

1. Make a call to the first participant.
2. To make a call to a new participant, press **Options** and select *New call*.
3. Key in, or retrieve from the memory, the phone number of the new participant and press **Call**. The first call is put on hold.
4. When the new call has been answered, join the first participant in the conference call. Press **Options** and select *Conference*.
5. To add a new participant to the call, repeat steps 2 to 4.
6. To have a private conversation with one of the participants:
Press **Options** and select *Private* and select the desired participant. Rejoin the conference call as described in step 4.
7. To end the conference call, press .



■ Answering or rejecting an incoming call

Press  to answer the incoming call and press  to end the call.

Press  to reject the incoming call.

If you press **Silence**, only the ringing tone is muted. Then either answer or reject the call.

If the Stereo Headset HDS-3 or some other compatible Nokia headset is connected to the phone, you can answer and end a call by pressing the headset key.



Tip: If the *Divert if busy* function is activated to divert, rejecting an incoming call will also divert the call. See [Call divert](#) on page 72.

Call waiting

During a call, press  to answer the waiting call. The first call is put on hold.

Press  to end the active call.

To activate the *Call waiting* function, see [Call waiting](#) on page 73.

■ Options during a call

Many of the options that you can use during a call, are network services. Press **Options** during a call for some of the following options:

Mute or Unmute, End call, End all calls, Phone book, Menu and Hold or Unhold, New call, Conference, Private, Answer, Reject Loudspeaker or Handset and Lock keypad.



Send DTMF to send DTMF tone strings, for example, passwords or bank account numbers. Key in the DTMF string or search for it in the phone book and press **OK**. Note that you can key in the wait character w and the pause character p by repeatedly pressing ***★**.

Swap to switch between the active call and the call on hold, *Transfer* to connect a call on hold to an active call, and disconnect yourself from the calls.

Loudspeaker

You can use your phone as a loudspeaker when making or receiving calls. Do not hold the phone to your ear when using the loudspeaker function.

- By arriving call, press **Options** and select *Loudspeaker*. The call is accepted immediately.
- During a call, press **Options** and select *Loudspeaker* or press **Loudsp.** if visible on the phone's display.
- When making a call, wait until the initialising call alerts and then activate the loudspeaker like during a call.

To stop using the loudspeaker, press **Options** and select *Handset* or press **Handset** if visible on the phone's display.

Using the loudspeaker with the radio, see [Using the radio](#) on page 83.

Note: Using the loudspeaker consumes the battery and the phone's operating time will be reduced considerably.



4. Phone book (Names)

You can save names and phone numbers in the phone's memory (internal phone book) and in the SIM card's memory (SIM phone book).

- The internal phone book may save up to 300 names with numbers and textual notes for each name. The number of saved names depends on the length of the names, phone numbers and text items.
- The phone supports SIM cards that can save up to 250 names and phone numbers. Names and numbers saved in the SIM card's memory, are indicated by .

■ Selecting the phone book settings

Press **Names** and select *Settings*. Select

- *Memory in use* to select the phone book you want to use. To recall names and numbers from both phone books, select *Phone and SIM*. The names and numbers will then be saved in the phone's memory.
- *Phone book view* to select how the names (and numbers) in the phone book are displayed.
- *Memory status* to see how many names and phone numbers are currently saved and how many can still be saved in the selected phone book.



■ Saving names and phone numbers (Add name)

Names and numbers will be saved in the used memory, see [Selecting the phone book settings](#) above.

1. Press **Names** and select *Add name*.
2. Key in the name and press **OK**. See [Using traditional text input](#) on page 52.
3. Key in the phone number, and press **OK**. To key in the numbers, see [Making a call](#) on page 30.
4. When the name and number are saved, press **Done**.



Tip: Quick save In standby mode, key in the phone number. Press **Options**, and select *Save*. Key in the name, press **OK** and **Done**.









Saving multiple numbers and text items per name

You can save different types of phone numbers and short text items per name in the phone's internal phone book.





The first number saved is automatically set as the default number and it is indicated with a frame around the number type indicator, for example . When you select a name from the phone book, for example to make a call, the default number is used unless you select another number.

1. Make sure that the memory in use is either *Phone* or *Phone and SIM*. See [Selecting the phone book settings](#) on page 34.
2. To access the list of names and phone numbers, press  in standby mode.



3. Scroll to the name saved in the phone's internal phone book to which you want to add a new number or text item, and press **Details**.
4. Press **Options** and select *Add number* or *Add detail*.
5. Select one of the following number types  *General*,  *Mobile*,  *Home*,  *Office* and  *Fax*, or text types  *E-mail address*,  *Web address*,  *Postal address* and  *Note*.
To change the number or text type, select *Change type* in the options list.
6. Key in the number or text item and press **OK** to save it.
7. Press **Back** and then **Exit** to return to standby mode.

■ Searching for a name in the phone book

1. Press **Names** and select *Search*.
2. You can key in the first characters of the name you are searching for in the pop-up window.
Press  and  to scroll through the names in the list, press  and  to move the cursor in the pop-up window.
3. Scroll to the name you want, and press **Details**. Scroll to view the details of the selected name.



■ Editing a name, number or text item

Search for the name (and number) you want to edit and press **Details**. Scroll to the name, number or text item you want to edit, and press **Options**. Select *Edit name*, *Edit number*, or *Edit detail*, and edit the name, number, or text and press **OK**.

■ Erasing names and numbers

Press **Names** and select *Delete*.

- Select *One by one* and scroll to the name (and number) you want to delete. Press **Delete** and press **OK** to confirm.
- Select *Delete all* and then scroll to the phone book, *Phone* or *SIM card* and press **Delete**. Press **OK** and confirm with the security code.

■ Copying phone books

You can copy names and phone numbers from the phone's memory to your SIM card's memory and vice versa.

1. Press **Names** and select *Copy*.
2. Select the copying direction, *From phone to SIM card* or *From SIM card to phone*.
3. Select *One by one*, *All* or *Default numbers*.
 - If you select *One by one*, scroll to the name you want to copy and press **Copy**.



Default numbers is shown if you copy from the phone to the SIM card. Only the default numbers will be copied.

4. To choose whether you want to keep or delete the original names and numbers, select *Keep original* or *Move original*.
 - If you select *All* or *Default numbers*, press **OK** when *Start copying?* or *Start moving?* is displayed.

■ Sending and receiving a business card

You can send and receive a person's contact information as a business card either via IR or as an Over The Air (OTA) message if supported by the network.

Receiving a business card

To receive a business card via IR, make sure that your phone is ready to receive data through its IR port, see [Infrared](#) on page 101.

When you have received a business card via IR or as an OTA message, press **Show**. Press **Save** to save the business card in the phone's memory. To discard the business card, press **Exit** and then **OK**.

Sending a business card

You can send a business card via IR or as an OTA message to a compatible phone or other handheld device which supports the vCard standard.

1. Search for the name and phone number you want to send from the phone book, press **Details** and **Options** and select *Send bus. card*.



2. To send the business card via IR, make sure that the other phone or the PC is set up to receive data via its IR port and select *Via infrared*.

To send the business card as an OTA message, select *Via text message*.

■ Speed dials

To make a call by using the speed dialling keys, see [Speed dialling](#) on page 73.

Assigning a number to a speed dialling key

Press **Names**, select *Speed dials* and scroll to the speed dialling key number you want.

Press **Assign**, press **Search**, and select first the name and then the number you want to assign. If a number is already assigned to the key, press **Options**, and you can view, change or delete the assigned number.

■ Info and service numbers

You can call the information and service numbers of your service provider if the numbers are included in your SIM card.

Press **Names** and select *Info numbers* or select *Service numbers*. Scroll to an information number or to a service number and press  to call the number.



■ My numbers

The phone numbers assigned to your SIM card are saved in *My numbers* if this is allowed by the SIM card. To view the numbers press **Names** and select *My numbers*. Scroll to the desired name or number, and press **View**.

■ Caller groups

You can arrange the names and phone numbers saved in the phone book into caller groups. For each caller group, you can set the phone to sound a specific ringing tone and show a selected graphic on the display when you receive a call from a phone number in the group, see below. To set the phone to ring only upon calls from phone numbers belonging to a selected caller group, see *Alert for in Tone settings* on page 78.

Press **Names**, and select *Caller groups* and select the desired caller group. Select

- *Group name*, key in a new name for the caller group and press **OK**.
- *Group ringing tone* and select the ringing tone for the group. *Default* is the ringing tone selected for the currently active profile.
- *Group logo* and select *On* to set the phone to display the group logo, *Off* not to display it, or *View* to view the logo.
- *Group members* to add a name to the caller group, press **Options** and select *Add name*. Scroll to the name you want to add to the group and press **Add**.

To remove a name from a caller group, scroll to the name you want to remove, and press **Options** and select *Remove name*.









5. Using the menu

The phone offers you an extensive range of functions that are arranged in menus and submenus.

Most of the menu functions are provided with a brief help text. Help text activation can be set separately, see the page 76. To view the help text, scroll to the menu function you want and wait for 15 seconds.

■ Accessing a menu function

By scrolling

1. To enter the main menu, press **Menu**, scroll with  or  for example to **Settings** and press **Select**.
2. If the menu contains any submenus, for example **Call settings**, scroll with  or  to the one you want and press **Select**.
If the menu you have selected contains submenus, repeat this step.
3. Scroll with  or  to the setting you want and press **Select**. To return to previous menu level, press **Back**.



Tip: You can exit the menu without changing the menu settings by pressing



By shortcut

The menus, submenus and setting options are numbered and you can access them by using their shortcut numbers.

1. Press **Menu** in the standby mode.
2. Within two seconds, key in the first digit of the shortcut number. Repeat this for each digit of the shortcut number.



■ List of menu functions

1. Messages



1. Text messages
 1. Create message
 2. Inbox
 3. Create e-mail
 4. Sent items
 5. Archive
 6. Templates
 7. My folders
 8. Delete messages
2. Multimedia msgs.
 1. Create message
 2. Inbox
 3. Outbox
 4. Sent items
 5. Saved items
 6. Delete messages
3. Chat
4. Voice messages
 1. Listen to voice messages
 2. Voice mailbox number
5. Info messages
 1. Info service
 2. Topics
 3. Language



- 4. Info topics saved on SIM card
 - 5. Read
 - 6. Message settings
 - 1. Text messages
 - 2. Multimedia msg.s.
 - 3. Other settings
 - 7. Service commands
- 2. Call register**
- 1. Missed calls
 - 2. Received calls
 - 3. Dialed numbers
 - 4. Delete recent call lists
 - 1. All
 - 2. Missed
 - 3. Received
 - 4. Dialed
 - 5. Call duration
 - 1. Last call duration
 - 2. Received calls' duration
 - 3. Dialed calls' duration
 - 4. All calls' duration
 - 5. Clear timers
 - 6. Call costs
 - 1. Last call units
 - 2. All calls' units
 - 3. Call cost settings



7. GPRS data counter
 1. Data sent in last session
 2. Data received in last session
 3. All sent data
 4. All received data
 5. Clear counters
8. GPRS connection timer
 1. Duration of last session
 2. Duration of all sessions
 3. Clear timers

3. Profiles

1. General
 1. Activate
 2. Personalise
 3. Timed
2. Silent (same submenus as in General)
3. Meeting (same submenus as in General)
4. Outdoor (same submenus as in General)
5. Pager (same submenus as in General)



4. Settings

1. Time and date settings
 1. Clock
 2. Date
 3. Auto-update of date & time



2. Call settings
 1. Automatic volume control
 2. Call divert
 3. Anykey answer
 4. Automatic redial
 5. Speed dialling
 6. Call waiting
 7. Summary after call
 8. Send my caller identity
 9. Line for outgoing calls¹
3. Phone settings
 1. Language
 2. Automatic keyguard
 3. Cell info display
 4. Welcome note
 5. Network selection
 6. Confirm SIM service actions
 7. Help text activation
 8. Start-up tone
4. Display settings
 1. Wallpaper
 2. Colour schemes
 3. Operator logo
 4. Screen saver timeout
 5. Display brightness
5. Tone settings

1. For availability, contact your network operator or service provider.



1. Incoming call alert
 2. Ringing tone
 3. Ringing volume
 4. Vibrating alert
 5. Light alert
 6. Message alert tone
 7. Keypad tones
 8. Warning tones
 9. Alert for
6. Accessory settings¹
 1. Headset
 2. Handsfree
 3. Loopset
 7. Security settings
 1. PIN code request
 2. Call barring service
 3. Fixed dialling
 4. Closed user group
 5. Security level
 6. Access codes
 8. Restore factory settings

5. Alarm clock



-
1. This menu is shown only if the phone is or has been connected to a headset, handsfree unit or loopset available for the phone.



6. Radio



7. Gallery

1. View folders
2. Add folder
3. Delete folder
4. Rename folder
5. Gallery services



8. Organiser

1. Calendar
2. To-do list



9. Games

1. Select game
2. Game services
3. Memory
4. Settings



10. Applications

1. Select application
2. App. services
3. Memory



11.Extras

1. Calculator
2. Countdown timer



3. Stopwatch
4. Calorie counter
5. Thermometer
6. Sound meter

12.Connectivity

1. Infrared
2. GPRS
 1. GPRS connection
 2. GPRS modem settings



13.Services

1. Home
2. Bookmarks
3. Service inbox
4. Settings
 1. Active service settings
 2. Edit active service settings
 3. Appearance settings
 4. Cookie settings
 5. Authority certificates
 6. Service inbox settings
5. Go to address
6. Clear the cache



14.SIM services¹



-
1. Only shown if supported by your SIM card. The name and contents vary depending on the SIM card



6. Menu functions

■ Messages (Menu 1)

You can read, write, send and save text, multimedia, and e-mail messages. All messages are organised into folders.



WARNING: Do not switch the phone on when wireless phone use is prohibited or when it may cause interference or danger.

Before you can send any text, picture, or e-mail message, you need to save your message centre number, see [Message settings](#) on page 63.



Note: When sending messages, your phone may display the words "*Message sent*". This is an indication that the message has been sent by your phone to the message centre number programmed into your phone. This is not an indication that the message has been received at the intended destination. For more details about messaging services, check with your service provider.

Your phone can send and receive multi-part messages, which consist of several ordinary text messages (network service). Invoicing is based on the number of ordinary messages that are required for a multi-part message.

You can also send and receive text messages that contain pictures. Each picture message is made up of several text messages. Therefore, sending one picture message may cost more than sending one text message.





Note: Picture message function can be used only if it is supported by your network operator or service provider. Only phones that offer picture message features can receive and display picture messages.



Text messages

You can key in text, for example when writing messages, using the traditional or predictive text input.

Using traditional text input

Press a number key,  to , repeatedly until the desired character appears. Not all characters available under a number key are printed on the key. The characters available depend on the language selected in the *Language* menu, see [Language](#) on page 74.

To insert a number while in letter mode, press and hold the desired number key.

- If the next letter you want is located on the same key as the present one, wait until the cursor appears, or press any of the scroll keys and then key in the letter.
- The most common punctuation marks and special characters are available under the number key .

Setting predictive text input on or off

When writing text, press *Options* and select *Dictionary*.

- To set the predictive text input on, select a language in the dictionary options list. Predictive text input is only available for the languages on the list.
- To change back to the traditional text input, select *Dictionary off*.



Tip: To quickly set the predictive text input on or off when writing text, press  twice, or press and hold *Options*.



Using predictive text input

You can key in any letter with a single keypress. The predictive text input is based on a built-in dictionary to which you can also add new words.

1. Start writing a word by using the keys **2** to **9**. Press each key only once for one letter. The word changes after each keystroke.

To insert a number while in letter mode, press and hold the desired number key.

2. When you have finished writing the word and it is correct, confirm it by adding a space with **0**, or by pressing any of the scroll keys. Pressing a scroll key also moves the cursor.

If the word is not correct,

press ***★** repeatedly or press **Options** and select **Matches**. When the word you want appears, confirm it.

If the **?** character is displayed after the word, the word you intended to write is not in the dictionary. To add the word to the dictionary, press **Spell**, key in the word (traditional text input is used) and press **Save**. When the dictionary becomes full, the new word replaces the oldest one that was added.

3. Start writing the next word.

Writing compound words

Key in the first part of the word and confirm it by pressing **)**. Write the last part of the word and confirm the word.



Writing and sending messages

The number of available characters and the current part number of a multi-part message are shown on the top right of the display.

1. Press **Menu**, and select *Messages, Text messages* and *Create message*.



Tip: To quickly open the message editor, press **(** in standby mode.

2. Key in a message. To insert text templates or a picture into the message, see [Templates](#) on page 57.
3. To send the message, press **Options** and select *Send*.
4. Enter the recipient's phone number or search for the phone number in the phone book.
Press **OK** to send the message.

Options for sending a message

After you have written a message, press **Options** and select *Sending options*.

- To send a message to several recipients, select *Send to many*. When you have sent the message to everyone you want to send it to, press **Done**.
- To send a message using a message profile, select *Sending profile* and then the desired message profile.

To define a message profile, see [Message settings](#) on page 63.

Writing and sending e-mail

Before you can send e-mail via SMS, you need to save the settings for sending e-mail, see [Message settings](#) on page 63. For availability and subscription to the e-mail service, contact your network operator or service provider. To save an e-mail



address in the phone book, see [Saving multiple numbers and text items per name](#) on page 35.

1. Press **Menu**, and select *Messages, Text messages* and *Create e-mail*.
2. Key in the recipient's e-mail address or search for it in the phone book and press **OK**.
3. If you wish, you can key in the subject for the e-mail and press **OK**.
4. Key in the e-mail message. The total number of characters that you can key in is shown on the top right of the display. The e-mail address and subject are included in the total number of characters.

See also [Inserting a text template into a message or into an e-mail](#) on page 57. Pictures cannot be inserted.

5. To send the e-mail, press **Options** and select *Send e-mail*. If you have not saved the settings for sending e-mails, the phone asks for the number of the e-mail server.

Press **OK** to send the e-mail.

Reading and replying to a message or an e-mail



When you have received a message or an e-mail, the indicator  and the number of new messages followed by *messages received* is shown.

The blinking  indicates that the message memory is full. Before you can receive new messages, delete some of your old messages.

1. Press **Show** to view the new message, or press **Exit** to view it later.

Reading the message later:



- Press **Menu**, and select *Messages, Text messages* and *Inbox*.
- An unread text message is indicated by  in front of it and a picture message that has not been viewed is indicated by .
 - While reading or viewing the message, press **Options**.
You can for example delete, forward or edit the message as a text message or an e-mail, and move or rename the message you are reading.
Select *Copy to calendar* to copy text at the beginning of the message to your phone's calendar as a reminder note for the current day.
Select *Message details* to view the sender's name and phone number, the message centre used, and the date and time of receipt.
Select *Use detail* to extract numbers, e-mail addresses and website addresses from the current message.
When reading a picture message, select *Save picture* to save the picture in the *Templates* folder.
 - Select *Reply* to reply to a message. Select *Original text* to include the original message in the reply, or select a standard answer to be included, or select *Empty screen*.
When replying to an e-mail, confirm or edit the e-mail address and subject first. Then write your reply message.
 - Press **Options**, select *Send*, and press **OK** to send the message to the displayed number.





Inbox and outbox folders

The phone saves incoming text messages in the *Inbox* folder and sent messages in the *Sent items* folder of the *Text messages* submenu.

Text messages that you wish to send later can be saved in the *Archive*, *My folders* or *Templates* folder.

Templates

Your phone includes text templates, indicated by , and picture templates, indicated by .

To access the template list, press **Menu**, and select *Messages*, *Text messages* and *Templates*.

Inserting a text template into a message or into an e-mail

- When you are writing a message or an e-mail, press **Options**. Select *Use template* and select the template that you want to insert.

Inserting a picture into a text message

- When you are writing a message, press **Options**. Select *Insert picture* and select a picture to view it. Press **Insert** to insert the picture into your message. The  indicator means that a picture has been attached. The number of characters that you can enter in a message, depends on the size of the picture. To view the text and the picture together before sending the message, press **Options** and select *Preview*.



Archive folder and my folders

To organise your messages, you can move some of them to the *Archive* folder, or add new folders for your messages.

While reading a message, press **Options**. Select *Move*, scroll to the folder that you want to move the message to and press **OK**.

To add or delete a folder, press **Menu**, and select *Messages, Text messages and My folders*.

- Press **Options** and select *Add folder*.
- Scroll to the folder that you want to delete, press **Options** and select *Delete folder*.

Multimedia messages



Note: This function can be used only if it is supported by your network operator or service provider. Only phones that offer multimedia message features can receive and display multimedia messages.

A multimedia message can contain text, picture and sound. The phone supports multimedia messages that are up to 45 kB in size. If the maximum size is exceeded, the phone may not be able to receive the message. Depending on the network, you may receive a text message that includes an Internet address where you can view the multimedia message.

If the message contains a picture, the phone scales it down to fit the display area.

If the indicator  blinks, the multimedia messages memory is full. To view the waiting message, press **Show**. To save the message, press **Options**, select *Save*



message and delete old messages by first selecting the folder and then an old message to be deleted.



Note: If *Allow multimedia reception* is set *Yes*, your operator or service provider may charge you for every message you receive.

Multimedia messaging supports the following formats:

- Picture: JPEG, GIF, PNG, and BMP.
- Sound: Scalable Polyphonic MIDI (SP-MIDI) and monophonic ringing tones (RGN).

If a received message contains any unsupported elements, they may be replaced with the file name and the text *Object format not supported*.

Writing and sending a multimedia message

To set the settings for multimedia messaging, see [Settings for multimedia messages](#) on page 65. For availability and a subscription to the multimedia messaging service, contact your network operator or service provider.

1. Press **Menu**, and select *Messages, Multimedia msgs.* and *Create message*.
2. Key in a message.

You can insert one picture in a multimedia message. To insert a picture, press **Options**, and select *Insert image*. The list of available folders in the *Gallery* is shown. To open a specific folder, select it and then select the desired picture. The  indicator means that a picture has been attached.

To insert a name from the phone book, press **Options**, select *More options* and *Insert name*. Scroll to the desired name, press **Options** and select *Insert name*.





- To insert a number, press **Options**, select *More options* and *Insert number*. Key in the number or search it in the phone book, and press **OK**.
3. To view the message before sending it, press **Options** and select *Preview*.
 4. To send the message, press **Options** and select *Send to number* (or *Send to e-mail*).
 5. Enter the recipient's phone number (or e-mail address) or search for it in the phone book. Press **OK** and the message is moved to the *Outbox* folder for sending.

It takes more time to send a multimedia message than to send a text message. While the multimedia message is being sent, the animated indicator  is displayed and you can use other functions on the phone. If there is an interruption while the message is being sent, the phone tries to resend it a few times. If this fails, the message will remain in the *Outbox* folder and you can try to resend it later.

The messages that you have sent will be saved in the *Sent items* folder if the setting *Save sent messages* is set to *Yes*. See [Settings for multimedia messages](#) on page 65.

Reading and replying to a multimedia message

When your phone is receiving a multimedia message, the animated indicator  is displayed. When the message has been received, the indicator  and the text *Multimedia message received* are shown.

1. Press **Show** to view the message, or press **Exit** to view it later.



Reading the message later: Press **Menu**, and select *Messages, Multimedia msgs.* and *Inbox*.

2. Scroll to view the message. Press **Options** if you wish to:
 - delete a saved message, reply to the message, forward the message or edit a message.
 - Or select *Message details* to view the subject, size and class of the message, *Play* to listen to the ringing tone that is contained in the message, *Save sound clip* to save the ringing tone in the *Gallery*, *Zoom in* to increase the size of the received picture, *Save image* to save the picture in the *Gallery*.

Inbox, Outbox, Saved and Sent items folders

The phone saves the multimedia messages that have been received in the *Inbox* folder of the *Multimedia msgs.* submenu.

Messages that have not yet been sent are moved to the *Outbox* folder.

Messages that you wish to send later, can be saved in the *Saved items* and messages that have been sent are saved in the *Sent items* folder.

Erasing messages

1. To delete text messages or multimedia messages, press **Menu**, and select *Messages, Text messages* or *Multimedia msgs.* and *Delete messages*.
2. To delete all messages in a folder, scroll to the folder and press **Select**. Confirm the deletion by pressing **OK** after the query.



To delete all read messages from all folders, scroll to *All messages* and press **Select**. Confirm the deletion by pressing **OK** after the query.

Chat

You can have a conversation with another person using this faster text messaging application. You cannot save received or sent messages, but you can view them while chatting. Each chat message is priced as a text message.

1. Press **Menu**, select *Messages* and *Chat*. Key in or search the phone book for the phone number of the person with whom to start a chat session and press **OK**.

Another way to start a chat: When you have received a message, press **Show** to read it. To start a chat, press **Options** and select *Chat*.

2. Key in your nickname for the chat and press **OK**.
3. Write your chat message.
4. To send the message, press **Options** and select *Send*.
5. The reply message from the other person is shown above your original message.

To reply to the message, press **OK** and repeat steps 3 and 4.

6. To end the chat session, press **OK**, press **Options** and select *Quit*.

Voice messages

Voice mailbox is a network service and you may need to subscribe to it. For more information and for the voice mailbox number, contact your service provider.



Press **Menu**, and select *Messages* and *Voice messages*. Select

- *Listen to voice messages* to call your voice mailbox at the phone number that you have saved in the *Voice mailbox number* menu.

Each phone line may have its own voice mailbox number, see [Line for outgoing calls](#) on page 74.

- *Voice mailbox number* to key in, search for or edit your voice mailbox number and press **OK** to save it.

If supported by the network, the indicator  will show new voice messages. Press **Listen** to call your voice mailbox number.



Tip: Pressing and holding  calls your voice mailbox.

Info messages

With the info message network service you can receive messages on various topics from your service provider, for example weather or traffic conditions. For available topics and the relevant topic numbers, contact your service provider.

If the *GPRS connection* is set to *Always online*, the info messages may not be received. In that case, set the *GPRS connection* to *When needed*, see [GPRS connection](#) on page 102.

Message settings

Settings for text and e-mail messages

1. Press **Menu**, and select *Messages*, *Message settings*, *Text messages* and *Sending profile*.



2. If more than one message profile set is supported by your SIM card, select the set you want to change.
- Select *Message centre number* to save the phone number of the message centre that is required for sending text messages. You will receive this number from your service provider.
 - Select *Messages sent as* to select the message type *Text*, *E-mail*, *Paging* or *Fax*.
 - Select *Message validity* to select the length of time for which the network should attempt to deliver your message.
 - For message type *Text*, select *Default recipient number* to save a default number for sending messages for this profile.
For message type *E-mail*, select *E-mail server* to save the e-mail server number.
 - Select *Delivery reports* to ask the network to send delivery reports for your messages (network service).
 - Select *Use GPRS* to set GPRS as the preferred SMS bearer.
 - Select *Reply via same centre* to allow the recipient of your message to send you a reply via your message centre (network service).
 - Select *Rename sending profile* to change the name of the selected message profile.



Overwrite settings

When the text message memory is full, the phone cannot receive or send any new messages. However, you can set the phone to automatically replace old text messages with the new ones.

Press **Menu**, and select *Messages*, *Message settings*, *Text messages* and *Overwriting in inbox* or *Overwriting in sent items*. Select *Allowed* to set the phone to replace the old text messages with new ones in the *Inbox* or the *Sent items* folder, respectively.

Settings for multimedia messages

Press **Menu**, and select *Messages*, *Message settings* and *Multimedia msgs.*. Select

- *Save sent messages*. Select *Yes* to set the phone to save sent multimedia messages in the *Sent items* folder.
- *Allow multimedia reception*. Choose *No*, *Yes* or *In home network* to use multimedia service. If you choose *In home network*, you cannot receive multimedia messages when outside your home network.
- *Incoming multi-media messages*. Select *Retrieve* to set the phone to automatically fetch newly received multimedia messages, or select *Reject* if you do not wish to receive them.
- *Connection settings*. Define WAP connection settings for retrieving multimedia messages. Activate the set where you want to save the connection settings and then edit the settings.
 - *Settings' name*. Key in the new name for the connection set and press **OK**.



- *Homepage*. Key in the homepage address of the WAP service that you want to use, press **0** for a dot, and press **OK**.
- *Session mode*. Select *Permanent* or *Temporary*.
- *Data bearer*. Select *GPRS*.
- *GPRS access point*. Key in the access point name and press **OK**. An access point name is needed to establish a connection to a GPRS network. You obtain the access point name from your network operator or service provider.
- *IP address*. Key in the address, press **+** for a dot, and press **OK**. You obtain the IP address from your network operator or service provider.
- *Authentication type*. Select *Secure* or *Normal*.
- *User name*. Key in the user name and press **OK**.
- *Password*. Key in the password and press **OK**.
- *Allow adverts*. You can receive or reject adverts.

To receive the multimedia connection settings as a text message

You may receive the service settings as a text message from the network operator or service provider that offers the WAP service that you want to use. For more information, contact your network operator or service provider, or visit Club Nokia's website (www.club.nokia.com).

Font size setting

To select the font size for reading and writing messages, press **Menu**, and select *Messages*, *Message settings*, *Other settings* and *Font size*.



Service commands

Press **Menu**, and select *Messages* and *Service commands*. Key in and send service requests (also known as USSD commands), such as activation commands for network services, to your service provider.

■ Call register (Menu 2)



The phone registers the phone numbers of dialled calls, and the approximate length and cost of your calls.

The phone registers missed and received calls only if the network supports these functions, the phone is switched on and within the network's service area.

When you press **Options** in the *Missed calls*, *Received calls* and *Dialled numbers* menu, you can, for example, view the date and the time of the call, edit or delete the phone number from the list, save the number in the phone book, or send a message to the number.

Recent calls lists

Press **Menu**, and select *Call register* and then select

- *Missed calls* to view the list of the last ten phone numbers from which somebody has tried to call you (network service).



Tip: When a note about missed calls is being displayed, press **List** to access the list of phone numbers. Scroll to the number you would like to call back and press 



- *Received calls* to view the list of the last ten phone numbers from which you have most recently accepted calls (network service).
- *Dialled numbers* to view the list of the 20 phone numbers that you have most recently called or attempted to call. See also [Last number redialling](#) on page 30.
- *Delete recent call lists* to delete the recent calls lists. Select whether you want to delete all the phone numbers in the recent call lists, or only those numbers in the missed calls, received calls or dialled numbers lists. You cannot undo the operation.

Call counters and call timers



Note: The actual invoice for calls and services from your service provider may vary, depending upon network features, rounding-off for billing, taxes and so forth.

Press **Menu**, and select *Call register* and then select

- *Call duration*, scroll to view the approximate duration of your incoming and outgoing calls in hours, minutes and seconds. To clear the timers, the security code is needed.
Each phone line has its own call timers and the timers of the selected line are displayed. See [Line for outgoing calls](#) on page 74.
- *Call costs* (network service). Select *Last call units* or *All calls' units* to check the cost of your last call or all calls in terms of units specified within the *Show costs in* function.



Select *Call cost limit* to limit the cost of your calls to a certain amount of charging units or units of currency. The PIN2 code is needed for the call cost settings.



Note: When no more charging units or currency units are left, calls may only be possible to the emergency number programmed into your phone (e.g. 112 or other official emergency number).

- *GPRS data counter*, scroll to check the amounts of sent and received data in last session, data sent and received in total, and to clear the counters. The counters unit is a byte. To clear the counters, the security code is needed.
- *GPRS connection timer*, scroll to check the duration of the last GPRS connection or the total GPRS connection. You can also clear the timers. To clear the timers, the security code is needed.

■ Profiles (Menu 3)



Your phone has various setting groups, profiles, for which you can customise the phone tones for different events and environments.

At first, personalise the profiles to your liking and then you only need to activate a profile to use it. Available profiles are *General*, *Silent*, *Meeting*, *Outdoor*, and *Pager*.

Press **Menu**, and select *Profiles*. Scroll to a profile and press **Select**.

- To activate the selected profile, select *Activate*.
- To set the profile to be active for a certain amount of time up to 24 hours, select *Timed* and set the end time. When the time set for the profile expires, the previous profile that was not timed, activates.



- To personalise the profile, select *Personalise*. Select the setting you want to change and make the changes.

The settings can also be changed in the *Tone settings* menu, see page 78.

In addition you can rename a profile, *Profile name*. The *General* profile can not be renamed.



Tip: To change the profile quickly in standby mode, press the power key , scroll to the profile you want to activate and press *Select*.

■ Settings (Menu 4)



Time and date settings

Clock

Press *Menu*, and select *Settings, Time and date settings* and *Clock*.

Select *Show clock* to show the time on the top right of the display in standby mode. Select *Set the time* to adjust the clock to the correct time, and *Time format* to select 12-hour or 24-hour time format.

The clock serves the functions *Messages, Call register, Alarm clock*, timed *Profiles, Calendar* and screen saver, for example.

If the battery is removed from the phone for a long time, you may need to set the time again.

Date

Press *Menu*, and select *Settings, Time and date settings* and *Date*.



Select *Show date* and the date is shown on the display when the phone is in standby mode. Select *Set the date* to adjust the date. You can also select the date format.

Auto update of date and time

Press **Menu**, and select *Settings, Time and date settings* and *Auto-update of date & time* (network service). To set the phone to automatically update the time and date according to the current time zone, select *On*. To set the phone to ask for a confirmation before the update, select *Confirm first*.

The automatic update of the date and time does not change the time that you have set for the alarm clock, calendar or the alarm notes. They are in local time. Updating may cause some alarms that you have set to expire.

Call settings

Note: The following call settings can all be found by pressing first **Menu**, and selecting *Settings, Call settings* and then selecting the needed setting.

Automatic volume control

Automatic volume control controls the earpiece's volume level according to the environment noise level. If the environmental noise and/or level of received speech changes, Automatic volume control changes also the earpiece's volume level accordingly.

Note: Auto volume on or off setting during an active call affects only the current call. The usage of Automatic volume control is possible only in handportable mode.



Activating Automatic volume control via a menu

1. Select *Automatic volume control*.
2. Choose either *Off* or *On*. The default is *Off*.

Activating Automatic volume control during a call

1. Press **Options** during an active call.
2. Select *Auto volume on* if you want to activate the Automatic volume control or select *Auto volume off* if you want to turn it off.

If you increase the volume level during an active call by pressing the volume key , the phone's volume level increases regardless of Automatic volume control being on or off.

When you end the call, the volume level returns to the level previous to Automatic volume control adjustment.

Call divert

Select *Call divert* (network service) and you can divert your incoming calls to another number, for example, to your voice mailbox number. For details, contact your service provider. Divert options not supported by your SIM card or your network operator may not be shown.





Select the divert option you want, for example, select *Divert if busy* to divert the voice calls when your number is busy or when you reject an incoming call.

To set the divert setting to on, select *Activate*, to set the divert setting to off, select *Cancel*, or *Check status* to check whether the divert is activated or not. To change the timeout when the call is diverted, first select *Set delay* if this is



available for the divert option, and then select *Activate* to set the divert setting to on. Several divert options may be active at the same time.



Anykey answer

Select *Anykey answer*. Select *On* and you can answer an incoming call by briefly pressing any key, except , selection keys  and , and .

Automatic redial

Select *Automatic redial*. Select *On* and your phone will make up to ten attempts to connect the call after an unsuccessful call attempt.

Speed dialling

Select *SettingsSpeed dialling*. Select *On* and the names and phone numbers assigned to the speed dialling keys, from  to , can be dialled by pressing and holding the corresponding number key.

Call waiting

Select *Call waiting - Activate* and the network will notify you of an incoming call while you have a call in progress (network service). See [Call waiting](#) on page 32.

Summary after call

Select *Summary after call*. Select *On* and the phone will briefly display the duration and cost (network service) of the last call.

Send my caller identity

Select *Send my caller identity*. Select *Yes* and your phone number will be displayed to the person you are calling (network service). Select *Set by network* and the setting agreed upon with your service provider is used.



Line for outgoing calls

Line for outgoing calls is a network service to select the phone line 1 or 2, that is subscriber number, for making calls.

Select *Line for outgoing calls*. If you select *Line 2* and have not subscribed to this network service, you will not be able to make calls. However, calls on both lines can be answered regardless of the selected line.

If supported by your SIM card, you can prevent the line selection by selecting the option *Lock*.

For more information on availability, contact your network operator or service provider.



Tip: In standby mode you can switch from one line to the other by pressing and holding #⁰.

Phone settings

Note: The following phone settings can all be found by pressing first *Menu*, and selecting *Settings*, *Phone settings*, and then selecting the needed setting.

Language

Select *Language*. Select the language for the display texts. If *Automatic* is selected, the phone selects the language according to the information on the SIM card.

Automatic keypad

When the keypad is locked,  appears at the top of the display.





Note: When Keyguard is on, calls may be possible to the emergency number programmed into your phone (e.g. 112 or other official emergency number). However, one key emergency dialling ('the 9 key') does not operate. Key in the emergency number and press . The number is displayed only after you have keyed in its last digit.

You can set time delay for your keypad and when that time is up the keypad is locked automatically preventing accidental keypresses.

1. Select *On* if you want to set the automatic keypad lock on.
2. Give the time entry in minutes and seconds after *Set delay*: appears on the display.
The default is 01:00. The maximum time entry for the delay is 60 minutes and the minimum entry 10 seconds.

The automatic keyguard activates if the phone is in standby mode and a user selectable time delay expires.

Cell info display

Select *Cell info display*. Select *On* to set the phone to indicate when it is used in a cellular network based on Micro Cellular Network (MCN) technology.

If the *GPRS connection* is set to *Always online*, the info messages may not be received. In that case, set the *GPRS connection* to *When needed*, see [GPRS connection](#) on page 102.

Welcome note

Select *Welcome note*. Key in the note you would like to be shown briefly when the phone is switched on. To save the note, press *Options*, and select *Save*.



Network selection

Select *Network selection*. Select *Automatic* and the phone automatically selects one of the cellular networks available in your area.

If you select *Manual*, you can select a network that has a roaming agreement with your home network operator. If *No access* is displayed, you must select another network. The phone stays in manual mode until the automatic mode is selected or another SIM card is inserted.

Confirm SIM service actions

See *SIM services (Menu 14)* on page 115.

Help text activation

Select *Help text activation* to set the phone to show or hide the help texts. See also *Using the menu* on page 41.

Start-up tone

Select *Start-up tone* to set the phone to play or not to play a start-up tone when the phone is switched on.

Display settings

Note: The following display settings can all be found by pressing first *Menu*, and selecting *Settings*, *Display settings*, and then selecting the needed setting.

Wallpaper

You can set your phone to display a background picture, wallpaper, when the phone is in standby mode. Some pictures are presaved in the *Gallery* menu. You



can also receive pictures via multimedia message, download them from WAP pages or transfer them with PC Suite from your PC and then save them in *Gallery*. Your phone supports JPEG, GIF, BMP and PNG formats.

Selecting a wallpaper picture

1. Select *Wallpaper*.
2. Select *Change image* and the folder list in the *Gallery* menu is shown.
3. Select the folder and scroll to the desired picture.
4. To set the picture as wallpaper, press *Options* and select *Set as wallpaper*.

Note that if you delete the selected wallpaper picture from the gallery, it will still be used as wallpaper until you replace it with another picture.

Note that the wallpaper is not displayed when the phone activates the screen saver.

Activating or deactivating the wallpaper

Select *Wallpaper*. To activate/deactivate the wallpaper, select *On/Off*, respectively.

Colour schemes

Select *Colour schemes*. Select the desired colour scheme e.g. for indicators and signal bars.

Operator logo

To set your phone to display or hide the operator logo, select *Operator logo*.



Note that the operator logo is not displayed when the phone activates the screen saver.

For more information on availability of an operator logo via SMS, MMS or WAP, contact your network operator or service provider.

Screen saver

Digital clock screen saver is used for power saving in standby mode. It will be activated when no function of the phone is used for a certain time. Press any key to deactivate the screen saver. Screen saver is also deactivated when the phone is out of the network coverage area.

Select *Screen saver timeout* and select the timeout when the digital clock display will be activated. The length of the timeout can vary from 5 seconds to 60 minutes.

Note that the screen saver overrides all the graphics and texts on the display in standby mode.

Display brightness

You can change the display brightness. Select *Display brightness*, scroll with (and) to decrease and increase brightness and press **OK** to accept it.

Tone settings

Press **Menu**, and select *Settings* and then *Tone settings*. You can find the same settings in the *Profiles* menu, see [Profiles \(Menu 3\)](#) on page 69. Note that the settings you make, change the settings in the active profile.



- Select *Incoming call alert* to select how the phone notifies you of an incoming voice call. The options are *Ringing*, *Ascending*, *Ring once*, *Beep once* and *Off*.
- Select *Ringing tone* for incoming voice calls. To select ringing tones that have been saved in the *Gallery*, select *Open gallery* from the ringing tone list.
- Select *Ringing volume* and *Vibrating alert* for incoming voice calls and messages. The vibrating alert does not work when the phone is connected to a charger, a desktop stand, or a car kit.



Tip: If you receive a ringing tone via OTA or by downloading, you can save the ringing tone in the *Gallery*.

- Select *Light alert* to set the phone to flash the integrated flashlight during an arriving call.

Note: If you have switched the flashlight on before the incoming call, the flashlight will not flash.

- Select *Message alert tone* to set the alert tone for the incoming messages, *Keypad tones*, or *Warning tones* to set the phone to sound tones for example, when the battery is running out of power.
- Select *Alert for* to set the phone to ring only upon calls from phone numbers that belong to a selected caller group. Scroll to the caller group you want or *All calls* and press *Mark*.

Accessory settings

Accessory settings menu is shown only if the phone is or has been connected to one of the compatible headsets or loopsets.



Press **Menu**, and select **Settings** and **Accessory settings**. You can select **Headset** or **Loopset** if the corresponding accessory is or has been connected to the phone.

- Select **Default profile** to select the profile you want to be automatically activated when you connect the selected accessory. You can select another profile while the accessory is connected.
- Select **Automatic answer** to set the phone to answer an incoming call automatically after five seconds. If the **Incoming call alert** is set to **Beep once** or **Off**, automatic answer will not be in use.
- Select **Lights** to set the lights permanently **On**. Select **Automatic** to set the lights on for 15 seconds after a keypress. The **Lights** option is available only when **Handsfree** is selected.

Security settings



Note: When security features that restrict calls are in use (call barring, closed user group and fixed dialling), calls may be possible to certain emergency numbers in some networks (e.g. 112 or other official emergency numbers).

Press **Menu**, and select **Settings** and **Security settings**. Select

- **PIN code request** to set the phone to ask for your PIN code every time the phone is switched on. Some SIM cards do not allow the PIN code request to be turned off.
- **Call barring service** (network service) to restrict incoming calls to and outgoing calls from your phone. A barring password is required.



- *Fixed dialling* to restrict your outgoing calls to selected phone numbers if this function is supported by your SIM card. The PIN2 code is required.
- *Closed user group* is a network service that specifies the group of people whom you can call and who can call you. For more information contact your network operator or service provider.
- *Security level*. Select *Phone* and the phone will ask for the security code whenever a new SIM card is inserted into the phone.
Select *Memory* and the phone will ask for the security code when SIM card's memory is selected and you want to change the memory in use, (see [Selecting the phone book settings](#) on page 34) or copy from one memory to another ([Copying phone books](#) on page 37).
- *Access codes* to change the security code, PIN code, PIN2 code or barring password. Codes can only include numbers from 0 to 9.

Restore factory settings

To reset some of the menu settings to their original values, press **Menu**, and select *Settings* and *Restore factory settings*. Key in the security code and press **OK**. Note that the data you have keyed in or downloaded, for example, the names and phone numbers saved in the phone book are not deleted.

■ Alarm clock (Menu 5)

The alarm clock uses the time format set for the clock. The alarm clock works even when the phone is switched off.



Press **Menu**, and select **Alarm clock**. Key in the alarm time and press **OK**. To change the time when the alarm time is set, select **On**.

When the alarm time expires

The phone will sound an alert tone, and flash **Alarm!** and the current time on the display.

Press **Stop** to stop the alarm. If you let the phone continue to alarm for a minute or press **Snooze**, the alarm stops for about ten minutes and then resumes.

If the alarm time is reached while the phone is switched off, the phone switches itself on and starts sounding the alarm tone. If you press **Stop**, the phone asks whether you want to activate the phone for calls. Press **No** to switch off the phone or **Yes** to make and receive calls.



Note: Do not press **Yes** when wireless phone use is prohibited or when it may cause interference or danger.

■ Radio (Menu 6)

WARNING: Do not switch the phone on when wireless phone use is prohibited or when it may cause interference or danger.



To listen to the radio on your phone connect the Stereo Headset HDS-3 or some other compatible Nokia headset connector on the bottom of the phone. The lead of the headset functions as the antenna of the radio, so it should also be used when listening to the radio through the loudspeaker.

Note that the quality of the radio broadcast depends on the radio station's coverage in that particular area.



1. To turn on the radio, press **Menu** and select **Radio**. On the display are
 - Channel location number and the name of the radio channel.
 - Frequency of the radio channel.
2. If you have already saved radio channels, you can scroll to the channel you would like to listen to, or select a radio channel location 1 to 9 by pressing the corresponding number key.



When using the Stereo Headset HDS-3 or some other compatible Nokia headset, press the headset key to scroll to the desired saved radio channel.

3. When the radio is on, press **Options** and select **Switch off** to turn off the radio.



Tip: To quickly turn off the radio, press and hold .

Tuning a radio channel

When the radio is on, press and hold  or  to start the channel search. Searching stops when a channel is found. To save the channel, press **Options**, and select **Save channel**. Key in the name of the channel and press **OK**. Select the location where you want to save the channel.

Using the radio

Note: Using the radio consumes the battery and the phone's operating time will be reduced considerably.

When the radio is on, press **Options** and select

- **Switch off** to turn off the radio.



- *Save channel* to save the radio channel you have found. Up to 20 radio channels can be saved.
- *Automatic tuning*. Briefly press either of the scroll keys to start the channel search. The search stops when a channel has been found, press **OK**. To save the channel, see *Save channel* above.
- *Manual tuning*. Briefly press either of the scroll keys to move the channel search 0.1 MHz upwards or downwards or press and hold down the keys to quickly search upwards or downwards for a channel. To save the channel, press **OK** and see *Save channel* above.



Tip: To quickly select *Manual tuning*, press #* when in the *Radio* menu.

- *Set frequency*. If you know the frequency of the radio channel you would like to listen to (between 87.5 MHz and 108.0 MHz), key it in and press **OK**. To save the channel, see *Save channel* above.



Tip: To quickly select *Set frequency*, press +* when in the *Radio* menu.

- *Delete channel*. Scroll to the saved channel, press **Delete**, and **OK**.
- *Rename*. Key in a new name for the saved channel and press **OK**.
- *Loudspeaker* (or *Headset*) to listen to the radio using the loudspeaker (or headset). Keep the headset connected to the phone. The lead of the headset functions as the antenna of the radio.

Note: Using the loudspeaker consumes the battery and the phone's operating time will be reduced considerably.



- *Mono output* (or *Stereo output*) to listen to the radio in mono (or in stereo).

You can normally make a call or answer an incoming call while listening to the radio. The volume of the radio is muted. When you end the call, the radio will automatically be turned on.

When an application using a GPRS or HSCSD connection is sending or receiving data, it may interfere with the radio.

■ Gallery (Menu 7)

WARNING: Do not switch the phone on when wireless phone use is prohibited or when it may cause interference or danger.



You can save images and ringing tones, for example, that have been received in multimedia messages in the folders of the gallery, see [Reading and replying to a multimedia message](#) on page 60.

1. Press **Menu** and select *Gallery*. The list of options is shown.
2. Select *View folders* to open the list of folders.

Other available options are:

- *Add folder*. Key in a name for the folder and press **OK**.
- *Delete folder*. You cannot delete the original folders on the phone.
- *Rename folder*. You cannot rename the original folders on the phone.
- *Gallery services* to download more images and tones. Select *Image services* or *Tone services*, respectively. The list of available WAP bookmarks is shown.



Select *More bookmarks* to access the list of WAP bookmarks in the *Services* menu, see [Bookmarks](#) on page 111.

Select the appropriate bookmark to connect to the desired WAP page. If the connection fails, you may not be able to access the WAP page from the WAP service whose connection settings are currently active. In this case, enter the *Services* menu and activate another set of service settings, see [Making a connection to a WAP service](#) on page 107. Try again to connect to the WAP page.

For the availability of different WAP services, pricing and tariffs, contact your network operator and/or the WAP service provider.

3. Select the desired folder and the list of files in the folder is shown. *Graphics* and *Tones* are the original folders in the phone.
4. Scroll to the desired file. Press *Options* to select desired options for the file.

■ **Organiser (Menu 8)**

WARNING: Do not switch the phone on when wireless phone use is prohibited or when it may cause interference or danger.



Calendar

The calendar helps you to keep track of reminders, calls that you need to make, meetings, and birthdays.

Press *Menu*, and select *Organiser* and *Calendar*.



Scroll to the day you want. The current day is indicated with a frame around the day. If there are any notes set for the day, the day is bolded. To view the day notes, press **Options** and select *Day notes*.





To view a single note, scroll to the note you want to view, press **Options** and select *View*. You can scroll through the note.

The other options for the calendar views may include:

- Options for making a note, for sending a note via IR, or as a note directly to another phone's calendar or as a text message.
- Options for deleting, editing, moving and repeating a note and for copying a note to another day.
- *Settings* to set the date, time, date or time format, or the first day of the week. In the *Auto-delete* option you can set the phone to delete old notes automatically after a specified time. However, the repeat notes, for example, birthday notes, will not be deleted.

Making a calendar note

Press **Menu**, and select *Organiser* and *Calendar*. Scroll to the date you want, press **Options** and select *Make a note*. Select one of the following note types:

-  Meeting
-  *Call*
-  Birthday
-  *Memo*





-  **Reminder**

To set the alarm for the reminder, select *Alarm on* and then set the alarm time.

To set the alarm for the other calendar notes above (except for *Reminder*), after keying in the information for the note type and pressing **OK**, select *With tone* or *Silent* and then set the alarm time.

When you have set the alarm, the indicator  is displayed when you view the notes.

When the phone alarms for a note

The phone beeps, and displays the note. With a call note  on the display, you can call the displayed number by pressing . To stop the alarm and view the note, press **View**. To stop the alarm without viewing the note, press **Exit**.

To-do list

You can save a note for a task that you have to do, select a priority level for the note and mark it as done when you have completed it. You can sort the notes by priority or by date.

Press **Menu**, and select *Organiser* and *To-do list* and the list of notes is shown.

Press **Options**, or scroll to the desired note and press **Options**.

- To add a new note, select *Add*. Key in the subject for the note. When you have keyed in the maximum number of characters for a note, no more characters are accepted. Press **Options** and select *Save*. Select the priority for the note, *High*, *Medium*, or *Low*.

Dictionary, refer to [Setting predictive text input on or off](#) on page 52.



- You can set, delete and edit the deadline and an alarm for a note, and you can also view, delete or edit the selected note and delete all the notes that you have marked as done. You can edit the priority of the selected note, send a note to another phone, save a note as a calendar note, or access the calendar.

■ Games (Menu 9)





WARNING: Do not switch the phone on when wireless phone use is prohibited or when it may cause interference or danger.

Launching a game

1. Press **Menu**, and select *Games* and *Select game*.
2. Scroll to a game or a game set (name depends on the game).
3. Press **Options** and select *Open*, or press . If the selection is a single game it will be launched.

Otherwise, a list of games in the selected game set is displayed. To launch a single game, scroll to the desired game and press **Options** and select *Open*, or press .



Tip: If a game uses the whole display area, no selection key names are displayed. Press the selection key  or  to show the options list. Then select one of the options or press **Back** to continue with the game.



Game services

Press **Menu**, and select *Games* and *Game services*. The list of available WAP bookmarks is shown. Select *More bookmarks* to access the list of WAP bookmarks in the *Services* menu, see [Bookmarks](#) on page 111.

Select the appropriate bookmark to connect to the desired WAP page. If the connection fails, you may not be able to access the WAP page from the WAP service whose connection settings are currently active. In this case, enter the *Services* menu and activate another set of service settings, see [Making a connection to a WAP service](#) on page 107. Try again to connect to the WAP page.

For the availability of different WAP services, pricing and tariffs, contact your network operator and/or the WAP service provider.

Note that when downloading a game, it may be saved in *Applications* menu instead of the *Games* menu.

Memory status for games

To view the size of memory available for game and application installations, press **Menu**, and select *Games* and *Memory*. See also [Memory status for applications](#) on page 94.

Game settings

Press **Menu**, and select *Games* and *Settings* to set sounds, lights and shakes for the game. You can save your Club Nokia membership number, *Club Nokia ID*. For



more information on Club Nokia and the game services, visit www.club.nokia.com. Availability may vary by country.

■ Applications (Menu 10)



WARNING: Do not switch the phone on when wireless phone use is prohibited or when it may cause interference or danger.

This menu allows the management of Java applications installed on your phone. Your phone software includes some Java applications specially designed for this Nokia phone. Various service providers offer other applications via WAP services. Before you can use one of these applications you have to download it to your phone.



Launching an application

1. Press **Menu**, and select *Applications* and *Select application*.
2. Scroll to an application or an application set (name depends on the application).
3. Press **Options** and select *Open* or press . If the selection is a single application it will be launched.

Otherwise, a list of applications in the selected application set is displayed. To launch a single application, scroll to the desired application and press **Options** and select *Open*, or press .





Tip: If an application uses the whole display area, no selection key names are displayed. Press the selection key  or  to show the options list. Then select one of the options or press **Back** to continue with the application.

Other options available for an application or application set

- **Delete** to delete the application or application set from the phone.
Note that if you delete a pre-installed application or an application set from your phone, you may download it back to your phone from the Nokia Software Market, www.softwamarket.nokia.com/wap or www.softwamarket.nokia.com/5100.
- **Web access** to restrict the application for accessing the network. Select **Ask first** and the phone asks for net access, **Allowed** to allow the net access, or **Not allowed** not to allow the net access.
- **Check version** to check if a new version of the application is available for download from the WAP services.
- **Web page** to provide further information or additional data for the application from an Internet page. This feature needs to be supported by the network. It is only shown if an Internet address has been provided with the application.
- **Details** to give additional information about the application.

Downloading an application

You can download new Java applications in different ways:



- Press **Menu**, and select *Applications* and *App. services* and the list of available WAP bookmarks is shown. Select *More bookmarks* to access the list of WAP bookmarks in the *Services* menu, see [Bookmarks](#) on page 111.

Select the appropriate bookmark to connect to the desired WAP page. If the connection fails, you may not be able to access the WAP page from the WAP service whose connection settings are currently active. In this case, enter the *Services* menu and activate another set of service settings, see [Making a connection to a WAP service](#) on page 107. Try again to connect to the WAP page.

For the availability of different WAP services, pricing and tariffs, contact your network operator and/or the WAP service provider.

- Press **Menu**, and select *Services* to find a WAP page to download an appropriate Java application. See [Browsing the pages of a WAP service](#) on page 108.
- Use the game download functionality, see [Game services](#) on page 90.
- Use the Java Application installer from PC Suite to download the applications in your phone.



Note that Nokia does not warrant for applications from non-Nokia sites. If you choose to download Java applications from them, you should take the same precautions, for security or content, as you would with any site.

Note that when downloading an application, it may be saved in *Games* menu instead of the *Applications* menu.



Memory status for applications

To view the size of memory available for game and application installations, press **Menu**, and select *Applications* and *Memory*.

■ Extras (Menu 11)

WARNING: Do not switch the phone on when wireless phone use is prohibited or when it may cause interference or danger.



Calculator

The calculator in your phone adds, subtracts, multiplies, divides, counts the square and the square root and converts currency values.

This calculator has a limited accuracy and rounding errors may occur, especially in long divisions.

1. Press **Menu**, and select *Extras* and *Calculator*.
2. When '0' is displayed on the screen, key in the first number in the calculation, press #[†] for a decimal point.
3. Press **Options** and select *Add, Subtract, Multiply, Divide, Square, Square root* or *Change sign*.

By selecting the option *Square, Square root* or *Change sign* you get the result and to proceed, select a further calculation.



Tip: Alternatively, press **+*** once to add, twice to subtract, three times to multiply or four times to divide.

4. Key in the second number.



5. For a total, press **Options** and select *Equals*. Repeat steps 3 to 5 as many times as is necessary.
6. To start a new calculation, just key in new numbers or first press and hold **Clear**.

Making a currency conversion

1. Press **Menu**, and select *Extras* and *Calculator*.
2. To save the exchange rate, press **Options** and select *Exchange rate*. Select either of the displayed options. Key in the exchange rate, press #⁰ for a decimal point, and press **OK**. The exchange rate remains in the memory until you replace it with another one.
3. To make the currency conversion, key in the amount to be converted, press **Options** and select *In domestic* or *In foreign*.



Tip: You can also make the currency conversion in standby mode by keying in the digits and then pressing **Options** and selecting either of the conversion types.

Countdown timer

The countdown timer allows you to enter a time value and it notifies you with an alarm when the time is up. There are two different timers in your phone, normal countdown timer and interval timer for counting cyclic time periods that can be useful for example during exercising.

Normal timing

1. Press **Menu**, and select *Extras - Countdown timer*.



2. Select *Normal timer*.
3. Key in the alarm time in format hh:mm:ss and press **OK**. If you wish, write your own note text shown when the time expires, and press **OK** to start the countdown timer.

To activate the timer in the standby mode, key in a number, press **Options** and select *Countdown timer* from the list and set the time.

To change the countdown time, select *Change time*, or to stop the timer, select *Stop timer* in Countdown timer view.

Adding a new interval timer

1. Press **Menu**, and select *Extras - Countdown timer - Interval timer*.
2. Select *Add new timer* if there are no formerly saved timers.
3. Key in the name for the timer.
4. Key in a name for the each period and set the timeframe for alarming.

You can set the progress to the next period to be either manual or automatic by selecting between the two options under *Extras-Countdown timer-Settings-Continue to the next period*.

Starting interval timer

1. Press **Menu**, and select *Extras - Countdown timer - Interval timer*.
2. Select the desired interval timer and select *Start timer*.
3. Select a stored period and press **Start**.



The interval timer starts running from the selected period. It continues from one period to another according to your choice in *Settings* submenu.

When the normal timer or a period of the interval timer expires, the phone sounds a tone, flashes lights and the note text. Stop the alarm by pressing any key. If no key is pressed, the alarm automatically stops within 30 seconds. To stop the alarm and to delete the note text, press **Quit**.

Stopwatch

You can measure time, take intermediate times or lap times using the stopwatch. During timing, the other functions of the phone can be used. To set the timing in the background, press .

Split timing

1. Select *Menu-Extras-Stopwatch-Split timing*.
2. Press **Start** and the clock starts running.

Note: If timing exceeds the value of 99:59:59:9, the time on the display changes to 00:00:00:0 and the clock keeps running.

3. Press **Stop** to finish the timing or **Splitto** to take an intermediate time.

Intermediate times can be viewed underneath the running time. When timing is stopped, the result is shown on the display.

If you restart the timing by pressing **Options -Start**, time keeps running cumulatively instead of restarting at zero. You can also save or reset timing using this options list.



Lap timing

1. Select *Menu-Extras-Stopwatch-Lap timing*.
2. Press **Start** and the clock starts running.
3. Press **Lap** when you want to see the lap time.

By pressing **Lap**, timing stops and then restarts immediately at zero. The newest lap time is displayed under the running time.

When you press **Stop** timing stops and the total time is shown.

Viewing times

You can see saved times by selecting *View times*. The named time sets are listed on the display. One time set can have up to 20 intermediate and lap times. To view them select a time set.

In this view to erase times, select *Options-Delete times*.

Deleting times

You can delete times by selecting *Delete times* from the Stopwatch main menu. The options are either erasing times one by one or all times at once. The deletion is confirmed by pressing **OK**.

Calorie counter

The calorie counter gives general estimations of energy costs in various physical activities. The energy cost depends on age, weight and gender. You can save up to 10 activities in your phone.



Saving personal data

1. Select *Extras-Calorie counter-Settings* and type in your weight and age and select your gender.
2. Press **OK** after each entry to save the data.

You can select the weight, calorie and velocity format by scrolling down the Settings menu and selecting the formats one by one.

Selecting an activity

1. Select *Extras-Calorie counter-Activities-Add new*.
2. Select an activity from the list and an intensity level to it, if available.
3. Add the duration of activity in format hh:mm and press **OK**.
The summary data with the energy cost is displayed.
4. Press **OK** to save the activity.

Editing and deleting activities

- To edit activities, press **Options** in *Activities* main view.
You can now add a new activity, edit an existing one, count the total calorie amount or delete an activity.
Tip: After you have made *Total calories* calculation you can make a calendar entry of the calorie consumption by selecting **Options-Save to calendar** and entering the date.
- To delete all activities at once, select *Extras-Calorie counter-Delete all* and press **OK**.



Thermometer

The thermometer measures the approximate temperature both in Celsius and Fahrenheit. You can also select whether the temperature value in the standby mode is shown or not.

1. Press **Menu** and select *Extras-Thermometer*.
2. Select either the option of showing or hiding the temperature value.

Note that to receive the best result, place the phone on a flat surface in a windless environment preferably for 5 minutes.

Note: If your phone is being charged, the radio or an active call is on, the thermometer shows no temperature.

Sound meter

The Sound meter can only measure the approximate level of the real dB level. The phone displays a vertical meter bar that shows the noise level graphically. There is also a numerical presentation of the sound level. The peak value is shown in a frame on the top and the current value is presented underneath.

Note: It is not possible to measure the estimated noise level of a call in progress. Also, you can not use Sound meter when a headset is connected.

When you press **Options** you get a list of four choices:

- With *Reset peak* you can reset the peak value.
- With *Hold peak* both values are shown but the peak value is updated only when the current noise level is greater than the peak value.



- With *Dynamic peak* both values are shown but the peak value is valid only for 5 seconds
- With *Noise tuning* you can simulate the sensitivity of hearing mechanism for different frequencies. You can choose between low noise (sounds < 85 dB) and loud noise (sounds > 85 dB).

■ Connectivity (Menu 12)



Infrared

WARNING: Do not switch the phone on when wireless phone use is prohibited or when it may cause interference or danger.

You can set up the phone to receive data through its infrared (IR) port. To use an IR connection, the device with which you want to establish a connection must be IrDA compliant. You can send or receive data such as business cards and calendar notes to or from a compatible phone or data device (for example, a computer) via the IR port of your phone.

Do not point the IR (infrared) beam at anyone's eye or allow it to interfere with other IR devices. This device is a Class 1 Laser product.

Sending and receiving data via IR

- Ensure that the IR ports of the sending and receiving devices are pointing at each other and that there are no obstructions between the devices. The preferable distance between the two devices in an infrared connection is one meter at most.



- To activate the IR port of your phone to receive data via IR, press **Menu**, and select *Connectivity* and *Infrared*.
- The user of the sending phone selects the desired IR function to start data transfer.

If data transfer is not started within two minutes after the activation of the IR port, the connection is cancelled and has to be started again.

IR connection indicator

- When **IR** is shown continuously, the IR connection is activated and your phone is ready to send or receive data via its IR port.
- When **IR** blinks, your phone is trying to connect to the other device or a connection has been lost.

GPRS

GPRS connection

You can set the phone to automatically register to a GPRS network when you switch the phone on. Press **Menu**, and select *Connectivity*, *GPRS*, *GPRS connection* and *Always online*. Starting a WAP or PC dial-up application, or sending/receiving multimedia messages creates the connection between phone and network and data transfer is possible. When you end the application, GPRS connection is ended but the registration to the GPRS network remains.

If you select *When needed*, the GPRS connection is established when an application needs it and closed when you end the application.



GPRS modem settings

You can connect the phone via infrared or data cable connection to a compatible PC and use the phone as a modem to enable GPRS connectivity from the PC.

Press **Menu**, and select *Connectivity*, *GPRS* and *GPRS modem settings*. Select *Active access point* and activate the access point you want to use. Select *Edit active access point* to change the access point settings.

- Scroll to *Alias for access point* and press **Select**. Key in the name you would like for the activated access point and press **OK**.
- Scroll to *GPRS access point* and press **Select**. Key in the Access Point Name (APN) and press **OK**.

An access point name is needed to establish a connection to a GPRS network. You can obtain the Access Point Name from your network operator or service provider.

You can also set the GPRS dial-up service settings (Access Point Name) on your PC by using the Nokia Modem Options software, see the Nokia website at www.nokia.com/support/phones/5100. If you have set the settings both on your PC and on your phone, note that the settings set on the PC will be used.

■ WAP services (Menu 13)

WARNING: Do not switch the phone on when wireless phone use is prohibited or when it may cause interference or danger.



You can access various WAP services such as banking, news, weather reports and flight times. These services are specially designed for mobile phones and they are



maintained by WAP service providers. Check the availability of WAP services, pricing and tariffs with your network operator and /or the service provider whose service you wish to use. Service providers will also give you instructions on how to use their services.

The WAP services use Wireless Mark-Up Language (WML) on their WAP pages. Internet web pages cannot be viewed on your phone.

Basic steps for accessing and using WAP services

1. Save the service settings that are needed to access the WAP service that you want to use. See page [110](#).
2. Make a connection to the given WAP service. See page [107](#).
3. Start browsing the pages of the WAP service. See page [108](#).
4. Once you are finished browsing, end the connection to the WAP service. See page [110](#).

Setting up the phone for a WAP service

You may receive the service settings as a text message from the network operator or service provider that offers the WAP service that you want to use. For more information, contact your network operator or service provider, or visit Club Nokia's website (www.club.nokia.com).

You can also key in the settings manually or add and edit the settings with PC Suite. For appropriate settings, contact your network operator or service provider. The WAP settings may be available, for example, on their website.



Saving the service settings received as a text message

When you receive the service settings as a text message, *Service settings received* is displayed.

- To save the received settings, press **View** and select **Save**.
If no settings are saved in *Active service settings*, the settings are saved under the first free connection set and also activated.
If there are settings saved in *Active service settings*, *Activate saved service settings?* will be displayed. To activate the saved settings, press **Yes**, or to save them only, press **No**.
- To discard the received settings, press **View** and select **Discard**.
- To view the received settings first, press **View** and select **View**. To save the settings, press **Save**.

Keying in the service settings manually

1. Press **Menu**, and select *Services*, and *Settings*.
2. Select *Active service settings*.

You need to activate the set where you want to save the service settings. A set is a collection of settings needed for making a connection to a WAP service.

3. Scroll to the set you would like to activate and press **Activate**.
4. Select *Edit active service settings*.

Select each of the following service settings one by one and key in all the required settings.

- *Settings' name* - Key in the new name for the connection set and press **OK**.



- *Homepage* - Key in the homepage address of the WAP service that you want to use, press **001** for a dot, and press **OK**.
- *Session mode* - Select *Permanent* or *Temporary*.
- *Connection security* - Select *On* or *Off*.
When the connection security is *On*, the phone tries to use a secure connection with the WAP service. If a secure connection is not available, the connection will not be made. If you wish to connect anyway, with a non-secure connection, you must set the connection security to *Off*.
- *Data bearer* - Select *GSM data* or *GPRS*. Settings for the selected bearer, see [Settings when GSM data is the selected data bearer](#) and [Settings when GPRS is the selected data bearer](#) below.
For pricing, connection speed and other information, contact your network operator or service provider.

Settings when GSM data is the selected data bearer

- *Dial-up number* - Key in the phone number and press **OK**.
- *IP address* - Key in the address, press **+*** for a dot, and press **OK**. You obtain the IP address from your network operator or service provider.
- *Authentication type* - Select *Secure* or *Normal*.
- *Data call type* - Select *Analogue* or *ISDN*.
- *Data call speed* - Select the speed you want to use, or select *Automatic*. *Automatic* is available only if the current selected data call type is *Analogue*. The actual data call speed depends on the service provider.



- *Login type* - Select *Manual* or *Automatic*.
- *User name* - Key in the user name and press **OK**.
- *Password* - Key in the password and press **OK**.

Settings when GPRS is the selected data bearer

- *GPRS access point* - Key in the access point name and press **OK**.
An access point name is needed to establish a connection to a GPRS network. You obtain the access point name from your network operator or service provider.
- *IP address* - Key in the address, press **+*** for a dot, and press **OK**. You obtain the IP address from your network operator or service provider.
- *Authentication type* - Select *Secure* or *Normal*. If you select *Automatic*, the login type uses the user name and password keyed in the following settings. If you select *Manual*, the login information is required when establishing a connection.
- *Login type* - Select *Manual* or *Automatic*.
- *User name* - Key in the user name and press **OK**.
- *Password* - Key in the password and press **OK**.

Making a connection to a WAP service

Firstly, make sure that the service settings of the WAP service you want to use are activated. To activate the settings:



- Press **Menu**, and select *Services* and *Settings*. Select *Active service settings* and scroll to the set you want to activate and press **Activate**.

Secondly, make a connection to the WAP service. There are three ways to connect:

1. Open the homepage of the WAP service:

Press **Menu**, and select *Services* and *Home*.



Tip: To quickly open the homepage of a WAP service, press and hold  in standby mode.

2. Select a bookmark of the WAP service:

Press **Menu**, and select *Services*, *Bookmarks*, and select a bookmark.

If the bookmark does not work with the current active service settings, activate another set of service settings and try again.

3. Key in the address of the WAP service:

Press **Menu**, and select *Services* and then *Go to address*. Key in the address of the WAP service, press **+*** for special characters, and press **OK**.

Note that it is not necessary to add the prefix `http://` in front of the address since it will be added automatically.







Browsing the pages of a WAP service

After you have made a connection to the WAP service, you can start browsing its WAP pages. The function of the phone keys may vary in different WAP services. Follow the text guides on the phone display. For more information, contact your WAP service provider.



Note that if GPRS is selected as the data bearer, the indicator **G** is shown on the top left of the display during browsing. If you receive or make a call during a GPRS connection, the indicator **E** will be shown on the top right of the display to indicate that the GPRS connection is on hold.

Using the phone keys while browsing

- Use the scroll keys  or  to browse the WAP page.
- To select a highlighted item, press .
- To enter letters and numbers, press the keys  -  and to enter special characters, press the key .

Options while browsing

Press **Options** and select one of the options available. The service provider may also offer other options. Select

- *Home* to go back to the homepage of the WAP service.
- *Bookmarks*. See page 111.
- *Call / Edit / Open row / Open link / Open list* to call, to key in text or to select a highlighted item on the WAP page.
- *Add bookmark* to save the WAP page as a bookmark.
- *View image* to view images and animations from the WAP page.
- *Go to address* to key in the address of the WAP service you want to access.
- *Service inbox*. See page 112.
- *Appear. settings*. See details on page 110.





- *Cookie settings*. See page 111.
- *Use number* to copy a number from the WAP page for saving or making a call. If the WAP page contains several numbers, you may select the desired one.
- *Reload* to reload and update the current WAP page.
- *Clear the cache*. See [The cache memory](#) on page 113.
- *Security info* to view security information about the current WAP connection and the server.
- *Quit*. See [Ending a WAP connection](#) on page 110.

Direct calling

The WAP browser supports functions which you can access while browsing. You can make a voice call, send DTMF tones while a voice call is in progress, and save a name and a phone number from a WAP page.

Ending a WAP connection

To quit browsing and to end the connection, press **Options** and select *Quit*. When *Quit browsing?* is shown, press **Yes**.

Alternatively, press . If *GSM data* is the selected data bearer, press  twice. The phone ends the connection to the WAP service.

Appearance settings of WAP browser

1. While browsing, press **Options** and select *Appear. settings*, or in standby mode, press **Menu**, and select *Services, Settings* and *Appearance settings*.



2. Select *Text wrapping* or *Show images*.
3. Select *On* or *Off* for *Text wrapping* and *Yes* or *No* for *Show images*.

When *Text wrapping* is set to *On*, the text continues on the next line if it cannot be shown on one line. If you select *Off*, the text is abbreviated if it is too long to be shown on one line.

When *Show images* is set to *No*, any pictures appearing on the WAP page are not shown. This can speed up the browsing of WAP pages that contain a lot of pictures.

Cookie settings

You can set the phone to allow or prevent receiving cookies. A cookie is data that a WAP site saves in your phone's browser cache memory. The data can be, for example, your user information or your browsing preferences. Cookies will be saved until you clear the cache memory, see [The cache memory](#) on page 113.

1. While browsing, press **Options** and select *Cookie settings*, or in standby mode, press **Menu**, and select *Services*, *Settings* and *Cookie settings*.
2. Select *Cookies* and select *Allow* or *Reject* to allow or prevent the phone receiving cookies.

Bookmarks

You can save up to 50 WAP page addresses as bookmarks in the phone's memory.

1. While browsing, press **Options** and select *Bookmarks*, or in standby mode, press **Menu**, and select *Services* and *Bookmarks*.



2. Scroll to the bookmark you want to use and press **Options**.
3. Select one of the following options:
 - Go to* to make a connection to the WAP page associated with the bookmark.
 - Edit* or *Delete* to modify or delete the selected bookmark.
 - Send* to send the selected bookmark directly to another phone select *As bookmark*, or to send it as a text message, select *As text message*.
 - New bookmark* to create a new bookmark without connection to the WAP service. Key in the address and the title of the WAP page and press **OK**.

Note that your phone may have some pre-installed bookmarks for sites not affiliated with Nokia. Nokia does not warrant or endorse these sites. If you choose to access them, you should take the same precautions, for security or content, as you would with any Internet site, for example.

Receiving a bookmark

When you have received a bookmark as a text message, press **Options** and select *View*, *Save*, or *Discard*.

Service inbox

The phone is able to receive service messages (pushed messages) sent by your service provider. Service messages are notifications of, for example, news headlines, and they may contain a text message or address of a WAP service.

To access the *Service inbox* in standby mode, when you have received a service message, press **View**.



- If you press **Exit** the message is moved to the *Service inbox*. To access the *Service inbox* later, press **Menu**, and select *Services*, and *Service inbox*.

To access the *Service inbox* while browsing, press **Options** and select *Service inbox*. Scroll to the message you want, press **Options** and select

- *Retrieve* to activate the WML browser and download the indicated content.
- *Details* to display detailed information on the service notification.
- *Delete* to delete the selected service notification.

To set the phone to receive service messages

Press **Menu**, and select *Services*, *Settings*, *Service inbox settings*, and *Service messages*. To set the phone to receive service messages, select *On*. If you select *Off*, the phone will not receive service messages.

The cache memory



Note: The information or services you have accessed are stored in the cache of your phone. A cache is a buffer memory, which is used to store data temporarily. If you have tried to access or have accessed confidential information requiring passwords (for example, your bank account), empty the cache of your phone after each use.

To empty the cache,

- while browsing, press **Options** and select *Clear the cache*, or
- in standby mode, press **Menu**, and select *Services*, and *Clear the cache*.



Authority certificates

For using some WAP services, such as banking services, you need security certificates. Using the certificates can help you improve the security of connections between your phone and a WAP gateway or WAP server, if the *Connection security* is set to *On*.

You can download an authority certificate from a WAP page, if the WAP service supports the use of authority certificates. After the download, you can view the certificate and then save or delete it. If you save the certificate, it is added to the certificate list in the phone.

The phone indicates if the identity of the WAP server or WAP gateway cannot be verified, if the WAP server or WAP gateway certificate is not authentic or if you do not have the correct authority certificate in your phone.

Viewing the list of authority certificates

Press **Menu**, select *Services*, and *Settings*. Select *Authority certificates*.

See also *Security info* in *Options while browsing* on page 109.

Security indicator

The security indicator  is displayed during a WAP connection, if the data transmission between the phone and the WAP gateway or WAP server (identified by the *IP address* in the *Edit active service settings*) is encrypted. It is up to the service provider to secure the data transmission between the gateway and the content server.



■ SIM services (Menu 14)



In addition to the functions available on the phone, your SIM card may provide additional services that you can access in menu 14. Menu 14 is shown only if it is supported by your SIM card. The name and contents of the menu depend entirely on the service available.



Note: For availability, rates and information on using SIM services, contact your SIM card vendor, e.g. network operator, service provider or other vendor.

You can set the phone to show you the confirmation messages sent between your phone and the network when you are using the SIM services by selecting the option *Yes* within the menu *Confirm SIM service actions*, menu 4-3-6.

Note that accessing these services may involve sending a text message (SMS) or making a phone call for which you may be charged.



7. Battery information

■ Charging and Discharging

Your phone is powered by a rechargeable battery.

Note that a new battery's full performance is achieved only after two or three complete charge and discharge cycles!

The battery can be charged and discharged hundreds of times but it will eventually wear out. When the operating time (talk-time and standby time) is noticeably shorter than normal, it is time to buy a new battery.

Use only batteries approved by the phone manufacturer and recharge your battery only with the chargers approved by the manufacturer. Unplug the charger when not in use. Do not leave the battery connected to a charger for longer than a week, since overcharging may shorten its lifetime. If left unused a fully charged battery will discharge itself over time.

Temperature extremes can affect the ability of your battery to charge.

Use the battery only for its intended purpose.

Never use any charger or battery which is damaged.

Do not short-circuit the battery. Accidental short-circuiting can occur when a metallic object (e.g.coin, clip or pen) causes direct connection of the + and - terminals of the battery (metal strips on the battery) for example when you carry a spare battery in your pocket or purse. Short-circuiting the terminals may damage the battery or the connecting object.

Leaving the battery in hot or cold places, such as in a closed car in summer or winter conditions, will reduce the capacity and lifetime of the battery. Always try to keep the



battery between 15°C and 25°C (59°F and 77°F). A phone with a hot or cold battery may temporarily not work, even when the battery is fully charged. Batteries' performance is particularly limited in temperatures well below freezing.

Do not dispose of batteries in a fire !

Dispose of batteries according to local regulations (e.g. recycling). Do not dispose as household waste.



CARE AND MAINTENANCE

Your phone is a product of superior design and craftsmanship and should be treated with care. Although it has been designed for an active lifestyle, (so it has an improved protection against water, dust, shocks and scratches) the suggestions below will help you to fulfil any warranty obligations and to enjoy this product for many years.

- Keep the phone and all its parts and accessories out of the reach of small children.
- Keep the phone dry. Precipitation, humidity and all types of liquids or moisture can contain minerals that will corrode electronic circuits.
- Do not use or store the phone in dusty, dirty areas. Its moving parts can be damaged.
- Do not store the phone in hot areas. High temperatures can shorten the life of electronic devices, damage batteries, and warp or melt certain plastics.
- Do not store the phone in cold areas. When it warms up (to its normal temperature), moisture can form inside, which may damage electronic circuit boards.
- Do not attempt to open the phone. Non-expert handling may damage it.
- Do not drop, knock or shake the phone. Rough handling can break internal circuit boards.
- Do not use harsh chemicals, cleaning solvents, or strong detergents to clean the phone.
- Do not paint the phone. Paint can clog the moving parts and prevent proper operation.
- Use only the supplied or an approved replacement antenna. Unauthorised antennas, modifications or attachments could damage the phone and may violate regulations governing radio devices.

All of the above suggestions apply equally to your phone, battery, charger or any accessory. If any of them is not working properly, take it to your nearest qualified service facility. The personnel there will assist you and, if necessary, arrange for service.



IMPORTANT SAFETY INFORMATION

■ Traffic Safety

Do not use a hand-held telephone while driving a vehicle. Always secure the phone in its holder; do not place the phone on the passenger seat or where it can break loose in a collision or sudden stop.

Remember road safety always comes first!

■ Operating environment

Remember to follow any special regulations in force in any area and always switch off your phone whenever it is forbidden to use it, or when it may cause interference or danger.

Use the phone only in its normal operating positions.

Parts of the phone are magnetic. Metallic materials may be attracted to the phone, and persons with a hearing aid should not hold the phone to the ear with the hearing aid. Always secure the phone in its holder, because metallic materials may be attracted by the earpiece. Do not place credit cards or other magnetic storage media near the phone, because information stored on them may be erased.

■ Electronic devices

Most modern electronic equipment is shielded from radio frequency (RF) signals. However, certain electronic equipment may not be shielded against the RF signals from your wireless phone.



Pacemakers

Pacemaker manufacturers recommend that a minimum separation of 20 cm (6 inches) be maintained between a handheld wireless phone and a pacemaker to avoid potential interference with the pacemaker. These recommendations are consistent with the independent research by and recommendations of Wireless Technology Research. Persons with pacemakers:

- Should always keep the phone more than 20 cm (6 inches) from their pacemaker when the phone is switched on;
- Should not carry the phone in a breast pocket;
- Should use the ear opposite the pacemaker to minimise the potential for interference.
- If you have any reason to suspect that interference is taking place, switch off your phone immediately.

Hearing aids

Some digital wireless phones may interfere with some hearing aids. In the event of such interference, you may want to consult your service provider.

Other medical devices

Operation of any radio transmitting equipment, including cellular phones, may interfere with the functionality of inadequately protected medical devices. Consult a physician or the manufacturer of the medical device to determine if they are adequately shielded from external RF energy or if you have any questions. Switch off your phone in health care facilities when any regulations posted in these areas instruct you to do so. Hospitals or health care facilities may be using equipment that could be sensitive to external RF energy.



Vehicles

RF signals may affect improperly installed or inadequately shielded electronic systems in motor vehicles (e.g. electronic fuel injection systems, electronic anti-skid (anti-lock) braking systems, electronic speed control systems, air bag systems). Check with the manufacturer or its representative regarding your vehicle. You should also consult the manufacturer of any equipment that has been added to your vehicle.

Posted facilities

Switch your phone off in any facility where posted notices so require.

■ Potentially explosive atmospheres

Switch off your phone when in any area with a potentially explosive atmosphere and obey all signs and instructions. Sparks in such areas could cause an explosion or fire resulting in bodily injury or even death.

Users are advised to switch off the phone when at a refuelling point (service station). Users are reminded of the need to observe restrictions on the use of radio equipment in fuel depots (fuel storage and distribution areas), chemical plants or where blasting operations are in progress.

Areas with a potentially explosive atmosphere are often but not always clearly marked. They include below deck on boats; chemical transfer or storage facilities; vehicles using liquified petroleum gas (such as propane or butane); areas where the air contains chemicals or particles, such as grain, dust or metal powders; and any other area where you would normally be advised to turn off your vehicle engine.



■ Vehicles

Only qualified personnel should service the phone, or install the phone in a vehicle. Faulty installation or service may be dangerous and may invalidate any warranty which may apply to the unit.

Check regularly that all wireless phone equipment in your vehicle is mounted and operating properly.

Do not store or carry flammable liquids, gases or explosive materials in the same compartment as the phone, its parts or accessories.

For vehicles equipped with an air bag, remember that an air bag inflates with great force. Do not place objects, including both installed or portable wireless equipment in the area over the air bag or in the air bag deployment area. If in-vehicle wireless equipment is improperly installed and the air bag inflates, serious injury could result.

Using your phone while in the air is prohibited. Switch off your phone before boarding an aircraft. The use of wireless telephones in an aircraft may be dangerous to the operation of the aircraft, disrupt the wireless telephone network and may be illegal.

Failure to observe these instructions may lead to suspension or denial of telephone services to the offender, or legal action or both.

■ Emergency calls



Important:

This phone, like any wireless phone, operates using radio signals, wireless and landline networks as well as user-programmed functions. Because of this, connections in all conditions can not be guaranteed. Therefore you should never rely solely upon any wireless phone for essential communications (e.g. medical emergencies).

Emergency calls may not be possible on all wireless phone networks or when certain network services and/or phone features are in use. Check with local service providers.



To make an emergency call:

1. If the phone is not on, switch it on. Check for adequate signal strength.
Some networks may require that a valid SIM card is properly inserted in the phone.
2. Press  as many times as needed (e.g. to exit a call, to exit a menu, etc.) to clear the display and ready the phone for calls.
3. Key in the emergency number for your present location (e.g. 112 or other official emergency number). Emergency numbers vary by location.
4. Press the  key.

If certain features are in use, you may first need to turn those features off before you can make an emergency call. Consult this guide and your local cellular service provider.

When making an emergency call, remember to give all the necessary information as accurately as possible. Remember that your wireless phone may be the only means of communication at the scene of an accident - do not cut off the call until given permission to do so.

■ Certification information (SAR)

THIS MODEL PHONE MEETS THE EU REQUIREMENTS FOR EXPOSURE TO RADIO WAVES.

Your mobile phone is a radio transmitter and receiver. It is designed and manufactured not to exceed the limits for exposure to radiofrequency (RF) energy recommended by The Council of the European Union. These limits are part of comprehensive guidelines and establish permitted levels of RF energy for the general population. The guidelines were developed by independent scientific organisations through periodic and thorough evaluation of scientific studies. The limits include a substantial safety margin designed to assure the safety of all persons, regardless of age and health.

The exposure standard for mobile phones employs a unit of measurement known as the Specific Absorption Rate, or SAR. The SAR limit recommended by The Council of the



European Union is 2.0 W/kg.* Tests for SAR have been conducted using standard operating positions with the phone transmitting at its highest certified power level in all tested frequency bands. Although the SAR is determined at the highest certified power level, the actual SAR level of the phone while operating can be well below the maximum value. This is because the phone is designed to operate at multiple power levels so as to use only the power required to reach the network. In general, the closer you are to a base station antenna, the lower the power output.

Before a phone model is available for sale to the public, compliance with the European R&TTE directive must be shown. This directive includes as one essential requirement the protection of the health and the safety for the user and any other person. The highest SAR value for this model phone when tested for compliance against the standard was 0.48 W/kg. While there may be differences between the SAR levels of various phones and at various positions, they all meet the EU requirements for RF exposure.

* The SAR limit for mobile phones used by the public is 2.0 watts/kilogram (W/kg) averaged over ten grams of tissue. The limit incorporates a substantial margin of safety to give additional protection for the public and to account for any variations in measurements. SAR values may vary depending on national reporting requirements and the network band. For SAR information in other regions please look under product information at www.nokia.com.



LIMITED MANUFACTURER'S WARRANTY

PART OF EUROPE & AFRICA REGION

This limited warranty shall apply in part of Nokia Mobile Phones' Europe & Africa Region unless a local warranty exists. Nokia Corporation, Nokia Mobile Phones ("Nokia") warrants that this NOKIA product ("Product") is at the time of its original purchase free of defects in materials, design and workmanship subject to the following terms and conditions:

1. This limited warranty is given to the end-purchaser of the Product ("Customer"). It shall neither exclude nor limit i) any mandatory statutory rights of the Customer or ii) any of the Customer's rights against the seller/dealer of the Product.
2. The warranty period is twelve (12) months from the date on which the first Customer purchased the Product. In case of a subsequent purchase or other change of owner/user, such warranty period shall continue for the remaining part of the twelve (12) month period and otherwise remain unaffected. This limited warranty is only valid and enforceable in the following countries: Bosnia, Bulgaria, Croatia, Cyprus, the Czech Republic, Estonia, any member state of the European Union, Hungary, Iceland, Israel, Latvia, Lithuania, Macedonia, Malta, Norway, Poland, Romania, the Slovak Republic, Slovenia, Switzerland and Turkey.
3. During the warranty period Nokia or its authorized service company will repair or replace, at Nokia's sole discretion, a defective Product. Nokia will return the repaired Product or another Product to the Customer in good working condition. All parts or other equipment for which replacements have been provided shall become the property of Nokia.
4. A repaired or replaced Product will not be given a prolonged or renewed warranty period.
5. This limited warranty will not cover painted covers or other similar personalized parts. In all cases that require unlocking or locking of an operator SIM-lock, Nokia will first direct the Customer to such operator for unlocking or locking of the operator SIM-lock before repairing or replacing the Product.
6. This limited warranty shall not apply to deterioration due to normal wear and tear. This limited warranty shall further not apply if:

(i) the defect was caused by the fact that the Product has been subjected to: use in contradiction with the owner's/user manual, rough handling, exposure to moisture, dampness or extreme thermal or environmental conditions or rapid changes in such conditions, corrosion, oxidation, unauthorized modifications or connections, unauthorized opening or repair, repair by use of unauthorized spare parts, misuse, improper installation, accident, forces of nature, spillage of food or liquid, influence from chemical products or other acts beyond the reasonable control of Nokia (including but not limited to deficiencies in consumable parts, such as batteries

which all by their nature have a limited lifetime, and breakage or damage to antennas) unless the defect was caused directly by defects in materials, design or workmanship;

- (ii) Nokia or its authorized service company was not notified by the Customer of the defect within thirty (30) days after the appearance of the defect within the warranty period;
 - (iii) the Product was not returned to Nokia or its authorized service company within thirty (30) days after the appearance of the defect within the warranty period;
 - (iv) the Product serial number, the accessory date code or the IMEI number has been removed, erased, defaced, altered or is illegible;
 - (v) the defect was caused by a defective function of the cellular network;
 - (vi) the defect was caused by the fact that the Product was used with or connected to an accessory not manufactured and supplied by Nokia or used in other than its intended use;
 - (vii) the defect was caused by the fact that the battery was short-circuited or seals of the battery enclosure or cells were broken or show evidence of tampering or the battery was used in equipment other than for which it has been specified; or
 - (viii) the Product software needs to be upgraded due to changes in cellular network parameters.
7. To claim this limited warranty the Customer shall present either i) a legible and non-modified original warranty card which clearly indicates the name and address of the seller, the date and place of purchase, the product type and the IMEI or other serial number or alternatively ii) a legible and non-modified original purchase receipt which contains the same information, if such purchase receipt is presented to the seller/dealer of the Product.
 8. This limited warranty is the Customer's sole and exclusive remedy against Nokia and Nokia's sole and exclusive liability against the Customer for defects or malfunctions of the Product. This limited warranty replaces all other warranties and liabilities, whether oral, written, (non-mandatory) statutory, contractual, in tort or otherwise. Nokia is in no event liable for any incidental, consequential or indirect damage, costs or expenses. Neither is Nokia in any event liable for any direct damage, costs or expenses, if the Customer is a legal person.
 9. Any change or amendment to this limited warranty requires Nokia's prior written consent.

WARRANTY CARD

FILL IN WITH BLOCK LETTERS

Purchaser's Name: _____

Address: _____

Country: _____

Phone: _____

Date of Purchase (dd/mm/yy): [] [] / [] [] / [] []

Product Type (on phone type label under battery): [] [] [] - [] [] []

Product Model (on phone type label under battery): [] [] [] []

Phone Serial No (on phone type label under battery):

[] [] [] [] [] [] / [] [] / [] [] [] [] [] [] [] [] [] [] [] [] [] []

Place of Purchase: _____

Store Name: _____

Store Address: _____

 ITEM: IMEI:	<div style="border: 1px solid black; width: 30px; height: 30px; margin: 0 auto; display: flex; align-items: center; justify-content: center;">B</div>
---	---

Stamp