

Contents

R520	5	Phone Book	34
Preparing Your Phone	6	Saving Contacts	34
Assembly	7	Calling a Contact	35
SIM Card	7	Editing the Phone Book	36
Battery	7	Copy to and from the SIM Card ..	37
The Clip	10	Business Cards	38
Making Calls	11	Groups	39
Turning Your Phone On	11	Touch Tone Services	40
Making a Call	11	Checking the Memory	41
Receiving a Call	14	Text Messages	42
Turning Your Phone Off	14	Before Sending Messages	42
During a Call	15	Sending Messages	44
Earpiece Volume	15	Status Report	45
Microphone	15	Receiving Messages	46
Speakerphone	15	List of Options	46
Notepad	16	Area Information	48
Sending Touch Tone Signals	16	Bluetooth™	
Ciphering	16	Wireless Technology	49
Key Functions	17	Before You Start	49
Menus	19	Operation Modes	51
Moving through the Menus	19	Searching for Devices	52
Instructions	19	Sending and Receiving	52
Display Text	20	Infrared Port	54
Help Texts	21	Activating the IR Port	54
Menu Language	21	Connecting IR Devices	55
My Shortcuts	21	Calendar	56
Personalizing		Appointments and Tasks	56
Your Phone	23	Viewing Your Calendar	57
Sounds	23	Editing and Deleting	58
Display	26	The List of Options	58
Time Settings	28	Calendar Settings	59
Master Reset	29	Exchanging Calendar Entries	59
Entering Letters	30	Synchronization	61
Input Languages	30	Starting the Synchronization	61
Multitap Text Input	30	Setting up WAP	62
T9® Text Input	32	Data Account Settings	62
		WAP Profile Settings	64
		WAP	67
		Starting the WAP Browser	67
		Exiting the WAP Browser	67
		Options When Browsing	68

Additional WAP Options	68	Call Time and Call Cost	91
Security	69	Checking the Time or Cost	91
WAP Push Messages	70	Setting the Call Cost	91
Data Calls	71	Credit Limit for Calls	92
Sending Data Calls	71	Minute Minder	92
Receiving Data Calls	71	Networks	93
Sending and Receiving E-mail from Your PC	72	Searching for Networks	93
Profiles	73	Preferred Networks	93
Selecting a Profile	73	Search Modes	94
Changing the Profile Settings	74	Security	96
Accessories	74	Locking the SIM Card	96
Voice Control	76	Locking the Phone	97
Before Voice Dialling	76	Locking the Keypad	97
Voice Dialling	77	Restricting Calls	98
Voice Answering	77	Fixed Dialling	99
Changing Profiles	78	Closed User Groups	99
Recording Voice Memos	78	Accepting Calls	100
The Magic Word	79	Code Memo	101
Editing Your Voice Commands	80	Checkword and Security	101
Voice Memo	81	Using Code Memo	101
Recording Voice Memos	81	Deleting and Editing Codes	102
Listening to Voice Memos	82	Changing the Password	102
Editing Voice Memos	82	Forgot Your Password?	102
Recording Quality	82	Two Voice Lines	103
Settings	83	Changing the Name	103
Voice Mail Service	84	Changing Lines	103
Calling Your Voice Mail	84	Locking One Line	104
Message Alert Signal	84	Calling Card Calls	105
Diverting Calls	85	Calling Card Service	105
Activating Divert Calls	85	Saving Calling Card Numbers	105
Cancelling Divert Calls	86	Choosing a Card	106
Checking Divert Status	86	Making a Calling Card Call	106
More than One Call	87	Games	107
Call Waiting Service	87	Tennis	107
Making a Second Call	87	Erix	108
Receiving a Second Call	88	Tools	109
Handling Two Calls	88	Alarm Clock	109
Receiving a Third Call	89	Stopwatch	110
Conference Calls	89	Timer	111
		Calculator	111

Online Services	112	Limited Warranty	126
Ericsson Mobile Internet	113	Regulatory Information	129
Troubleshooting	114	Icons	131
Error Messages	114	Quick Keys	135
Other Problems	115	Index	139
Technical Data	117		
Safe and Efficient Use	119		

Ericsson R520

Second edition (February 2001)

This User's Guide is published by Ericsson Mobile Communications AB, without any warranty. Improvements and changes to this User's Guide necessitated by typographical errors, inaccuracies of current information, or improvements to programs and/or equipment, may be made by Ericsson Mobile Communications AB at any time and without notice. Such changes will, however, be incorporated into new editions of this User's Guide.

All rights reserved.

©Ericsson Mobile Communications AB, 2001

Publication number: EN/LZT 108 4268 R2A

INNOVATRON PATENTS

Please note:

Some of the services described in this User's Guide are not supported by all networks. Such services are indicated by an icon in the left margin. *This also applies to the GSM International Emergency Numbers.*

Please contact your network operator or service provider if you are in doubt whether you can use a particular service or not.

Please read the *Safe and Efficient Use* and the *Warranty* chapters before using your mobile phone.

The BLUETOOTH trademarks are owned by Telefonaktiebolaget L M Ericsson, Sweden.

T9 is a registered trademark of Tegic Communications.

T9 is licensed under one or more of the following: U.S. Pat. Nos. 5,818,437, 5,953,541, 5,187,480, 5,945,928, and 6,011,554; Canadian Pat. No. 1,331,057; United Kingdom Pat. No. 2238414B; Hong Kong Standard Pat. No.

HK0940329; Republic of Singapore Pat. No. 51383; Euro. Pat. No. 0 842 463(96927260.8) DE/DK, FI, FR, IT, NL, PT, ES, SE, GB; and additional patents are pending worldwide.

R520

Your R520 is a **Triple Band** phone (GSM 900/1800/1900), which means that you can use it almost all over the world. It contains a whole new set of functions helping you to be more efficient and productive, no matter where you are.

The R520 supports **GPRS** (General Packet Radio Services), which means data is sent in packages at a very high speed. This is of great advantage when using the **WAP** browser, for example, since you can be connected all the time, yet pay only for the amount of data that you download. **HSCSD** (High Speed Circuit Switched Data) is yet another feature which enables faster data connections.

The R520 offers built-in **Bluetooth™** wireless technology. Short-range radio links make it possible for you to connect your phone wirelessly to other *Bluetooth* devices such as a headset, PC, PDA, printer and so on. You can synchronize meetings and contacts in your phone and your PC.

The advanced **Calendar** helps you to keep track of your meetings. You can create a phone book of **Contacts** in which you can save multiple numbers and voice labels for each person. You can write text messages more quickly and easily by using the **T9 Text Input**. The advanced **Voice Control** enables completely handsfree communication, using the **Magic Word** function. The **Speakerphone** is another handsfree alternative.

Preparing Your Phone

Front

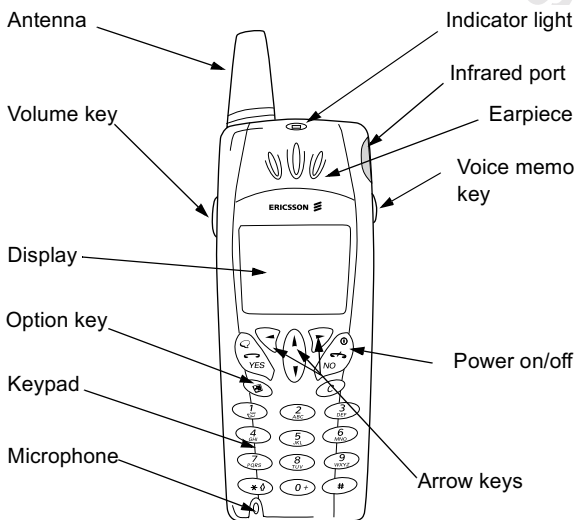

Back

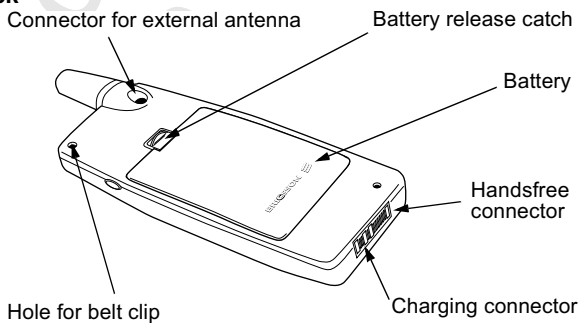

Assembly

You need to do the following to use your phone:

- insert the SIM card.
- attach and charge the battery.

SIM Card

Your network operator provides you with a SIM (Subscriber Identity Module) card. The SIM card contains information about your phone number, the services included in your subscription, and your phone book, among other things.

Note: *Turn off the phone and disconnect the charger and other accessories before you insert or remove your SIM card.*

Inserting and Removing the SIM Card

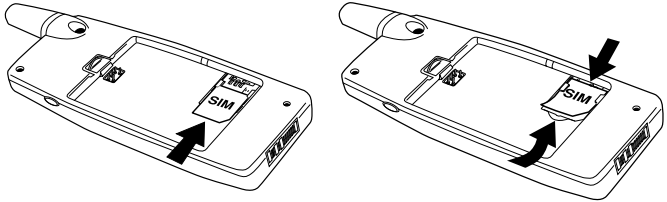

1. Remove the battery if attached. Slide the SIM card into the slot, under the silvery holders, with the golden connectors facing down.
2. To remove it, raise the edge of the SIM card and slide it out.

Battery

Your phone comes with a lithium battery. The battery is not charged when you buy your phone, but there may be enough power to turn the phone on.

Attaching the Battery

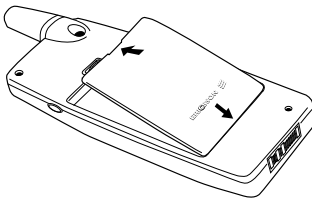

- Place the battery on the back of the phone and push until you hear a click.

When to Charge the Battery

You can charge the battery that comes with your phone whenever you wish, without its performance being affected. You can also charge the battery when the phone is off. To remind you that you will soon need to charge the battery or replace it with a charged one:

- an alarm signal (a short beep) sounds and **Attention! Battery low** appears in the display.
- the indicator light on top of the phone starts flashing red.

With an Ericsson-approved battery, you can check the remaining talk time and standby time in the **Status** menu by sliding the volume key up or down in standby mode. The total remaining talk time and standby time may vary, depending on network conditions. Please note that these times are approximate and that you may have 10% less time than is shown in the display.

Charging the Battery

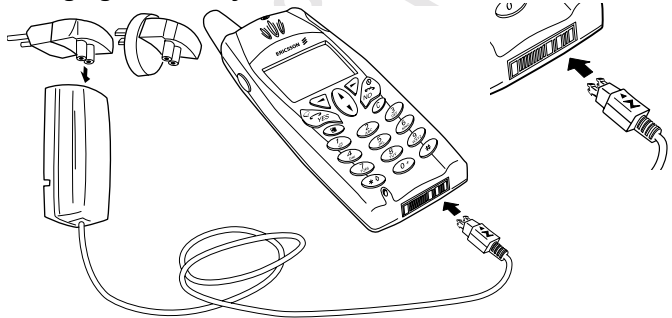

1. Make sure that the battery is attached to the phone.
2. Connect the charger to the mains.
3. Connect the charger to the phone as shown. The flash symbol on the plug must face upwards.

Note: *The mains plug may look different depending on the mains socket in your country. Do not connect it to any item other than your Ericsson Travel Charger CTR-10. Do not separate the charger from the plug when plugged into the mains socket.*

To indicate charging:

- the battery meter in the display pulses continuously.
- the indicator on top of the phone shows a steady red light (or green, if the phone is switched on).
- **Optimized charging** is shown briefly in the display.



Note: *It may take several minutes before you get an indication of charging in the display, if you charge a new battery that is empty, or a battery that has not been used for a long time.*

When the battery is fully charged, the battery meter in the display is full and the indicator on top of the phone shows a steady green light.

For the best charging, talk and standby times in the long run, we recommend that you use only Ericsson-approved batteries with your phone.

Disconnecting the Charger

Tilt the plug up.

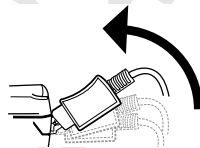

Removing the Battery

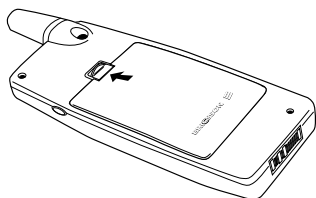

1. Slide the release catch up.

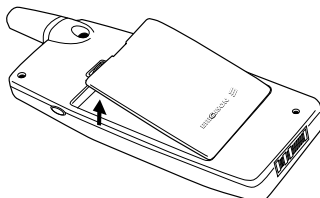

2. Lift the battery away from the phone.

The Clip

By using the clip with your phone, you can hang your phone, for example, on your trousers or shirt.

To use the clip with your phone

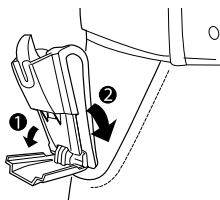

1. Open the clip and slide it down.

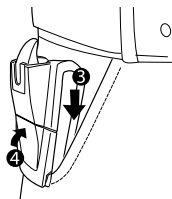

2. Close the clip to attach it.



3. Remove the rubber plug.

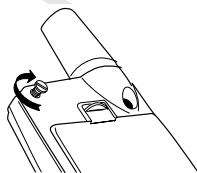

4. Insert and fasten the screw.

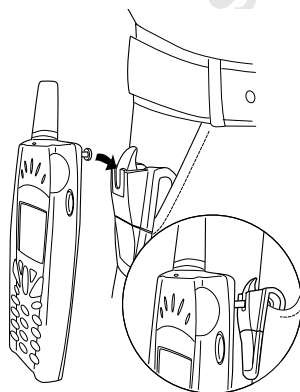

5. Slide the phone into the clip until you hear a click.

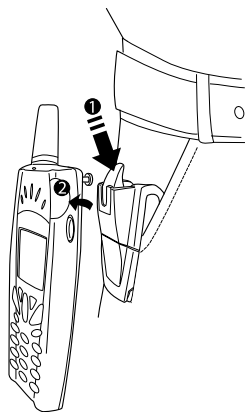

6. Press the release catch and move the phone up to detach it from the clip.

Making Calls

Before you can make and receive calls, you need to turn on the phone and be within range of a network.

Turning Your Phone On

- Press and hold the **NO** key until you hear a tone.

The PIN

Most SIM cards are protected with a PIN (Personal Identity Number), which you get from your network operator and which you need in order to access the network. If **PIN:** appears in the display after you have turned on the phone:

1. Enter your PIN. If you make a mistake while entering your PIN, delete the wrong number by pressing .
2. Press **YES**.

If your PIN is entered incorrectly three times in a row, the SIM card is blocked. If this happens, you can unblock it by using your PUK (Personal Unblocking Key), which you also get from your network operator. See “Locking the SIM Card” on page 96.

If **Phone locked** appears in the display, enter your phone lock code. See “Locking the Phone” on page 97.

Network Search

After you have turned on the phone (and entered your PIN), the phone searches for a network. When a network is found, the phone beeps three times. The indicator light on top of the phone flashes green and your network operator’s name (in most cases abbreviated) appears in the display. This is called standby mode. You can now make and receive calls.

Note: *If you do not reach standby mode, see “Error Messages” on page 114 or “Searching for Networks” on page 93.*

Making a Call

1. Enter the area code and phone number (note that some countries may not use area codes).
You can edit the number before calling by pressing .
2. Press **YES**.

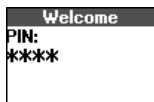



3. Press **NO** to end the call.

Using the Call List

The numbers that you have dialled are always saved in the **Call list**. If your subscription includes the Calling Line Identification (CLI) service and the caller's network sends the number, you will also find the numbers (together with a name if saved in your phone book) of answered and missed calls in the call list. If the incoming call is a restricted number, the display shows **Withheld**. If the incoming call is an unknown number, the display shows **Unknown**.

You can delete a number by pressing **(C)**, **YES**.

The call list saves:

	Dialled numbers
	Answered calls
	Missed calls

The last 30 incoming and outgoing calls are saved together in chronological order. The last call made is saved in first position. If the same number is called more than once, the latest call replaces earlier ones. If you check a call within 24 hours, the time of the call is displayed. Otherwise, the time is replaced by the date.

To call a number from the call list

1. Press **YES** from standby mode.
2. Press **(v)** or **(^)** until the number you want to call is highlighted. You can edit the number before calling by pressing **(#)**.
3. Press **YES**.

Note: *You can also find the Call list in the Call info menu.*

Depending on whether a call is ongoing or not, either the Call info menu or the Ongoing call menu is shown.

To clear the call list

1. Press **(>)** until you reach the **Call info** menu.
2. Press **(v)** until the **Options** sub-menu is highlighted, press **YES**.
3. Press **(v)** until the **Clear call list** sub-menu is highlighted, press **YES**.
4. The question **Call list Clear?** appears. Press **YES** to clear the call list.

In the **Set call list** sub-menu in **Options**, you can turn the call list on or off. If you select **Off**, you are asked to clear the call list.

Automatic Re-Dialling

If the connection failed when you first called, the display shows **Retry?**. You can now re-dial the number by pressing **YES**. Your phone automatically re-dials (up to ten times):

- until the call is successfully connected. You hear a ring signal.
- until you press a key or receive a call.

Note: *Automatic re-dialling is not available for data calls.*

Making International Calls

1. Press and hold the **0** key until a **+** sign appears.

The **+** replaces the international prefix of the country from which you are calling.

2. Enter the country code, area code (without the leading zero) and phone number.
3. Press **YES**.

Making Emergency Calls



- Enter the international emergency number **112** and press **YES**.

Your Ericsson phone supports the international emergency numbers, **112**, **911** and **08**. This means that these numbers can normally be used to make an emergency call in any country, with or without a SIM card inserted, if a GSM network is within range.

Note: *Some network operators may require that a SIM card is inserted, and in some cases that the PIN has been entered as well.*

In some countries, other emergency numbers may also be promoted. Your operator may therefore save additional *local* emergency numbers on the SIM card.

To view your local emergency numbers

1. Press  to go to the **Phone book** menu.
2. Press  until **Special numbers** is highlighted, press **YES**.
3. Press  until **SOS numbers** is highlighted, press **YES**.

Showing and Hiding Your Number



Some operators offer subscriptions where your phone number can be hidden. You can choose to show or hide your number for a particular call, if your subscription supports the Calling Line Identification Restriction (CLIR) service.

+4613310960

14:49



To hide or show your phone number

1. Enter the phone number you wish to call.
2. Press .
3. Press  until **Hide my number** or **Show my numb.** is highlighted.
4. Press **YES** to make the call.

Receiving a Call

When you receive a call, the phone rings and the display shows **Answer?**

If your subscription includes the Calling Line Identification (CLI) service and the caller's network sends the number, the caller's number appears in the display. If the incoming call is a restricted number, the display shows **Withheld**. If the incoming call is an unknown number, the display shows **Unknown**.

Answering a Call

- Press **YES** to answer the call.

Rejecting a Call

- Slide the volume key on the side of the phone twice, or press **NO**.
The display shows **Busy tone**. The caller hears a busy tone if this is supported by the caller's subscription. If the **When busy** divert function is on, the call is diverted to the number you have specified. See "Diverting Calls" on page 85.

Missed Calls

If you have missed a call, the message **Missed calls: 1** appears in standby mode, where the number, in this case **1**, indicates the number of missed calls.

1. Press **YES** to display the missed calls.
2. Press **YES** to call the number.

Tip! *You can also see the missed calls list in the Call info menu. Missed calls are also saved in the call list.*

Turning Your Phone Off

- In standby mode, press and hold the **NO** key until you hear a tone.

During a Call



Earpiece Volume

During a call, you can change the earpiece volume by sliding the volume key on the side of the phone.

- Slide up to increase the volume.
- Slide down to decrease the volume.

Microphone

During a call, you can turn off the microphone.



- Press and hold  until **Muted** appears in the display.
- Press and hold  again to resume the conversation.

Tip: *Instead of pressing and holding , you can put the call on hold by pressing **YES**.*

Speakerphone

You can use your phone as a speakerphone during a call, for example when you want others to participate in a conversation or when you need to have your hands free during the call. We recommend that you use the speakerphone in a quiet environment.

To turn the speakerphone on or off

1. During a call or in standby, press .
2. Press  until **Act. Speaker** or **Deact. Speaker** is highlighted, press **YES**.

When the speakerphone is on, an icon appears.

Warning! *While the speakerphone is on, do not hold the phone close to your ear as this may cause damage to your hearing. Hold the phone about 30 - 50 cm in front of your face and speak into the microphone.*

The speakerphone is not available when you use your phone together with any handsfree equipment or when the IR port is on.



The speakerphone is always turned off when a call is ended. For safety reasons, the speakerphone is automatically turned off when the phone is approximately 10 cm from your ear or another object during a call.

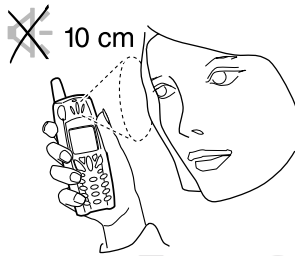



Notepad

If you want to make a note of a phone number during a call, you can use your phone display as a notepad. Use the number keys to enter the number. When you end the call, the number remains in the display. You can call the number by pressing **YES**.



Turn Off Tones

If you use the phone display as a notepad, the person you are talking to hears the tone signals when you press the keys.

To turn the tone signals on or off

1. During a call, press .
2. Press  until **Turn off tones** or **Turn on tones** is highlighted, press **YES**.

Sending Touch Tone Signals

To use touch tone services such as telephone banking or controlling an answering machine, you need to use codes. These codes are sent as touch tone signals (also known as DTMF – Dual Tone Multiple Frequency tones). If you press **0–9**,  and  during a call, these numbers and characters are sent as tone signals. You can save codes in your phone book, and during a call, you can send the codes by pressing **Find and send**. See also “Touch Tone Services” on page 40.











Ciphering

Ciphering is a built-in feature that encodes your calls and messages to provide additional privacy. An exclamation mark is shown in the display during a call to indicate that ciphering is currently *not* being provided by the network.



Key Functions

The table below explains some of the key functions. See also “Quick Keys” on page 135.





Press...	To
	make and answer calls. choose a menu, sub-menu or setting. voice dial, press and hold the key. enter the Call list, briefly press the key from standby.
	turn the phone on or off, press and hold the key. end a call. reject a call. go back one level in the menus, to leave a setting unchanged. get back to standby mode, press and hold the key.
	enter and move within the main menus, briefly press  or  .
	move (scroll) up or down through menus, lists and text.
 Clear	delete numbers and letters from the display. delete an item from a list. turn off the microphone during a call, press and hold the key. set the phone to silent, press and hold the key from standby.
 Option key	enter a menu with options. The options vary depending on what function you are currently using.
Number keys	enter the numbers 0-9. enter the international prefix (+), press and hold 0. call your voice mail, press and hold 1. enter letters.
	enter *. enter a pause (p). shift between capital and lower-case letters.
	enter #.
Volume key	increase or decrease the volume of the earpiece or handsfree loudspeaker during a call. reject an incoming call, slide the key twice. enter the Status menu, slide the key briefly.

Press...	To
Voice memo key	record voice memos, press and hold the key. enter the list of voice memos, press the key briefly.

Option Key

By means of the option key, , you can quickly reach the most common options for the function you are currently using. The option key is similar to the right mouse button of your computer.

Menus





There are seven main menus. Each menu has several sub-menus. You enter the menus by briefly pressing  or . You also use these keys to move from left to right in the main menus. To move up and down in the sub-menus, use  and . Your phone includes pop-up help texts. See “Help Texts” on page 21.

Moving through the Menu

There are two ways of moving through the menu:



- scrolling by using the keys.
- using shortcuts.

Scrolling by Using the Keys

Press...	to...
 or 	enter and move through the main menus.
 or 	move up and down through the sub-menus.
YES	select a menu, sub-menu or setting.
NO	go back one level in the menus or leave a setting unchanged. Press and hold NO to go back to standby.
	enter a quick options menu.

Tip: *When in the menus, instead of pressing the keys repeatedly to reach the sub-menu that you want, you can press and hold the arrow keys or slide and hold the volume key.*

Using Shortcuts

A quicker way to move through the menus is to use the shortcuts. First briefly press  or  to enter the menus, then enter the number of the menu or sub-menu to which you want to go. To get back to standby, press and hold **NO**. See the example on the following page.

Instructions



In the instructions in this User's Guide, we use the arrow keys to describe the functions and settings, since the shortcut numbers may vary between phones according to your subscription and network.

In this example of how to interpret the instructions, we are going to set the key sound to **Tone**.

To set the key sound

1. Scroll to **Settings**, **YES**, **Sounds & alerts**, **YES**, **Key sound**, **YES**.
2. Select **Tone** and press **YES**.

Interpret the instructions as follows:

1. From standby mode, use  or  to scroll to the **Settings** menu.

2. Press **YES** to select the menu.
You are now in the **Settings** menu.

The name of the menu that you have selected is shown at the top of the display.

3. Press **YES** to select the **Sounds & alerts** sub-menu.

4. Use  to scroll to the **Key sound** sub-menu.
Press **YES** to select the sub-menu.

5. Use  to scroll to **Tone**.



Press **YES** to select the **Tone** alternative.

You have now set the key sound to **Tone**.

To go back to standby mode, press and hold the **NO** key.

When using shortcuts, interpret the instructions as follows:

To set the key sound

1. From standby mode, press  or  to enter the menus.
2. Press **4** to select the **Settings** menu.
3. Press **1** to select the **Sounds & alerts** sub-menu.
4. Press **8** to select the **Key sound** sub-menu.
5. Select **Tone** and press **YES**.

Display Text

When you move through the menus, the display changes.

- White text on a grey background at the top indicates the menu you have selected.
- White text on a black background indicates your position in the menus. Press **YES** to enter this menu or select this setting.
- Grey text indicates a function that is temporarily unavailable, for example due to your subscription or a certain setting which is not on.
- Text marked with a tick indicates the current setting or settings selected.

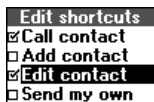
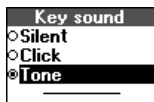
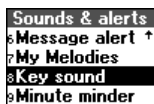

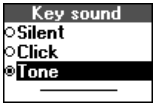

- Text marked with a filled button indicates the current setting selected.

Help Texts

Your phone includes pop-up help texts that explain the sub-menus.

To turn the help texts on or off

1. Scroll to **Settings, YES, Display, YES, Menu help, YES**.
2. Select **On** or **Off** and press **YES**.

Menu Language

Most modern SIM cards automatically set the menu language to the language of the country where you bought your SIM card, **Automatic**. If this is not the case, the pre-set language is English.

To change the menu language

1. Scroll to **Settings, YES, Language, YES, Menus, YES**.
2. Select a language and press **YES**.

To select a language that you want to use when writing text, see “Input Languages” on page 30.

Tip: *You can always select Automatic by pressing , 8888,  in standby, and English by pressing , 0000,  in standby.*

My Shortcuts

To reach your favourite functions and settings quickly and easily, you can place them in the menu **My shortcuts**. You place them there by selecting them in the list of **Edit shortcuts**.

To select your favourite settings for My shortcuts

1. Scroll to **My shortcuts, YES, Edit shortcuts, YES**.
2. Select or clear a setting from the list by scrolling to it and pressing .
3. If you select a new setting, enter the position number you want for it in this menu. Press **YES**.
4. Press **YES** to save your settings and exit the list.

When you buy your phone, the menu **My shortcuts** contains a few settings which you can delete if you wish.

Tip! *Press and hold  from standby to reach the shortcut saved in the first position in My shortcuts.*

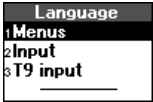

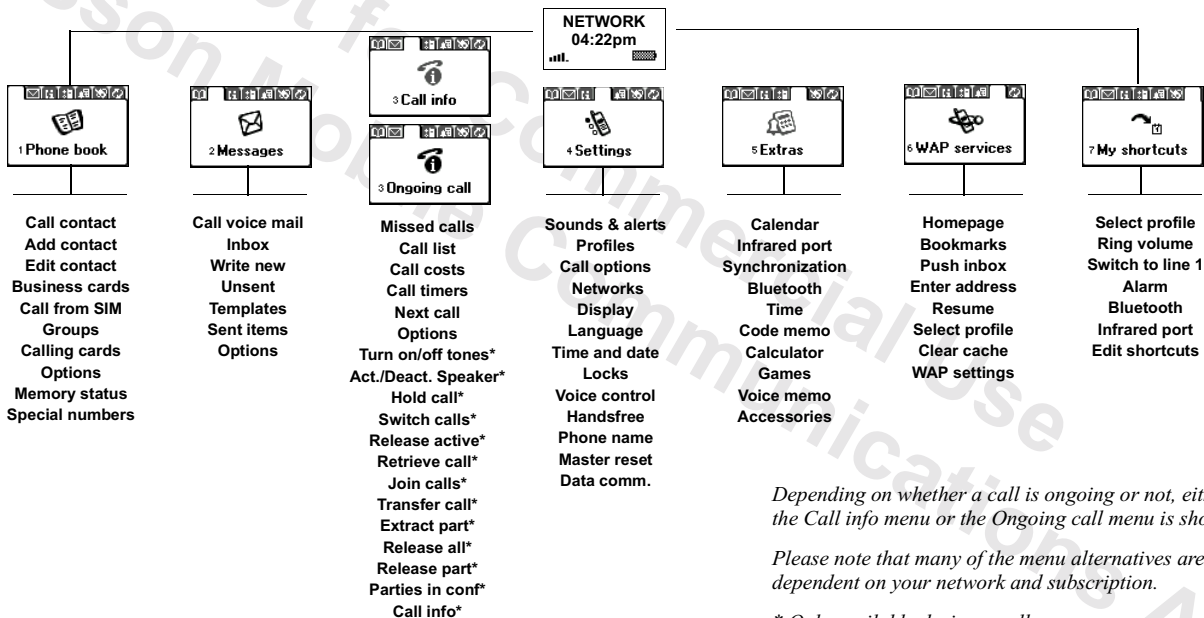

Depending on whether a call is ongoing or not, either the Call info menu or the Ongoing call menu is shown.

Please note that many of the menu alternatives are dependent on your network and subscription.

** Only available during a call.*

Personalizing Your Phone

Sounds



You can change the volume, ring signal and key sound according to your preferences. You can set a specific ring signal for a specific person so that you know who is calling by the ring signal. You can also compose your own melody and send it to another phone.

Note: *If you change a setting which is included in a profile, the profile is also changed. See “Profiles” on page 73.*

Ring Volume

You can set the volume to six levels. The first level means that only two clicks are heard when you receive a call. You can also turn the ring signal off (0). An icon then appears when in standby mode.

To set the ring volume

1. Scroll to **Settings, YES, Sounds & alerts, YES, Ring volume, YES.**
2. Use  or  to increase or decrease the volume.
3. Press **YES** to save the setting.

Tip: *Use the volume key to change the volume silently.*

Silent

You can set your phone to silent so that all signals, except the alarm and timer signals, are turned off.

To set the phone to silent

1. From standby, press .
2. Select **Turn on silent** and press **YES**.
An icon appears when in standby mode.
To cancel, repeat step 1 and press **YES** at **Turn off silent**.

Increasing Ring

You can select a ring signal, **Increasing ring**, that rises in steps from the lowest volume to the highest.

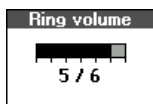

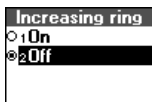

To turn the increasing ring on or off

1. Scroll to **Settings, YES, Sounds & alerts, YES, Increasing ring, YES.**
2. Select **On** or **Off** and press **YES.**

The increasing ring must be **Off** for the ring signal volume to apply.

Ring Signal Type

You can select a ring signal from a list of different sounds and melodies. See also "Composing Your Own Melodies" on page 25.

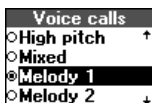

To select one of the existing ring signals

1. Scroll to **Settings, YES, Sounds & alerts, YES, Ring signals, YES, Voice calls, YES.**
2. Select the ring signal type that you want and press **YES.**

Tip: *Use the volume key to change the ring signal silently.*

The Low Pitch ring signal has been specially developed for people with hearing disabilities.

Specific Ring Signals

If you subscribe to the Two Line Service, you can set different ring signals for the two lines. **Line 1** and **Line 2** are displayed instead of **Voice calls**. If your SIM subscription supports **Data calls**, you can set different ring signals for voice and data calls.

If your subscription includes the Calling Line Identification (CLI) service, you can assign a **Personal ring signal** to up to ten callers.

To set a specific ring signal for a caller

1. Scroll to **Settings, YES, Sounds & alerts, YES, Ring signals, YES, Personal rings, YES, Add new?, YES.**
2. Enter the first letter of the contact name and press **YES.**
3. Select a contact and press **YES.**
4. Select a ring signal and press **YES.**

To delete a caller's number

1. Scroll to **Settings, YES, Sounds & alerts, YES, Ring signals, YES, Personal rings, YES.**
2. Scroll to the number you wish to delete and press **YES.**
3. Select **Delete** and press **YES.**

My Melodies	
1	My Melody 1
2	My Melody 2
3	My Melody 3
4	My Melody 4

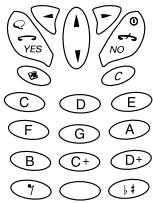

Composing Your Own Melodies

You can compose four different melodies to use as your ring signal.

To compose a melody

1. Scroll to **Settings, YES, Sounds & alerts, YES, My melodies, YES.**
2. Select **My melody 1, My melody 2, My melody 3** or **My melody 4** and press **YES.**
3. Press **(C)** to clear the display.
4. The keypad now works as a keyboard (see figure).
Use the keypad to enter notes:
 - Press and hold a key to enter a long note.
 - Press **(0)** to raise the note an octave.
 - Press **(#)** once to raise the note a semitone.
 - Press **(#)** twice to lower the note a semitone.
 - Press **(*0)** to enter a pause.
5. To listen to your melody, press **YES.**
6. Press **YES** again to save it or press **NO** to continue composing.

Tip: You can also download existing melodies from the Ericsson Mobile Internet: <http://mobileinternet.ericsson.com>. See also "Starting the WAP Browser" on page 67.

Exchanging Melodies

You can transfer your melodies to and from another similar phone or download your new melody from a computer or the Ericsson Mobile Internet. You can send and receive melodies using *Bluetooth* wireless technology, the infrared port or a text message.

To send a melody

1. Scroll to **Settings, YES, Sounds & alerts, YES, My melodies, YES.**
2. Scroll to the melody that you want to send. Press **YES.**
3. Select **Send** and press **YES.**
4. Select a transfer method and press **YES.**
5. Continue as described in "Sending and Receiving" on page 52, "Connecting IR Devices" on page 55 or "Sending Messages" on page 44.

When you receive a melody via a text message, you accept the melody by pressing **YES.** To be able to receive a melody using the infrared port or *Bluetooth* wireless technology, the recipient first needs to activate the infrared port or to make the phone discoverable.

To receive a melody

1. **New melody Play?** appears. Press **YES** if you want to hear the melody before you save it.
2. **Save melody?** appears. Press **YES**.
3. Select the position in the melody list in which you want to save the new melody, press **YES**.

Vibrating Alert

You can select to be notified of an incoming call by the buzzing of the **Vibrating alert**. You can set the phone's vibrating alert to one of the following:

- **On** (all the time)
- **On if silent** (on when the ring volume is turned off or when you have set the phone to silent)
- **Off** (all the time)

To set the Vibrating Alert

1. Scroll to **Settings, YES, Sounds & alerts, YES, Vibrating alert, YES**.
2. Select a setting and press **YES**.

Note: *When your phone is placed in a desktop charger or a car handsfree kit, the vibrating alert is automatically turned off.*

Key Sound

You can choose which sound you want the keys to make when you press them. You can choose between clicks, tones or silent.

To set the key sound

1. Scroll to **Settings, YES, Sounds & alerts, YES, Key sound, YES**.
2. Select a key sound and press **YES**.

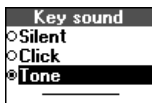

Display

You can personalize your phone display with a number of settings.

Display Light

You can set the display light to automatic, off or on. In automatic mode, the display light switches off a few seconds after you have pressed the last key.

To set the display light

1. Scroll to **Settings, YES, Display, YES, Light, YES**.
2. Select a display light setting and press **YES**.



Sleeping Display

To save battery power, you can turn on the sleeping display. The text in standby mode is reduced to one row at the bottom of the display a few minutes after you have pressed the last key.



To turn the sleeping display on or off

1. Scroll to **Settings, YES, Display, YES, Display sleep, YES.**
2. Select **On** or **Off** and press **YES.**

Contrast Setting

You can change the display's contrast.

To set the display contrast

1. Scroll to **Settings, YES, Display, YES, Contrast, YES.**
2. Use  or  to increase or decrease the contrast.
3. Press **YES** to save the setting.

Greeting Text

When you turn on your phone, a text or an image appear as a greeting in the display. You can write your own greeting instead.

To write a new greeting

1. Scroll to **Settings, YES, Display, YES, User greeting, YES.**
2. Select **Custom** and press **YES.**
3. Write your new greeting.
4. Press **YES** to confirm your setting.

To set the standard greeting

1. Scroll to **Settings, YES, Display, YES, User greeting, YES.**
2. Select **Standard** and press **YES.**

To turn the greeting off

1. Scroll to **Settings, YES, Display, YES, User greeting, YES.**
2. Select **Off** and press **YES.**

My Numbers

My numbers shows your phone number(s). If your phone number cannot be retrieved from your SIM card, you can enter it yourself.

To enter your phone number

1. Scroll to **Phone book, YES, Special numbers, YES, My numbers, YES, Voice, YES.**
2. Enter the number and press **YES.**

Tip: *You can also enter your data number and the different numbers for Line 1 and Line 2, if these are supported by your subscription.*



Text Size

You can change the size of the letters and thus the number of visible rows in the display.



To change the text size and the number of rows

1. Scroll to **Settings, YES, Display, YES, Text size, YES.**
2. Select a text size and press **YES.**

Time Settings

The time is always shown when the phone is in standby mode.

To set the time

1. Scroll to **Settings, YES, Time and date, YES, Set time, YES.**
2. Enter the time in hours and minutes (you can move from number to number by pressing  or ) and press **YES.**
You are now asked whether you want to enter more time information, such as time zone and daylight saving time. Press **YES.**
3. Select a time zone and press **YES.**
4. Select a daylight saving time and press **YES.**

To set the time format

1. Scroll to **Settings, YES, Time and date, YES, Time settings, YES, Time format, YES.**
2. Select the 24-hour or 12-hour (am/pm) clock and press **YES.**
If you select the 12-hour clock, you can alternate between am and pm by pressing .

Automatic Time Zone

Your phone is equipped with an automatic time update function. When your phone changes network, and the time sent out from the operator deviates from the time in your phone, you are asked whether you want to update the time. If you press **YES**, the time is automatically updated.

To turn the Automatic Time Zone on or off

1. Scroll to **Settings, YES, Time and date, YES, Time settings, YES, Auto time zone, YES.**
2. Select **On** or **Off** and press **YES.**

Date

When the phone is in standby mode, you can slide the volume key up or down to see today's date in the **Status** menu.

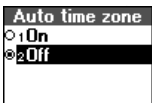
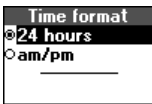

Date format
<input checked="" type="radio"/> 21-Feb-01
<input type="radio"/> 21-02-01
<input type="radio"/> 02/21/01
<input type="radio"/> 010221

To set the date format

1. Scroll to **Settings, YES, Time and date, YES, Date format, YES.**
2. Select a date format and press **YES.**

Set date
19-02-01
(DD-MM-YY)

To set the date

1. Scroll to **Settings, YES, Time and date, YES, Set date, YES.**
2. Enter the date according to the format you have chosen and then press **YES.**

Master Reset

You can reset the phone's settings to the way they were when you bought your phone.

Master reset
Phone lock code:

To reset the phone

1. Scroll to **Settings, YES, Master reset, YES, Reset settings, YES.**
2. Enter the phone lock code (**0000**) or the number you have changed it to. See "Changing the phone lock code" on page 97.
Press **YES.**

Note: *The Reset all option deletes all contacts, e-mail messages, text messages and WAP settings.*

Entering Letters

You can enter letters, for example, when you add names to the phone book, write text messages or enter WAP addresses.

Apart from the way you normally enter letters in your phone, using multitap text input, you can use **T9 Text Input** for entering text messages and e-mail, for example, if the input language you select supports this. T9 Text Input is a predictive input method and is a quicker way to write texts. See “T9® Text Input” on page 32.

Input Languages

Before you start entering letters, you need to select the input languages that you want to use when writing.

To select input languages

1. Scroll to **Settings, YES, Language, YES, Input, YES**.
2. Scroll to the language that you want to use for entering letters and press .
Repeat step 2 if you want to use another language.
3. Press **YES** to exit the menu.





When writing, you can switch to one of your selected input languages by pressing  and then selecting **Input language**. See “The List of Options” on page 33.

Multitap Text Input

When saving names in the phone book or when writing WAP addresses, you enter letters using multitap text input. You press each key as many times as needed to show the letter you want.

In the following example, we are going to write a name:

To enter letters using multitap text input

1. Scroll to **Phone book, YES, Add contact, YES**. Press **YES** again.
2. Press the appropriate key,  – ,  or , repeatedly until the character you want appears in the display.

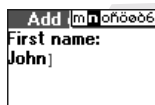

See the table of the Latin alphabet below:

Press...	to get...
1	Space - ? ! , . : ; " ' < = > () _ 1
2	A B C Ä Å Æ à Ç 2 Γ
3	D E F è É 3 Δ Φ
4	G H I i 4
5	J K L 5 Λ
6	M N O Ñ Ö Ø ò 6
7	P Q R S ß 7 Π Σ
8	T U V Ü ù 8
9	W X Y Z 9
0	+ & @ / % \$ € £ ¥ \ \$ ¿ ¡ 0 Θ Ξ Ψ Ω
#	# * ↵
C	to delete letters and numbers
* 0	to shift between capital and lower-case letters
0 - 9	press and hold to enter numbers

Example:

- To enter an 'A', press **2** once.
- To enter a 'B', quickly press **2** twice.
- To shift between capital and lower-case letters, press *** 0**, then enter the letter.

Tip: You can also use the volume key as a shortcut to certain letters:

To enter a 'B', slide the volume key up and press **2**.

To enter a 'C', slide the volume key down and press **2**.

T9® Text Input

Write new
Text:
j

Write new
Text:
in

Write new
Text:
How

Write new
Text:
How

Write new
Text:
low

You can use T9 Text Input when entering texts such as text messages. The T9 Text Input method uses a built-in dictionary to recognize the most commonly used word for every sequence of key presses. This way, you press each key only once, even if the letter you want is not the first letter on the key.

When you press the keys, different words are suggested. If the word you want is not suggested, you can edit the word (⌨). The word is then added to the dictionary so that it is suggested the next time.

In the following example, we will start writing a text message:

To enter letters using T9 Text Input

1. Scroll to **Messages, YES, Write new, YES**.
2. For example, if you want to write the word “How”, press (4), (6), (9).

The word “How” appears.

3. If the word shown is the one you want:
 - press (1) to accept and add a space.
(To accept a word without adding a space, press (➤).)

If the word shown is not the one you want:

- press (0) repeatedly to view alternative words (candidates). Accept a word and add a space by pressing (1).

If you do not find the word you want by pressing (0):

- press (⌨) to go to a list of options.
- Select **Edit word, YES**.
- Delete the entire word by pressing (C), or delete one letter at a time by pressing (➤) and then (C) repeatedly.
- Write the new word using multitap text input and press **YES**. The word is added to the dictionary. The next time you enter (4), (6), (9), the word you just added to the dictionary will appear as one of the alternative words.

4. Continue writing your message. See also “Sending Messages” on page 44.

Tip: Press (#) to enter a full stop. To enter other punctuation marks, press (#) and then (0) repeatedly. Accept by pressing (1).

Press and hold (*0) to select an input method.

The List of Options

If you press  when writing, you enter a list of options:

- **Edit word** – for T9 Text Input only
Edit the suggested word by using multitap text input.
- **Add symbol**
Symbols and punctuation marks such as ? and , are shown. Move between the symbols by using the arrow keys. Press **YES** to select a symbol.
- **Accept word** – for T9 Text Input only
Accept the suggested word and add a space.
- **Candidates** – for T9 Text Input only
A list of alternative words is shown. Scroll to a word and press **YES**.
- **Rel. caps lock/Caps lock**
Switch between capital and lower-case letters.
- **Input language**
A list of the input languages that you selected earlier is shown. If you want to change the input language for the text you are writing, scroll to a language and press **YES**.
- **Input method**
A list of input methods is shown. If you want to change the input method for the text you are writing, scroll to an input method and press **YES**.
- **Help**

Turning off the T9 Text Input

If you wish, you can turn off the T9 Text Input. This setting is valid for all input of texts – not only for the text you are currently entering.

To turn the T9 Text Input on or off

1. Scroll to **Settings**, **YES**, **Language**, **YES**, **T9 Input**, **YES**.
2. Select **On** or **Off**.

Phone Book

You can create your personal phone book by saving information about your friends and colleagues as a contact. In a contact, you can save details such as name, title, phone numbers and e-mail address – all in one place.

Saving Contacts

For each contact, you can fill in the following information: first name, last name, company, title, home phone number, work phone number, mobile phone number, other phone number and e-mail address. The contacts are saved in the phone. To save the numbers to the SIM card, see “To copy contacts to the SIM card” on page 37.

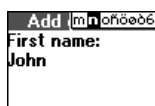
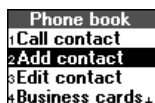

To add a new contact

1. Scroll to **Phone book**, **YES**, **Add contact**, **YES**.
2. Press **YES** and enter a first name. Press **YES** and enter a last name, and so on.
When you enter phone numbers, you can press  to retrieve a phone number from the phone book, the SIM card or from a list of unsaved numbers.
3. When you have filled in the information you want, scroll to **Save and exit** and press **YES**.
If voice dialling is on, you are asked if you want to save a voice command for the contact.

Note: *Each phone number saved occupies one position in the memory. You can save around 500 positions in the phone. Please contact your network operator to find out how many numbers you can save on the SIM card.*

Ask to Save

If you make or receive a call from a number that is not saved in your phone book, you are asked if you want to save the number. If you do not want to be asked, you can turn the Ask to save function off.

To turn the Ask to save function on or off

1. Scroll to **Phone book**, **YES**, **Options**, **YES**, **Ask to save**, **YES**.
2. Select **On** or **Off** and press **YES**.

Calling a Contact

To call a phone number saved in a contact, use the **Call contact** function. You can find the contact by searching for either first or last name, depending on which sort order you have set.



To select a sort order

1. Scroll to **Phone book, YES, Options, YES, Sort order, YES**.
2. Select a sort order and press **YES**.

To call a contact

1. Scroll to **Phone book, YES, Call contact, YES**.
2. Enter the first letter of the contact name and press **YES**.
3. If the default phone number of the contact is the number you want to call, press and hold **YES**.

If you want to call another phone number, press **YES** to go to the contact.

Press  or  to go to the phone number you want to call.

Press **YES** to make the call.

Tip: *A quicker way to enter the Call contact menu is to press and hold  from standby.*

Shortcuts to Contacts

When in standby, you can find a contact by:



- pressing and holding one of the keys **2-9** to find a contact beginning with a specific letter.

For example, pressing and holding **2** takes you to the first contact beginning with the letter A (or closest following).

Shortcuts to Phone Numbers

When in standby, you can find a phone number on the SIM card by:

- entering its position number followed by .

Once you are in the list of contacts you can use  or  to scroll through the list, or a letter to go to a certain name.

To see the position of the phone numbers that you have saved, go to **Phone book, YES, Options, YES, Position list, YES**.

Speed Dialling

You can call the phone numbers that are saved in positions 1–9 on the SIM card.

- From standby, enter the position number and press **YES**.





See also “To change position numbers” on page 37. To copy contacts in your phone to your SIM card, see “To copy contacts to the SIM card” on page 37.

Editing the Phone Book

You can edit a contact in the phone book with the **Edit contact** function.

Tip: *When you have selected a contact in your phone book, you can edit the contact by pressing  and then selecting **Edit**.*

To edit a contact

1. Scroll to **Phone book, YES, Edit contact, YES**.
2. Enter the first letter of the contact you want to edit. Press **YES**.
If the contact shown is not the one you want, press  or  until you find the correct contact.
3. Press **YES**.
Select **Edit name** or **Edit numbers** and press **YES**.
You can edit the voice command for the contact name by selecting **Edit voice**. You can edit the position for a phone number by selecting **Edit positions**.
4. Press  or  to go to the details that you want to edit.
5. When editing phone numbers, you can press  to retrieve a phone number from the phone book, the SIM card or from a list of unsaved numbers.
6. When you have made your changes, press **YES**. Scroll to **Save and exit** at the bottom of the list and press **YES**.

If you scroll to a certain contact in your phone book and then press and hold **YES**, the default phone number of the contact is dialed. You can select another default phone number for a contact, if you wish.

To set a default number

1. Scroll to **Phone book, YES, Edit contact, YES**.
2. Enter the first letter of the contact you want to edit. Press **YES**.
3. Press **YES** to select a contact.
4. Select **Default number** and press **YES**.
5. Select the number you want as the default phone number. Press **YES**.



To delete a contact

1. Scroll to **Phone book, YES, Edit contact, YES**.
2. Enter the first letter of the contact you want to delete.
3. Press **C** to delete the contact.
4. Press **YES** to confirm.

To delete all contacts select **Phone book, YES, Options, YES, Delete all, YES**.

Tip: *Your contacts can be synchronized with a program running on a PC or a PDA. See "Synchronization" on page 61.*

You can organize your phone book so that the phone numbers you use most frequently are easily available. You can, for example, have certain numbers saved in positions 1-9 to be able to speed dial them.

To change position numbers

1. Scroll to **Phone book, YES, Options, YES, Position list, YES**.
2. Scroll to the phone number you want to move, press **YES**.
3. Scroll to the position to which you want to move the phone number and press **yes**. The phone numbers switch positions.
4. When you have finished, press **NO**.

A question appears. Press **YES** if you want to copy the changes to the SIM card.

Copy to and from the SIM Card

Your contacts are saved in the phone. If you want to speed dial or if you want to use your contacts in another phone, you first need to copy the contacts to the SIM card. The contacts on the SIM card are then replaced by the contacts in the phone.

To copy contacts to the SIM card

- Scroll to **Phone book, YES, Options, YES, Copy to SIM, YES**.

If you insert a SIM card with saved contacts into your phone, you can call the contacts on the SIM card by selecting **Call from SIM**. To be able to edit the contacts saved on the SIM card, you first have to copy the SIM card contacts to the phone by selecting **Copy from SIM**.

To copy contacts to the phone

- Scroll to **Phone book, YES, Options, YES, Copy from SIM, YES**.

To call a contact saved on the SIM card

1. Scroll to **Phone book, YES, Call from SIM, YES**.
2. Enter the first letter of the contact name and press **YES**.

3. Press **YES** to call the contact.

Tip: *When one of the numbers in Call from SIM is highlighted, you can copy the number to the phone by pressing  and then selecting Copy to phone.*

Business Cards

You can add your own business card as a contact in the phone book. You can then exchange business cards with your colleagues via your phone.

To add or edit your business card

1. Scroll to **Phone book, YES, Business cards, YES, My own, YES**.
2. Select **Add my own** and press **YES**.
3. Proceed as in “To add a new contact” on page 34.

If you have already entered your own details as a contact, you may want to use this contact as your business card.

To use a contact as your business card

1. Scroll to **Phone book, YES, Business cards, YES, My own, YES**.
2. Select **Use contact** and press **YES**.
3. Enter the first letter of the contact you want to use as your business card. Press **YES**.
4. If the highlighted contact is not the one you want, scroll through the list until you find the correct contact. Press **YES**.

To delete your business card

1. Scroll to **Phone book, YES, Business cards, YES, My own, YES**.
2. Select **Delete my own** and press **YES**.
The entry is still available in the phone book as an ordinary contact.

Exchanging Business Cards

You can exchange contacts and business cards between your phone and another similar phone, a PDA or a PC using *Bluetooth* wireless technology, the infrared port or a text message.

To send your own business card

1. Scroll to **Phone book, YES, Business cards, YES, Send my own, YES**.
2. Select a transfer method and press **YES**.
3. Continue as described in “Sending Messages” on page 44, “Sending and Receiving” on page 52 or “Connecting IR Devices” on page 55.

When you receive a business card via a text message, you accept the card by pressing **YES**. To be able to receive a business card using the infrared port or *Bluetooth* wireless technology, the recipient first needs to select the **Receive** menu in order to activate the infrared port or to make the phone discoverable.

To receive a business card

1. Scroll to **Phone book, YES, Business cards, YES, Receive, YES**.
2. Select a transfer method and press **YES**.
3. When you receive the business card, press **YES** to save the card in your phone book.
4. **Add to phone book?** appears. Press **YES**.
5. **Reply with own business card** appears. Press **YES** if you want to reply.

To send a contact

1. Scroll to **Phone book, YES, Business cards, YES, Send contact, YES**.
2. Enter the first letter of the contact and press **YES**.
3. Select the contact you want to send, **YES**.
4. Select a transfer method and press **YES**.
5. Continue as described in “Sending Messages” on page 44, “Sending and Receiving” on page 52 or “Connecting IR Devices” on page 55.

To send the complete phone book, select **Send phone book**. You can send the complete phone book using the infrared port or *Bluetooth* wireless technology.

Tip: *You can send business cards and contacts to specific Bluetooth printers and have them printed out.*

Groups

You can create groups of contacts. In this way you can send a text message to several recipients at the same time. See “Sending Messages” on page 44.

To create a new group

1. Scroll to **Phone book, YES, Groups, YES**.
2. Select **Add group** and press **YES**.
3. Enter a name for the group and press **YES**.
4. Scroll to **Add member, YES**.

5. Enter the first letter of the contact you want to add. Press **YES**. If the contact shown is not the one you want, press or until you find the correct contact. Press **YES**.
6. Select a number and press **YES**.
7. To add the next member, scroll back to **Add member** and press **YES**.

To add a new member to an existing group

1. Scroll to **Phone book, YES, Groups, YES**.
2. Select the group that you want to edit and press **YES**.
3. Scroll to **Edit, YES, Add member, YES**. Continue the same way as when you add a new member to a new group (see above).

To edit the name of a group

1. Scroll to **Phone book, YES, Groups, YES**.
2. Select the group name that you want to edit and press **YES**.
3. Select **Edit group name** and press **YES**.
4. Enter the new name of the group and press **YES**.

To delete a member from a group

1. Scroll to **Phone book, YES, Groups, YES**.
2. Select the group that you want to edit and press **YES**.
3. Select **Edit** and press **YES**.
4. Scroll to the member that you want to delete and press .
5. Press **YES** to confirm your choice.

To delete a group

1. Scroll to **Phone book, YES, Groups, YES**.
2. Select the group that you want to delete and press **YES**.
3. Select **Delete group** and press **YES**.
4. Press **YES** to confirm your choice.

Touch Tone Services

You can save a phone number together with tone signals and codes in your phone book. When you call this entry, the phone number and all the tone signal codes are then dialled automatically. This could be useful, for example, when accessing an answering machine or when using telephone banking services.

Note: *Saving personal codes in the phone book involves a risk if your phone is stolen. It is safer to save personal codes in the Code memo. See "Code Memo" on page 101.*

To save a phone number together with tone signals and codes

1. Scroll to **Phone book**, **YES**, **Add contact**, **YES**.
2. Press **YES** and enter the name that you want to associate with the phone number and code. Press **YES**.
3. Scroll to **Other** and press **YES**.
4. Enter the phone number. Press and hold ***0** until the pause character **p** appears in the display. Enter the code, if needed, enter another pause, another code and so on. Press **YES**.
5. Scroll to **Save and Exit** and press **YES**.

Checking the Memory

With the **Memory status** function in your phone book, you can check how many positions you have left in your memory.

To check the status of your phone book memory

1. Scroll to **Phone book**, **YES**, **Memory status**, **YES**.
2. Use **▲** or **▼** to scroll through the list.

Text Messages

You can send and receive text messages with the Short Message Service (SMS) using your mobile phone.

Before Sending Messages

Before you send a text message for the first time, make sure you have made the settings below.

Service Centre

If you want to send or reply to a text message, your network operator's service centre number must be set. Most SIM cards already contain the service centre number. In some cases you may have to activate it. You must obtain the number from your network operator.

To activate a service centre number on the SIM card

1. Scroll to **Messages, YES, Options, YES, Service centres, YES.**
2. Scroll to the number you want and press **YES.**
3. Select **Activate** and press **YES.**

If no number is found in the list, you have to enter the number yourself.

To enter the phone number of your service centre

1. Scroll to **Messages, YES, Options, YES, Service centres, YES, Add new?, YES.**
2. Enter the number, including the international sign (+) and country code and press **YES.**

To send a text message as an e-mail message, you first need to enter your e-mail gateway number. For details, please contact your network operator. See also "Message Options" on page 43.

To enter an e-mail gateway number

1. Scroll to **Messages, YES, Options, YES, E-mail gateways, YES, Add new?, YES.**
2. Enter the e-mail gateway number and press **YES.**

Using GPRS

You can send a text message using GPRS as the access type. For more details, please check with your network operator.

To select GPRS as the access type

1. Make sure you have created a **data account** and selected **Automatic** as the preferred service. See “Data Account Settings” on page 62 and “GPRS and GSM Data Settings” on page 64.
2. Scroll to **Settings, YES, Data comm., YES, SMS access, YES.**
3. Select **GPRS preferred** and press **YES.**

Message Options

You can create the settings below as default for all your messages, or you can turn on the option **Set on send**, which means that you choose the settings each time you send a message.

- **Message type**

You can select how you want your text message to be interpreted by the recipient, for example, as a text message, or as a fax or e-mail message.

- **Validity period**

If your message cannot be delivered because the recipient has turned off the phone, your service centre can save the message to send it later, within a certain time period.

- **Reply request**

If you want the recipient of your message to reply, you can turn on the **Reply request** option. You are usually charged for the reply. Please contact your network operator for details. When you send a message, you are asked whether you want the recipient to reply or not.

- **Status request**

With this option on, you can view the status of a sent message. For more information, see “Status Report” on page 45.

To set a default value for the options above

1. Scroll to **Messages, YES, Options, YES.**
2. Select the option you want and press **YES.**
3. Select **Set default** and press **YES.**
4. Select your default value from the list and press **YES.**

To turn Set on send on or off

1. Scroll to **Messages, YES, Options, YES.**
2. Select the option you want and press **YES.**
3. Select **Set on send** and press **YES.**
4. Select **On** or **Off** and press **YES.**

Sending Messages

You use the keypad to enter the message you want to send. For information on how to enter text, see “Entering Letters” on page 30. You can send your message to one person or to a pre-defined group, specified and saved in the phone book. For more information on how to create groups, see “Groups” on page 39. When you send text messages to a group, you are charged for each member included in the group.

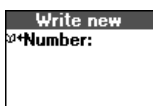

To send a message

1. Scroll to **Messages**, **YES**, **Write new**, **YES**.
2. Enter your message and press **YES**.
3. Enter the recipient's number or press  to retrieve the number from the phone book or the call list.
4. Press **YES** to send the message.

Sending msg appears in the display followed by **Message has been sent**.

Saving the Message for Later Use

- Press **NO** after you have entered your message. The message is saved in the **Unsent** menu.

To send a message later

1. Scroll to **Messages**, **YES**, **Unsent**, **YES**.
2. Select the message you want to send and press **YES**.
3. Press **YES** again.
4. Select **Send** and press **YES**.
You may now edit your message.
5. Press **YES** and send the message as described above.

Long messages

A short text message can contain up to 160 characters. You can send a longer message, but it is automatically divided into several shorter messages (up to six messages) and you are charged for each message.

To turn long messages on or off

1. Scroll to **Messages**, **YES**, **Options**, **YES**, **Long message**, **YES**.
2. Select **On** or **Off** and press **YES**.

To send a long message

1. Scroll to **Messages, YES, Write new, YES**.
2. Enter your message and press **YES**.
The display shows how many parts the message is divided into, **SMS 2, SMS 3** and so on.
3. Enter the recipient's number or press  to retrieve the number from the phone book or the call list.
4. Press **YES** to send the message.

Note: *If the recipient's phone does not support long messages, the messages are received one at a time.*

Templates

If you have one or more standard messages that you often use, you can save these as templates in your phone. You can save up to ten templates consisting of up to 30 characters each.

To create a template

1. Scroll to **Messages, YES, Templates, YES, Add new?, YES**.
2. Enter the message and press **YES**.
3. To send the message now, press **YES** when **Send message now?** appears in the display, and proceed as described in "Sending Messages" on page 44. The message is saved in the list of templates.
4. If you do not want to send the message now, press **NO**.
The message is saved as a template for later use.

If you want to use a template as a message, scroll to **Messages, YES, Templates, YES**, select the template you want from the list and then select **Write new**.

To delete a template, scroll to **Messages, YES, Templates, YES**. Select the template you want to delete and press , **YES**.

Status Report

You can request a status report for a sent text message, providing your network supports the status report service. In the status report you can see if the message has been delivered or not.

To request a status report for a sent message

1. Scroll to **Messages, YES, Sent items, YES**.
2. Scroll to the message you want a status report for and press **YES**.
3. Press **YES** again.
4. Select **Status request** and press **YES**.





To check the status of a sent message

- Scroll to **Messages, YES, Sent items, YES, View status, YES.**

Receiving Messages



When you receive a message, the phone beeps (see “Message Signal” on page 48), the indicator light on the top of the phone rapidly flashes green and the message **New message Read now?** appears in the display.

To read the message at once

1. Press **YES** when you see the question **New message Read now?**. If you have received several messages, and you press **YES** at the question above, you enter the **Inbox**. Select the message that you want to read and press **YES**.
2. Scroll through the message by using the  and  keys. An arrow in the bottom right-hand corner of the display indicates that there is more text in the message. All parts of a long message may not be received at the same time. ... indicates that part of the message has yet to be received.

Note: *If the sender of the message wants you to reply, the display shows ‘Reply requested Reply?’ when you press **YES** at the end of the message. Press **YES** again to reply. If you do not want to reply, press **NO**.*

To read a message later

- Press **NO** when you see the question **New message Read now?**. The message is saved in the phone and an envelope icon appears at the top of the display. If you want to read the message, you can retrieve it from the **Inbox** menu.
 -  means an unread message.
 -  means that the message is saved on the SIM card.

List of Options

If you select a message in the **Inbox** by pressing **YES** and then press , you can see a list of options: **Delete, Reply, Forward, Save, Call, Mail to, Save [number], Send to printer, Read next.**

Tip: *You can also reach a list of options in the **Unsent or Sent items** menus, by pressing  after selecting a message.*

To delete a message

- There are two ways to delete a message:
 - Select **Delete** in the list of options and press **YES**.
 - In the **Inbox** menu, scroll to a message and press , **YES**.

To reply to a message

1. Select **Reply** in the list of options and press **YES**.
2. Select the way you want to reply to the message:
 - enter a new message
 - include the message you want to reply to and enter a reply
 - use a template and enter a replyand press **YES**.
3. Enter your reply and press **YES** to send the message.

To forward a message

1. Select **Forward** in the list of options, press **YES**.
2. You can now edit the message. Press **YES**.
3. Enter the recipient's phone number, or press  to retrieve the number from the phone book or the call list. Press **YES** to send.

To save a received message

- Select **Save** in the list of options and press **YES**.
The message is saved on the SIM card. Messages that are saved on the SIM card remain there until you delete them.

To call the sender of a message

- Select **Call** in the list of options and press **YES**.

Tip: *To call a phone number found in a message, press **YES** when the number is **highlighted** and then press **YES** again.*

To save a phone number found in a message

1. When the number is highlighted, press **YES**.
2. Select **Save** [number] and press **YES**. You can find the number in a list of unsaved numbers. To add the number to the phone book, see "To add a new contact" on page 34.

To send a message to an e-mail address found in a message

1. Make sure you have set the e-mail gateway number, see "To enter an e-mail gateway number" on page 42.
2. Select **Mail to** in the list of options and press **YES**.
3. Enter a message and press **YES**.
4. Press **YES** again to send the message.

You can send a message to an Ericsson-approved *Bluetooth* printer and have the message printed out.

To send a message to a printer

1. Select **Send to printer** in the list of options, press **YES**.
2. Select **Via Bluetooth**, **YES**.
3. Select the relevant printer in the list of devices, **YES**.

Message Signal

You can choose the signal you want to hear when you receive a message. You can choose between clicks, tones or silent.

To set the message signal

1. Scroll to **Messages**, **YES**, **Options**, **YES**, **Message alert**, **YES**.
2. Select a signal and press **YES**.

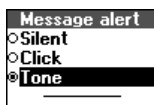

Area Information

The ordinary Short Message Service is a personal service that carries your private messages. Area Information is another type of text message, for example a local traffic report or the phone number of a local taxi company, that is sent to all subscribers in a certain network area. Please contact your network operator for further details.

To turn area information on or off

1. Scroll to **Messages**, **YES**, **Options**, **YES**, **Area info**, **YES**, **Reception**, **YES**.
2. Select **On** or **Off** and press **YES**.

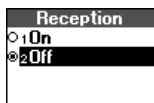

Area Information Message List

You can decide which types of area information messages you wish to receive. The number of area information codes that can be saved depends on your SIM card.

To enter an area information code

1. Scroll to **Messages**, **YES**, **Options**, **YES**, **Area info**, **YES**, **Edit list**, **YES**, **Add new?**, **YES**.
2. Enter the new code and press **YES**.



To delete an area information code

- If you want to delete a code, scroll to the code and press **C**.

Cell Information

The cell information channel is used by some network operators for sending messages to their subscribers within a certain network area.

To turn cell information on or off

1. Scroll to **Messages**, **YES**, **Options**, **YES**, **Cell information**, **YES**.
2. Select **On** or **Off** and press **YES**.

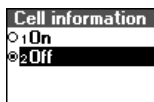

Bluetooth™ Wireless Technology

Your phone has built-in *Bluetooth* wireless technology. Short-range radio links operate in a globally available frequency band and make it possible for you to connect your phone wirelessly to different *Bluetooth* devices such as a headset, PC, PDA or printer. You can have a conversation via a cordless *Bluetooth* headset or browse the Internet on a PC wherever you are, wirelessly connected via a mobile phone. You can exchange information such as your business card, contacts, calendar appointments and tasks, ring melodies and game commands. You can automatically synchronize information in your phone and your PC. You may connect to several *Bluetooth* devices, but only one at a time.



Note: *For best performance, we recommend that your phone and the Bluetooth device you are communicating with are within a range of 10 metres. In some situations, avoiding solid objects in between your phone and the other Bluetooth device may improve the connection.*

Before You Start

Before you start communicating with a *Bluetooth* device, an accessory such as a cordless *Bluetooth* headset or a PC, you need to:

- pair your phone with the device – you do this by adding the device to a list of paired devices in your phone.
- set your computer for *Bluetooth* communication – for communication between your phone and a PC.

Note: *To browse the Internet via Bluetooth wireless technology on a PC, you need to install the Bluetooth installation software which you can find on the Ericsson CD that comes with your mobile phone.*

To exchange melodies, business cards, calendar entries or game commands using *Bluetooth* wireless technology, you do *not* need to pair your phone with the other device. You only need to make sure that the devices are within range of each other, and that the operation mode is set to Automatic or On. See “Operation Modes” on page 51.

Pairing

Pairing is the process of associating *Bluetooth* devices with each other so that they connect as soon as they get within range of each other. Your phone can be paired with up to ten *Bluetooth* devices. You can initiate the pairing between two *Bluetooth* devices from your own phone or you can accept a request for pairing from the other device. After having paired your phone with the other *Bluetooth* device, the operation mode is automatically set to On. See “Operation Modes” on page 51.

To initiate pairing with a device

1. Scroll to **Extras, YES, Bluetooth, YES, Paired devices, YES, Add device?, YES, Phone initiates, YES**.
2. A list of device types that can be paired with your phone is shown. Scroll to a device type and press **YES**. If you are not sure about what type of device you want to pair with your phone, you can choose **All**.
3. The phone starts to search for *Bluetooth* devices. When the search is finished, the display shows available devices of the type you selected. Select the device that you want to pair with your phone by pressing **YES**.
4. Enter a passkey (up to 16 digits) for both your phone and for the other device. (If a passkey does not come with the *Bluetooth* device when you buy it, you need to create one yourself.)
5. When the pairing has been completed, you may edit the name tag for the device and press **YES**.

Tip: *Grey icons are Bluetooth devices that have not yet been paired with your phone. See “Icons” on page 131 for information about icons that may appear in the phone display.*

To accept pairing with a device

1. Scroll to **Extras, YES, Bluetooth, YES, Paired devices, YES, Add device?, YES, Phone accepts, YES**.
The phone waits for the other device. This may take a while.
2. A question appears. Press **YES** to confirm the pairing.
3. Enter an identical passkey on the phone and on the other device.
4. When the pairing has been completed, you may edit the name tag for the device and press **YES**.

You can edit the list of paired devices, for example by editing the name tag of a device, deleting a device from the list or by editing the order of the devices in the list.

To edit the name tag of a device

1. Scroll to **Extras, YES, Bluetooth, YES, Paired devices, YES**.
2. A list of paired devices is shown. Scroll to the device you want to edit and press **YES**.
3. Scroll to **Edit** and press **YES**.
4. Edit the name tag and press **YES**.

To delete a device from the list

1. Scroll to **Extras, YES, Bluetooth, YES, Paired devices, YES**.
2. Scroll to the device and press **(c)**. **Delete?** appears. Press **YES**.

To edit the order of the devices in the list

1. Scroll to **Extras, YES, Bluetooth, YES, Paired devices, YES**.
2. Scroll to the device whose position you want to change and press **YES**.
3. Enter the position number (2 - 10) you want for the device.
(Position 1 is always for the headset.)

Phone Name

You can choose a name for your phone. This name is shown in other devices when your phone is discovered.

To enter a name for your phone

1. Scroll to **Settings, YES, Phone name, YES, Edit, YES**.
2. Enter a name and press **YES**.
The name is also used for the infrared port.

Operation Modes

There are four different operation modes, depending on what you want the phone to do:

- **Off** – the phone cannot send or receive any information.
- **Automatic** – The *Bluetooth* function is activated automatically when you start sending information such as a business card or when you answer an incoming call by pressing the *Bluetooth* headset button.
- **On** – the *Bluetooth* function is activated all the time (until you change the mode). The phone can send and receive information to and from a paired *Bluetooth* device.
- **Discoverable** – the phone can receive information from any *Bluetooth* device and can accept pairing.

Note: *In countries where the use of **Bluetooth** wireless technology is not allowed, you must ensure that the **Bluetooth** function is set to Off.*

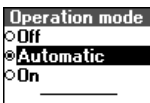

To change the operation mode

1. Scroll to **Extras, YES, Bluetooth, YES, Operation mode, YES**.
2. Select **Off, Automatic** or **On** and press **YES**.

In order to be detected by *Bluetooth* devices searching for other *Bluetooth* devices in the vicinity, you must make your phone **discoverable**.

To make the phone discoverable

- Scroll to **Extras, YES, Bluetooth, YES, Discoverable, YES**.
Your phone is discoverable for a few minutes. It then returns to the operation mode that it was in before.

Searching for Devices

You can choose first to search for *Bluetooth* devices and then, for example, to pair the device with your phone, or to exchange business cards.

To discover devices

1. Scroll to **Extras, YES, Bluetooth, YES, Discover devices, YES**.
A list of discovered devices appears.
2. You can now choose to add the device to the list of paired devices as long as the list is not full.

Note: *The devices are not shown in the list of devices unless they are discoverable.*

Sending and Receiving

To send an item such as a business card, a calendar appointment or a melody using *Bluetooth* wireless technology, you need to make sure that the devices are within range of each other.

The procedure of sending items via *Bluetooth* wireless technology differs depending on the item you want to send. See “Exchanging Melodies” on page 25, “Exchanging Business Cards” on page 38 and “Exchanging Calendar Entries” on page 59.

To send an item

- After you select **Bluetooth** as the transfer method, the phone searches for devices. A list of devices appears. Select the device you want to send the item to and press **YES**.

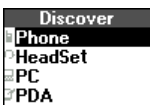

There are certain items in your phone that you can send to specific *Bluetooth* printers and have printed out. This can be useful if, for example, you want to print an overview of all the meetings that you have scheduled in your phone. Select the relevant printer in the list of devices.

These are items you can send to printers using *Bluetooth* wireless technology:

- Monthly, weekly and daily overviews
- Appointments and tasks
- Contacts
- Business cards
- Text messages

To receive an item

- To be able to receive an item, do one of the following:
 - scroll to the **Receive** menu and press **YES**.
For example, to receive a calendar appointment, scroll to **Extras, YES, Calendar, YES, Receive, YES**.
 - set the phone to **Discoverable** mode.

Infrared Port

Your phone is equipped with a port using infrared (IR) as a communications link. With IR you can connect your phone to another similar phone, a PDA or a PC. You can send and receive, for example, calendar appointments and tasks, business cards, melodies and game commands.

Before you start communicating with another IR device, you need to ensure that:

- the IR port is on.
- the IR devices are placed so that the IR ports are facing each other.
- the software for infrared communication is installed.

You can find the software installation on the enclosed CD.

Note: *To be able to use the browsing services, you have to have PC programs for the respective services.*

Activating the IR Port

The IR port has three settings:

- **On.** The phone keeps searching for other IR devices until the port is turned off. When the IR port is set to on, an icon appears in the display.
- **Off.** The port is not active.
- **10 minutes.** The port is automatically turned off 10 minutes after the last data transmission.

To set the IR port

1. Scroll to **Extras, YES, Infrared port, YES.**
2. Select **On, Off** or **10 minutes** and press **YES.**



Connecting IR Devices

Place your phone and the other device so that the IR ports are facing each other. Make sure that the IR function is activated on both devices.

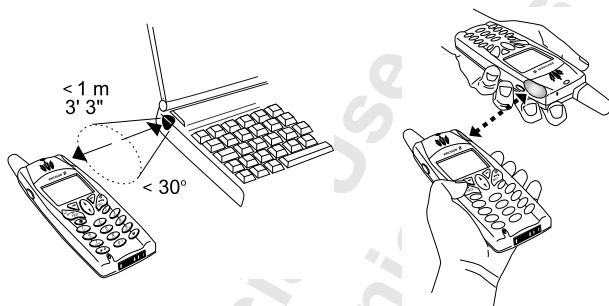

You can move the devices out of line for a short while (approximately 15-20 seconds) without interrupting the connection.

Strong sunlight can interfere with infrared light.

Phone Name

You can choose a name for your phone. This name is shown in other devices when they are connected to your phone.

To enter a name for your phone

1. Scroll to **Settings, YES, Phone Name, YES, Edit, YES**.
2. Enter a name and press **YES**.

The name is also used for *Bluetooth* wireless technology.

Calendar

You can use the calendar to keep track of important meetings that you need to attend, phone calls that you need to make or tasks that you need to do.

Appointments and Tasks

You can save up to 200 appointments and tasks in your calendar, depending on the size of each item. You can choose to add a new appointment or task, or use an old appointment or task as a template by copying and editing it.

- **Appointments:** meetings, vacation, phone call, etc.
- **Tasks:** make a phone call, send a message, pay bills etc.

You can fill in different types of information about the appointments or tasks.

To add a new appointment

1. Scroll to **Extras, YES, Calendar, YES, Add appointm., YES.**
2. Select the type of appointment and press **YES.**
3. Press **YES** and enter a subject.

If the appointment is a meeting, you can press  to retrieve a contact from the phone book.

4. Scroll to **Location**, press **YES**, enter a location, and so on.
5. Scroll to **Continue?** and press **YES.**
6. Press **YES** and enter a start date or press  and select a date. Scroll to **Time**, press **YES**, enter a start time, and so on.
7. Scroll to **Continue?** and press **YES.**
8. Select the reminder interval you want, for example **5 min before**, and press **YES.**

If you select **Oth. reminder**, enter a reminder date and press **YES.** Enter a reminder time and press **YES.**

9. A list of options appears.

If the appointment is recurrent:

- Select **Recurrent app.** and press **YES.**
- Select the recurrence you want and press **YES.**

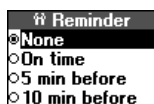

- If you want to set an end date, select **Set end date** and press **YES**. Enter a date and press **YES**.

If you want to change the class for your appointment:

- Select **Class** and press **YES**.
- Select the class you want and press **YES**.

If you want to set the time zone for a meeting:

- Select **Time zone** and press **YES**.
- Select a time zone and press **YES**. Your meeting time will be adjusted automatically according to the time zone you are in.

10. Confirm with **Save and close, YES**.

To add a new task

1. Scroll to **Extras, YES, Calendar, YES, Add task, YES**.

2. Select a task and press **YES**.

If you select phone call, enter a number and press **YES**.

If you select message, select a type of message and press **YES**.

If you select miscellaneous, select a type and press **YES**.

3. Press **YES** and enter a subject. Scroll to **Descr.**, press **YES** and enter a description.

4. Scroll to **Continue?** and press **YES**.

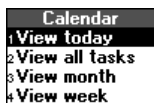
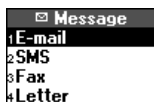

5. If you want to set a reminder, scroll to **Set reminder** and press **YES**. Enter a reminder date and press **YES**.

6. A list of options appears. Confirm with **Save and close, YES**.



Viewing Your Calendar

To view your calendar content, scroll to **Extras, YES, Calendar, YES** and then select one of the following:



- **View today.** This shows see all the appointments for the current day and the tasks that have not been completed. An icon appears next to those appointments that cover the whole day. To see options for your appointments or tasks, press .
- **View all tasks.** This shows all your entered tasks. Scroll to the task you want to view and press **YES**. To see options for your tasks, press .
- **View month.** This shows a whole month, with the current day in a square. Move within and among the weeks by using the arrow keys. Press **YES** to enter a certain day. Days on which you have appointments are marked in bold. When in month view, you can press  to select another year, month or week.
- **View week.** This shows a whole week. All your appointments and tasks are shown as grey boxes. You enter a certain day by pressing

YES when that day is highlighted. When in week view, you can press  to select another week.



Editing and Deleting

You may wish to edit an appointment or a task, for example, by changing the date or location.

To edit or delete an appointment

1. In the calendar, scroll to the day of the appointment you want to edit and press **YES**.
If you want to delete the appointment, press . **Delete?** appears, press **YES**.
2. To edit, press .
3. Select **Edit** and press **YES**.
4. Proceed as described in “To add a new appointment” on page 56.
5. When you have finished, scroll to **Save and close** and press **YES**.

To edit or delete a task

1. Scroll to **Extras, YES, Calendar, YES, View all tasks, YES**.
2. Select a task.
If you want to delete the task, press . **Delete?** appears, press **YES**.
3. To edit, press .
4. Select **Edit** and press **YES**.
5. Proceed as described in “To add a new task” on page 57.
6. When you have finished, scroll to **Save and close** and press **YES**.

The List of Options

When you have selected an appointment or a task in one of the calendar views, you can press  to view a list of options. You may now choose one of the following options:

- **Edit**. Enter the correct date, time and so on and press **YES** after each entry. When you have finished editing the appointment or task, scroll to **Save and close** and press **YES**.
- **Delete**. Press **YES** to delete an appointment or a task.
- **Send**. See “Exchanging Calendar Entries” on page 59.
- **Reschedule**. You can re-schedule an appointment. Select a week in the monthly view and press **YES**. Select a day in the weekly view and press **YES** to re-schedule the appointment to the selected day. Edit and press **YES**.
- **Copy**. You can use an old appointment or task as a template by copying and editing it. Enter a category, description and so on, and

Options	
1	Status
2	Class view
3	Delete all
4	Reminders

confirm each entry by pressing **YES**.

- **Call.** Select a task or an appointment that contains a phone number in the subject, and press **YES** to make the phone call.

Calendar Settings

To view your calendar options, scroll to **Extras, YES, Calendar, YES, Options, YES**, and then select one of the following:

- **Status.** Use this to check when you last synchronized your calendar, how much space is left for new appointments and tasks.
- **Class view.** You can choose whether to see only the private calendar entries, only the public ones or both.
- **Reminders.** Turn on this function if you want your phone to remind you even though the phone is turned off.
- **Profile switch.** If you set the profile switch reminder function to **On**, the question **Switch profile?** appears when a meeting is about to start. Press **YES** to view the list of profiles and select a profile. After the meeting, you are asked to switch profile again.
- **Delete all.** Deletes all appointments and tasks in the calendar.

Exchanging Calendar Entries

You can send and receive appointments and tasks using *Bluetooth* wireless technology, the infrared port or a text message.

To send an appointment or a task

1. Select **Send** in the list of options.
2. Select a transfer method.

Continue as described in “Connecting IR Devices” on page 55, “Sending Messages” on page 44 or “Sending and Receiving” on page 52.

You can send appointments and tasks to specific *Bluetooth* printers and have them printed out. Select the relevant printer in the list of devices.

You can also send daily, weekly and monthly overviews to specific *Bluetooth* printers and have the overviews printed out.

To send calendar views to a printer

1. Scroll to **Extras, YES, Calendar, YES, Send, YES**.
2. Select a view: **View today, View week** or **View month** and press **YES**.
3. Scroll to the day, week or month you want to print and press **YES**.
4. Scroll to **Send, YES, Via Bluetooth, YES**.

5. Select the printer in the list of devices and press **YES**.

When you receive an appointment or a task via a text message, you accept it by pressing **YES**. To be able to receive calendar items using the infrared port or *Bluetooth* wireless technology, you first need to select the **Receive** menu in order to activate the infrared port or to make the phone discoverable.

To receive an appointment or a task

1. Scroll to **Extras, YES, Calendar, YES, Receive, YES**.
2. Select a transfer method and press **YES**.
3. When you receive a calendar item, press **YES** to save it in the calendar.

If your calendar is full, you must remove calendar items before saving any new ones.

Synchronization

You can synchronize the calendar and contacts in your phone with the calendar and contacts in your PC. To do this, you first need to install a synchronization program on your PC. You can find such a program on the Ericsson CD that comes with your mobile phone.

Starting the Synchronization

You can synchronize using *Bluetooth* wireless technology, the infrared port or a cable. If you want to use the *Bluetooth* wireless technology, you must first pair your mobile phone with the other device. See “To initiate pairing with a device” on page 50.

To start the synchronization

1. Scroll to **Extras, YES, Synchronization, YES, Synchronize, YES**.
2. Select the synchronization method you wish to use and press **YES**.
 - If you select **Use Bluetooth**:
Select a device in the list, for example a PC (paired with your phone and with the synchronization program installed).
 - If you select **Use IR**:
Make sure the infrared port of the phone and the other device are facing each other.

Synchronization Sound

You can select whether you want the phone to make a sound when the synchronization is finished.

To turn the synchronization sound on or off

1. Scroll to **Extras, YES, Synchronization, YES, Sound, YES**.
2. Select **On** or **Off** and press **YES**.

Synchronization
1 Synchronize
2 Server settings
3 Sound

Setting up WAP

In order to browse via WAP, you must enter settings for a **data account** in your phone. The settings specify all the information your phone needs to communicate with a certain server on the Internet, for example, the address of that server. You can have several data accounts saved in your phone, with different settings for different purposes. For fast and efficient access, try the General Packet Radio Service (**GPRS**) as the access type.

In order to browse via WAP, you also need to enter settings for a **WAP profile** and select which WAP profile you want to use when browsing.

Note: *The settings may already be entered when you buy the phone, or you can receive the settings from your network operator or your Internet service provider. You can also receive settings from <http://mobileinternet.ericsson.com>.*

Data Account Settings

The main setting for a data account is the **access type** (connection method). You can choose between two access types:

- **GPRS** (General Packet Radio Service) **data**
GPRS allows you to be always online, yet pay only for the amount of data transmitted and not for the time you are connected. Please contact your network operator for charging details.
- **GSM data**
Normally, you pay for the time you are connected.

To create a data account

1. Scroll to **Settings, YES, Data comm., YES, Data accounts, YES, Add account?, YES.**
2. Enter a name for the data account.
3. Select an access type: **GPRS data** or **GSM data.**
4. Enter the settings that you have received from your operator.
For GPRS: access point name, user id and password.
For GSM data: phone number, user id and password.
Confirm each setting by pressing **YES.**
5. Scroll to **Save?,** press **YES.**

To enter additional settings for a data account

1. Scroll to **Settings, YES, Data comm., YES, Data accounts, YES.**
2. Select a data account and press **YES.**
3. Select **Edit.**
4. Select the setting you want to edit and press **YES.** Edit the setting, press **YES.**
5. Repeat step 4 for all the settings you want to edit.

Settings for GPRS:

APN address (Access point name address) – the address of the external data network you want to connect to, either an IP address or a text string.

User id – your user id to log on to the external data network.

Password – your password to log on to the external data network.

Passwd. request (Password request) – if this setting is on, you are asked for a password each time you log on to the external data network.

Pref. service (Preferred service) – if you want to be able to accept incoming calls during a GPRS session, select **Automatic.** If not, select **GPRS only, ✕.**

IP address – the IP address that the phone uses when communicating with the network. If you do not enter a value, the network provides you with a temporary IP address.

Advan. settings (Advanced settings) – these are optional. Consult your network operator.

Settings for GSM data:

Phone number – the phone number of your Internet service provider.

User id, Password, Passwd. request. Same as for GPRS above.

Data rate – select the speed you want for the connection.

Dial type – select analogue or ISDN connection.

If you want to change access type, you have to create a new data account and select the access type you want to use.



GPRS and GSM Data Settings

If you have selected GPRS as the access type, the Preferred mode should be set to **Automatic**. An icon may then appear in the display telling you that GPRS is within range. See “Icons” on page 131. If you have selected GSM data as the access type, you should select **GSM only** as the preferred mode. This setting is valid for all data accounts.

To select a preferred mode

1. Scroll to **Settings, YES, Data comm., YES, Pref. mode, YES**.
2. Select **Automatic** or **GSM only**.

Tip: *To see the status of GPRS coverage and connection, slide the volume key up or down from standby to enter the Status menu and then scroll to GPRS.*

WAP Profile Settings

When you browse WAP pages, you use a certain **WAP profile**. A WAP profile is a collection of settings that determines, for example, how you connect to the mobile Internet. You could, for example, have one WAP profile for mobile e-commerce and another one for general WAP browsing. You can have five WAP profiles. By switching WAP profile, you also switch settings in a simple way.

There are three ways in which WAP profile settings can be entered into your phone:

- The settings are already entered when you buy the phone.
- You receive the settings in a text message (over the air), for example, from <http://mobileinternet.ericsson.com>.
- You enter the settings manually.

Note: *You may not need to enter all the settings below. Contact your network operator or service provider (a distributor of WAP pages) before you start changing the settings yourself.*

To enter WAP profile settings manually

1. Make sure you have created a **data account** between your phone and the WAP gateway.
2. Scroll to **WAP services, YES, WAP settings, YES**.
3. Select the profile that you want to edit and press **YES**.
4. Scroll to **Rename, YES**. Enter a name for the profile.
5. Scroll to **Chg homepage, YES**. Enter the address of the WAP page you want to have as homepage.

6. Scroll to **Save to, YES**. Select if the bookmarks that you add during browsing should be available for all your WAP profiles or only for the WAP profile you are currently using.

7. Scroll to **Gateway, YES**.

8. For GPRS and GSM data, select **IP settings, YES**. Continue as described in “To enter IP settings” below.

For SMS, scroll to **Change type, YES, SMS, YES**. Then select **SMS settings, YES**. Continue as described in “To enter SMS settings” below.

To enter IP settings

1. Select **Connect using, YES**. Select the data account you want to use when browsing.

2. Scroll to **IP address, YES**. Enter the IP address of the WAP gateway.

3. Scroll to **User id, YES**. Enter your user id for the WAP gateway.

4. Scroll to **Password, YES**. Enter your password for the WAP gateway.

5. Scroll to **Data mode, YES**. Select a data connection mode, **YES**.

6. Scroll to **Security, YES**. Select **On** if you want a secure connection, or **Off** if you do not want a secure connection.

7. Scroll to **Show images, YES**. Select **On** if you want to view images while browsing, or **Off** if you do not want to view images while browsing.

8. Scroll to **Response timer, YES**. Enter a time limit in seconds after which a download attempt will stop.

To enter SMS settings

1. Select **Service centre, YES**. Enter the phone number of your network operator’s service centre.

2. Scroll to **SMS gateway, YES**. Enter the phone number of your network operator’s SMS gateway.

3. Scroll to **User id, YES**. Enter your user id for the WAP gateway.

4. Scroll to **Password, YES**. Enter your password for the WAP gateway.

5. Scroll to **Security, YES**. Select **On** if you want a secure connection, or **Off** if you do not want a secure connection.

6. Scroll to **Show images, YES**. Select **On** if you want to view images while browsing, or **Off** if you do not want to view images while browsing.

7. Scroll to **Response timer, YES**. Enter a time limit in seconds after which a download attempt will stop.

Note: *An IP address consists of four groups of digits, with a maximum of three in each group, for example 136.225.37.163. If any of the digit groups consists of only one or two digits, enter a leading zero (0) for each digit that is missing, 136.225.037.163.*

Before you start using the WAP browser, you must select which of your WAP profiles you want to use when browsing.

To select a WAP profile

1. Scroll to **WAP services, YES, Select profile, YES**.
2. Select a WAP profile and press **YES**.

WAP services
4 Enter address
5 Resume
6 Select profile
7 Clear cache

WAP

WAP (Wireless Application Protocol) is a global standard for advanced mobile services, for example, mobile Internet communication, mobile e-commerce and telephony services. WAP allows you to access certain services on the Internet such as banking services, news and reservation services from your mobile phone.

Note: *In order to access WAP services, you need a subscription that supports data transmission and WAP browsing.*

Before you start using the WAP browser, make sure you have created a data account, entered the WAP profile settings and selected a WAP profile. See “Setting up WAP” on page 62. For fast and efficient browsing, try the General Packet Radio Service (GPRS) as the access type.

Starting the WAP Browser

To start browsing

1. Scroll to **WAP services** and press **YES**.
2. Select one of the following ways to start browsing:
 - Open your homepage. Ericsson Mobile Internet is the homepage which is set when you buy your phone.
 - Go to one of your bookmarks. Scroll to **Bookmarks**, **YES**. Select a bookmark from the list and press **YES**.
 - Enter the address of a WAP page. Scroll to **Enter address**, **YES**. Enter the WAP address, for example: **mobileinternet.ericsson.com**. (You only need to enter a prefix if you want to use a protocol other than http, such as ftp://.)

Exiting the WAP Browser

To exit the browser

- Press and hold **NO**. **Remain connected?** appears. Press **NO**. If you want to leave the browser temporarily but stay on-line, press  and select **Go to menu**.

Options When Browsing

When browsing, you can reach different browsing options such as links or special features by pressing . The options may vary depending on the WAP page you are visiting.

The following options are always found:

- **Homepage** – go to the homepage of the current WAP profile.
- **Bookmarks** – add the page you are currently browsing to your list of bookmarks, or view the list of bookmarks for the WAP profile you are currently using.
Bookmarks which have been saved in a WAP profile other than the one you are currently using are in grey. To view all bookmarks, exit the browser and go to **WAP services, YES, Bookmarks, YES**.
- **Enter address** – enter the WAP address of a page you want to visit.
- **Send as link** – send a text message with a link to the current WAP page to another phone.
- **Reload** – refresh the contents of the WAP page.
- **Go to menu** – go back to the WAP services menu in order to access other phone menus. The connection to the Internet is not interrupted. When you want to start browsing again, scroll to **WAP services, YES, Resume, YES**.
- **Exit** – close down the WAP connection.
- **Status** – display the current status, for example how long you have been browsing.
- **New homepage** – set the current WAP page as the homepage for the WAP profile you are currently using.

Additional WAP Options

When not browsing, you can, for example, change the homepage, edit your bookmarks or clear the cache memory.

Changing the Homepage of a WAP Profile

When you buy your mobile phone, Ericsson Mobile Internet is set to be the homepage in each of the five WAP profiles that you have in your phone.

To change the homepage of a WAP profile

1. Scroll to **WAP services, YES, WAP settings, YES**.
2. Select the profile whose homepage you want to change, **YES**.
3. Scroll to **Chg homepage, YES**.

Mobile Internet
1 Go to bookmark
2 Edit bookmark
3 Delete
4 Send as link

4. Enter the name of the homepage, **YES**.
5. Enter the address of the homepage, **YES**.

Your List of Bookmarks

When you are not browsing, you can see all your WAP bookmarks in **Bookmarks**. You can have a maximum of 50 bookmarks.

To work with your bookmarks when not browsing

1. Scroll to **WAP services**, **YES**, **Bookmarks**, **YES**.
2. Select the bookmark you want to go to, edit or send, **YES**.
3. Select one of the following submenus and press **YES**:
 - **Go to bookmark**. Go to the marked WAP page.
 - **Edit bookmark**. Edit the name and/or the WAP address of the bookmark.
 - **Delete**. Delete the bookmark.
 - **Send as link**. This creates a text message in which the WAP address is sent as a link. You can add a comment if you wish.

Clearing Cache

You can clear the cache memory which contains previously visited WAP pages.

To clear the cache memory

1. Scroll to **WAP services**, **YES**, **Clear cache**, **YES**.
2. **Clear cache?** appears. Press **YES**.

Security

When you use certain WAP services, for example mobile e-commerce, you need a secure connection between your phone and the WAP gateway. If you are connected securely while browsing, an icon appears in the display.



To establish secure connections, you need to have **certificates** saved in your phone. A **trusted certificate** guarantees that a WAP site is genuine. If you have this type of certificate saved in your phone, it means you trust all WAP gateways that its supplier, for example a network operator, has certified.

You can find and download certificates from certain WAP pages. Ask your network operator or service provider for the WAP address. Certificates may already be saved in your phone when you buy it.



To download a certificate

1. Browse to the WAP page where the certificates are.
2. Click a suitable link and follow the instructions to download the certificate to your phone.

To check the certificates in your phone

- Scroll to **WAP services, YES, WAP settings, YES, Common, YES, Trusted certif, YES**.
A list of the available certificates is shown.

WAP Push Messages

A service provider can send, for example, updated news or new WAP settings to your phone in a **push message**.

There are two kinds of push messages:

- **Text messages** that inform you about a WAP page.
- **WAP pages** with the updated information appear, and the WAP browser starts automatically.

Note: *When receiving push messages as WAP pages, you are charged for the data connection initiated by the WAP browser until you press **NO** to close down the WAP connection.*

Accepting or Rejecting Push Messages

If you do not want to receive push messages, you can turn off the **Push access**. This setting is valid for all your WAP profiles.

To turn the push access on or off

1. Scroll to **WAP services, YES, WAP settings, YES, Common, YES, Push access, YES**.
2. Select **On** or **Off**.

Receiving Push Messages

When you receive a push message, it comes to the **Push inbox**.

When you have read the message, press **YES** and select one of the following:

- **Postpone**. Saves the push message so that you can load and see it later.
- **Load**. The browser starts and loads the pushed WAP page.
- **Delete**. Deletes the push message.

Data Calls

A data call is a call where information, for example, e-mail messages, is sent between computers or servers via the built-in modem in your phone. To be able to send and receive data calls, you need:

- the appropriate computer program, such as an e-mail program.
- a phone subscription that supports data transmission.

For detailed information, please consult your network operator. WAP browsing is a data call sent between your phone and a mobile Internet server, not involving any computer program. See “WAP” on page 67.

Sending Data Calls

Data calls are initiated from the appropriate computer program. To send data calls you need to connect your phone to a computer via *Bluetooth* wireless technology, an infrared port or a cable and then start the computer program.

Receiving Data Calls

If you have separate numbers for voice and data calls, your phone recognizes the type of call.

Receiving Data Calls – Separate Numbers

If your network and subscription support separate numbers for the different types of call, the display shows which type of call you are receiving.

To receive a data call

1. Connect your phone to the computer.
2. Answer the call from within the computer program (if it is not answered automatically).

Note: *You cannot answer an incoming data call by pressing the **YES** key on the phone, but you can reject the call by pressing **NO**.*

Receiving Data Calls – One Number

If you have a SIM card that does not support separate voice and data numbers, the phone does not recognize the type of incoming call. If you want to receive a voice or data call, you first have to set the phone to one of these options in the **Next incoming** sub-menu.



To receive a voice or data call

1. Scroll to **Call info, YES, Next call, YES, Next incoming, YES.**
2. Select the call type you want (**Voice** or **Data**) and press **YES** to confirm your choice.
3. Connect your phone to the computer.
4. Answer the call from within the program.

Once you have set your phone for a specific incoming call, it remains set until you change it.

Sending and Receiving E-mail from Your PC

You can use the phone's built-in modem to send or receive e-mail from your PC.

To send e-mail messages from your PC

1. Install modem drives on your PC for your phone's built-in modem. You do this from the CD that comes with your phone.
2. In the Dial-Up Networking service on your computer, select Ericsson R520 as the modem you wish to use.
3. Place your mobile phone next to your computer. Make sure it is connected according to the instructions for the transfer method you are using.
4. Start your e-mail program, then write and send a message.

To receive e-mail messages from your PC

1. See steps 1 and 2 above.
2. Start your e-mail program and open your Inbox to read your new e-mail messages.



Profiles

Your phone includes a number of pre-programmed profiles. A profile is a group of settings which suit a certain environment. Some phone accessories select a profile automatically. For example, when you place your phone in a car handsfree unit, the **In car** profile is chosen.

Selecting a Profile

There are seven pre-programmed profiles:

- **Normal**
- **Meeting**
- **In Car**
- **Outdoors**
- **Port h-free** (portable handsfree)
- **Home**
- **Office**

When you buy your phone, it is set to the **Normal** profile. If you select a profile other than **Normal**, the name of the profile is shown in standby.

A profile with no accessories associated, such as **Meeting** or **Normal**, must be chosen manually.

To select a profile

1. Scroll to **Settings**, **YES**, **Profiles**, **YES**, **Select profile**, **YES**.
2. Select a profile and press **YES**.

Using Your Voice

You can select a profile by using your voice, but first you need to activate the voice profile function and record a voice command. See “Changing Profiles” on page 78.

To select a profile using your voice

1. Press and hold **YES** until you hear a tone.
2. Release **YES** and say your voice command for the profile.

Tip: *You can make the phone remind you to switch profile, for example, before a meeting begins. See “Calendar Settings” on page 59.*

Profiles	
1	Select profile
2	View profile
3	Edit profile
4	Reset profiles

Changing the Profile Settings

You cannot create more profiles, but you can change the settings for a profile. Use the **View profile** function to see what settings are included in a certain profile.

To view your profiles

1. Scroll to **Settings, YES, Profiles, YES, Select profile, YES**.
2. Select the profile you want to view and press **YES**.
3. Scroll to **View profile** and press **YES**. The settings for the profile in use appear.

To change a profile setting

1. Scroll to **Settings, YES, Profiles, YES, Edit profile, YES**.
2. Select a setting and press **YES**.
3. Change the profile setting according to your wishes. The settings remain until you change them again.

To change the name of a profile

1. Scroll to **Settings, YES, Profiles, YES, Edit profile, YES, Profile name, YES**.
2. Enter a new name and press **YES**.

With the **Reset Profiles** function, you can change all profile settings back to the way they were when you bought your phone.

To reset the profile settings

1. Scroll to **Settings, YES, Profiles, YES, Reset profiles, YES**.
2. Answer **YES** if you are sure you want to reset all profiles.

Accessories

A specific profile is chosen automatically when you use the phone together with a certain accessory. Every time you disconnect your phone from the accessory, the profile is changed to the one which was active before.

Note: *Contact your local Ericsson retailer for more information about accessories.*

Adding Accessories to a Profile

You can add one or more accessories to any profile, except the **Normal** profile. For example, if you usually use a portable handsfree together with a specific charger, you may add the charger to the **Port h-free** profile. When you connect the phone to the charger, the phone recognizes it and switches profile automatically.

When you want to add an accessory to a specific profile, you must first activate that profile. See “To select a profile” on page 73.

To add an accessory to a profile

1. Scroll to **Settings, YES, Profiles, YES, Edit profile, YES, Accessories, YES.**

Now you are in the list of the accessories already associated with the profile.

2. Select **Add accessory?** and press **YES.**
3. Select an accessory and press **YES.**

Note: *An accessory cannot be associated with more than one profile.*

To remove an accessory from a profile

1. Scroll to **Settings, YES, Profiles, YES, Edit profile, YES, Accessories, YES.**

2. Scroll to the accessory that you want to remove and press **C**.
3. **Delete?** appears. Press **YES.**

Voice Control

With your phone, you can:

- voice dial - call someone by saying the name and number type
- answer and reject calls with your voice when using a handsfree kit
- change profile with your voice
- record or listen to voice memos by using voice commands
- activate the voice control by saying a “magic word”

You can save up to 50 voice commands altogether. When recording voice commands, make sure you are in a quiet environment.

Before Voice Dialling

Before you can start voice dialling, you need to turn on the voice dialling function and record your voice commands.

To turn voice dialling on and record number types

1. Scroll to **Settings, YES, Voice control, YES, Voice settings, YES, Voice dialling, YES,**
2. Select **On** and press **YES**. Now you are going to record a voice command for each number type you use with your phone book contacts, for example “home”, “mobile” and so on.
3. Instructions appear. Press **YES**.
4. Select a number type and press **YES**.
5. Lift the phone to your ear, wait for the tone and say the number type that you want to record. The voice command is played back to you.
6. Press **YES** to save the voice command. If the recording is not OK, press **NO** and repeat step 5.

You also need to record voice commands for each contact, that is the name, for example “John”.

To record a contact name

1. Scroll to **Settings, YES, Voice control, YES, Voice commands, YES, Contacts, YES, Add voice, YES.**
2. Enter the first letter of the contact name and press **YES**.
3. Select a contact and press **YES**.
4. Follow the instructions in the display.

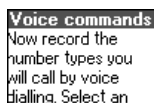
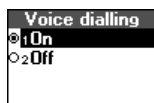



An icon appears next to the contact names which have a voice command.

Caller Name

You can choose whether you want to hear the recorded voice command for a name when you receive an incoming call.

To turn the caller name on or off

1. Scroll to **Settings, YES, Voice control, YES, Voice settings, YES, Caller name, YES.**
2. Select **On** or **Off.**

Voice Dialling

To make a call

1. From standby, press and hold **YES** until you hear a tone.
2. Release **YES**, lift the phone to your ear and say a name, for example “John”. The name is played back to you.
If you have saved several numbers for that contact:
 - After a second tone, say a number type that you have recorded earlier, for example “home”.

The number type is played back to you, and the call is connected.

From standby, you can also initiate voice dialling, voice profiles and voice control of voice memos by:

- sliding and holding the volume key.
- pressing and holding the handsfree button (when using a portable handsfree or a *Bluetooth* headset).
- saying the magic word. See “The Magic Word” on page 79.

Voice Answering

You can answer or reject incoming calls by using your voice, when using a portable handsfree, a car handsfree kit or the speakerphone.

To turn on voice answering and record voice answer commands

1. Scroll to **Settings, YES, Voice control, YES, Voice settings, YES, Voice answer, YES.**
2. Select the accessories you want to be able to use with voice answering by pressing **(*)0**.
3. Press **YES** to continue.
4. Lift the phone to your ear, wait for the tone and say “Answer”, or another word, and press **YES**. If the recording was not OK, press **NO** and repeat step 4.
5. Say “Busy”, or another word. Press **YES** to save your recordings.

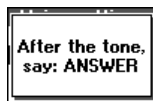



To answer an incoming call using voice commands

- When the phone rings, say “Answer”.
“Answer” is played back to you and the call is connected.

To reject an incoming call using voice commands

- When the phone rings, say “Busy”.
“Busy” is played back to you and the call is rejected. The caller hears a busy tone.

Changing Profiles

If you record voice commands for your profiles, you can change profile with your voice.

To turn on and record profile commands

1. Scroll to **Settings, YES, Voice control, YES, Voice settings, YES, Voice profiles, YES.**
2. Select **On** and press **YES.**
3. Instructions appear. Press **YES.**
4. Select a profile and press **YES.**
5. Lift the phone to your ear, wait for the tone and say the profile name. Repeat steps 4 and 5 to record voice commands for the other profiles.

To change a profile using voice commands

1. From standby, press and hold **YES** until you hear a tone.
2. Release **YES**, lift the phone to your ear and say the profile command for the required profile. The profile command is played back to you and the current profile is changed.

Recording Voice Memos

Instead of using the voice memo button, you can record voice commands to start a voice memo recording or to listen to voice memos.

To turn on and record voice memo commands

1. Scroll to **Settings, YES, Voice control, YES, Voice settings, YES, Voice memo, YES.**
2. Select **On** and press **YES.**
3. Instructions appear. Press **YES.**
4. Lift the phone to your ear, wait for the tone and say “Record”.
5. Say “Play” and press **YES** to save your recordings.

To start a voice memo recording using a voice command

1. From standby, press and hold **YES** until you hear a tone.
2. Release **YES**, lift the phone to your ear and say "Record". The voice command is played back to you and a tone indicates that the recording has begun.
To end the recording, press **YES**.

To listen to voice memo recordings using a voice command

1. From standby, press and hold **YES** until you hear a tone.
2. Release **YES**, lift the phone to your ear and say "Play". The voice command is played back to you.
3. Listen to your voice memo recordings. Press **NO** to stop.

The Magic Word

You can record a magic word and use it as a voice command to allow totally handsfree access to voice control. Instead of pressing and holding **YES**, you say the magic word and then one of your recorded voice commands. The magic word is especially suitable when driving a car with a car handsfree kit installed, because you use external power instead of the battery power of your phone. You can also use the magic word when the phone is connected to a portable handsfree or when the speakerphone is activated.

Tip: *Choose a long, unusual word which can easily be distinguished from ordinary background speech.*

To turn on and record the magic word

1. Scroll to **Settings, YES, Voice control, YES, Voice settings, YES, Magic word, YES**.
2. Select the accessories you want to be able to use with the magic word by pressing (*♯). Press **YES**.
3. Lift the phone to your ear, wait for the tone and say the magic word.

After the tone,
say your
magic word

Turn off the magic word when you no longer need totally handsfree access, in order to save battery power.

You can use the magic word whenever the speakerphone function is activated, but first you need to select the **speaker mode**.

To select the speaker mode

1. Scroll to **Settings, YES, Voice control, YES, Voice settings, YES, Magic word, YES**.
2. Select **Speaker mode** by pressing (*♯). Press **YES**.

Editing Your Voice Commands

In **Voice commands** you find all your voice commands. You can keep them up to date by re-recording them or deleting the ones you do not use.

To re-record a voice command

1. Scroll to **Settings, YES, Voice control, YES, Voice commands, YES**.
2. Select the type of voice command and press **YES**.
3. Select a voice command and press **YES**.
4. Select **Replace voice** and press **YES**.
To listen to a recorded voice command, select **Play voice**.
5. Lift the phone to your ear, wait for the tone and say the command.

You can also edit the voice command for a contact name in **Edit contact** in the **Phone book** menu.

Problems when Recording

If your phone cannot detect speech, one of the following might have happened:

- you spoke too softly – try speaking more loudly
- you held the phone too far away – hold it as you do during a call
- the voice command was too short – it should be around one second long
- you spoke too late or too soon – speak immediately after the tone

Voice Memo

With the voice memo function, you can record up to 90 seconds of your own messages or parts of calls.

Recording Voice Memos

The voice memo function is always available. The voice memos are saved in your mobile phone and can be accessed even if you change your SIM card.

To record a voice memo

- Press the voice memo button until you hear a tone and then release it. When the recording starts, the display shows **Recording** together with the remaining recording time.

To end the recording

- Press the voice memo button. The display shows **Voice memo saved**.

Tip: *You can start recording or listening to voice memos with a voice command. See “Recording Voice Memos” on page 78.*

The recording stops automatically if you receive an incoming call or when the call ends. You hear a tone five seconds before the voice memory is full.

Who to Record During Calls?

If a call is in progress and you start recording a voice memo, your phone starts recording the other person by default. You can choose to record either yourself or the person you are talking to during a call.

To select who to record

1. Scroll to **Extras, YES, Voice memo, YES, During calls, YES**.
2. Select **Record myself** or **Record other** and press **YES**.





Note: *In some countries you are required by law to inform the person you are talking to that you are recording him/her.*



Listening to Voice Memos

You can listen to your voice memos at any time, except during a call.



To listen to your voice memos

1. Press the voice memo button.
2. Scroll to the voice memo you wish to hear.
3. Press the voice memo button. If you want to:
 - Pause, press **YES**. Press **YES** again to play
 - go to next or previous: press  or , respectively.
 - go fast forward or rewind: press and hold  or , respectively.
4. Press **NO** to stop playback.

Tip: *To see how many seconds you have left for recording, scroll to the memory indicator bar at the top of the Memo list and press **YES**.*

Editing Voice Memos

To erase or rename a voice memo

1. Briefly press the voice memo button.
2. Use  to scroll to the voice memo you wish to erase or rename.
3. Press  when the voice memo is highlighted.
4. Select **Erase** or **Rename** and press **YES**.

You can also erase or rename a voice memo when you pause during playback.

To erase all voice memos

- Scroll to **Extras, YES, Voice memo, YES, Erase all, YES**.

Recording Quality

In standby mode, you can record your voice memo in two different modes. You can choose to record either 36 seconds of high quality sound, or 92 seconds of normal quality sound.

To set the recording quality

1. Scroll to **Extras, YES, Voice memo, YES, Set quality, YES**.
2. Select a recording quality and press **YES**.

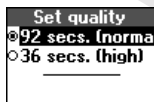

Settings

You can choose to show the date, time or length of the voice memo.

To set the view of your voice memos

1. Scroll to **Extras, YES, Voice memo, YES, Set view, YES.**
2. Scroll to **Date recorded** and press **(*)0** if you do not want this information to be shown. The tick in the box disappears. Press **(*)0** again if you want the information to be shown. The tick reappears. Repeat the procedure for **Time recorded** and **Length**.
3. Press **YES**.

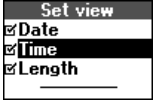

Voice Mail Service



The answering service of your network allows callers to leave a voice message when you cannot answer your calls.

Some operators inform you by sending a specific **Voice mail** indication. If this is the case, the voice mail icon appears in the display. Most operators, however, inform you by sending a text message, asking you to call your **Voice mail service**.

Calling Your Voice Mail

You can save the number of your voice mail service to be able to call your voice mail service by simply pressing and holding **1**. The number is provided by your network operator.

To save your voice mail number

1. Scroll to **Messages, YES, Options, YES, Voice mailno., YES**.
2. Enter your voice mail number and press **YES**.

Note: *The number of your voice mail service may be different if you are calling from a network that is not your home network.*

When you receive a voice mail, your phone beeps and the message **New voice mail** appears in the display (only if you receive the specific voice mail indication). If you want to check your voice mail now, press **YES** to call your voice mail service.

If you press **NO**, you can call your voice mail service later to listen to your recorded messages.

To call your voice mail service

- Press and hold **1** from standby mode, or:
 - Scroll to **Messages, YES, Call voice mail, YES**.

Message Alert Signal

You can change the signal that notifies you of a new message.

To change the message alert signal

1. Scroll to **Messages, YES, Options, YES, Message alert, YES**.
2. Select a signal and press **YES**.

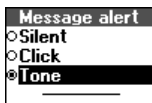
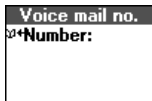

Diverting Calls

You can use the **Divert calls** service to divert incoming calls to another phone number when you are unable to answer.

For voice calls, you can choose between the following divert alternatives:

- **Divert always** - divert all voice calls.
- **When busy** - divert calls if you are already on the phone.
- **No reply** - divert calls that you do not answer within a specified time limit.
- **Not reachable** - divert calls if your phone is turned off or if you are unreachable.

If you subscribe to the Two line service, you may set different divert phone numbers for your two voice lines, line 1 and line 2. You will then have two divert alternatives in the menu, **All line 1 calls** and **All line 2 calls**, instead of **Divert always**.

Tip: *If you place your phone in an Ericsson Desktop Charger, your calls may be diverted automatically.*

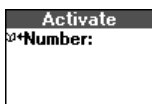
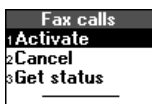
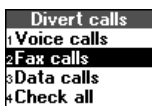

Activating Divert Calls

To turn on the Divert calls function

1. Scroll to **Settings, YES, Call options, YES, Divert calls, YES**.
2. Select a call type and press **YES**.
3. Select a divert alternative and press **YES**.
4. Select **Activate** and press **YES**.
5. Enter the phone number, including the area code, to which you want your calls to be diverted and then press **YES**.

Note: *When the Restricted calls function is on, some Divert calls options cannot be activated.*

Cancelling Divert Calls

To cancel Divert calls

1. Scroll to **Settings, YES, Call options, YES, Divert calls, YES.**
2. Select a call type and press **YES.**
3. Scroll to the divert you want to cancel and press **YES.**
4. Select **Cancel** and press **YES.**

Checking Divert Status

To check the status of Divert calls

1. Scroll to **Settings, YES, Call options, YES, Divert calls, YES.**
2. Select a call type and press **YES.**
3. Scroll to the divert you want to check and press **YES.**
4. Select **Get status** and press **YES.**

To check the status of all Divert calls

- Scroll to **Settings, YES, Call options, YES, Divert calls, YES, Check all, YES.**

More than One Call

You can handle more than one call simultaneously. For example, you can put an ongoing call on hold, while you make or answer a second call, and then switch between the two calls.

You can also set up a **Conference call** to have a joint conversation with up to four other people.

Note: *Depending on whether a call is ongoing or not, either the Call info menu or the Ongoing call menu is shown.*

You can also reach the different options described below, for example, to hold a call or switch calls, by pressing .

Call Waiting Service

If you wish to be able to receive a second call while another call is in progress, you must turn on the **Call waiting** service.

Note: *If you are engaged in a data call, any other incoming calls are rejected.*

To turn on the Call waiting service

- Scroll to **Settings, YES, Call options, YES, Call waiting, YES, Activate, YES**. There may be a short delay before the network responds.

To cancel the Call waiting service

- Scroll to **Settings, YES, Call options, YES, Call waiting, YES, Cancel, YES**.

To check whether the Call waiting service is on or not

- Scroll to **Settings, YES, Call options, YES, Call waiting, YES, Get status, YES**.

Making a Second Call

You can only put one call on hold while you make a second call.

To make a second call

1. Put the current call on hold by pressing **YES**.
2. Enter the number you wish to call and press **YES** or press and hold  to retrieve the number from your phone book.



Receiving a Second Call

If the **Call waiting** service is on, you hear a tone in the earpiece if you receive a second call. The number or name of the caller is normally shown at the top of the display together with a list of the alternatives: **Answer**, **Busy** and **Release&answer**. If the incoming call is a restricted number, the display shows **Withheld**.

To put the ongoing call on hold and answer the waiting call

- Press **YES** to answer the waiting call.
The current call is now put on hold.

To continue the ongoing call and reject the waiting call

- Select **Busy** and press **YES**.
The waiting call is rejected.

Note: *If Divert when busy is on, the waiting call is diverted to the number you have specified.*

To end the ongoing call and answer the waiting call

- Select **Release&answer** and press **YES**.

Handling Two Calls

When you have one active call and one call on hold, you can do one of the following:

To switch between the two calls

- Press **YES**.

To end the active call and return to the call on hold

1. Press **NO**. The question **Retrieve call?** appears.
2. Press **YES**.

If you press **NO**, the call on hold is also ended.

To end both calls

- Scroll to **Ongoing call**, **YES**, **Release all**, **YES**.

To connect the two calls

- Scroll to **Ongoing call**, **YES**, **Transfer call**, **YES**.

The two calls are now connected to each other, and you are disconnected from both. Please contact your network operator for charging details.

To join the two calls into a Conference call

- Scroll to **Ongoing call**, **YES**, **Join calls**, **YES**.

See 'Conference calls' below.

Receiving a Third Call

If the Call waiting service is on, you may receive a third call when you have one active call and a second call on hold. From now on, you cannot answer any more calls without disconnecting one, unless you create a conference call. You hear a tone in the earpiece and **Busy** and **Release&answer** appear in the display.

To end the ongoing call and accept the waiting call

- Select **Release&answer** and press **YES**.

The waiting call becomes active and the call on hold remains on hold.

To reject the waiting call

- Select **Busy** and press **YES**. The caller hears a busy tone. The third call is rejected.

Conference Calls

In a conference call, you can have a joint conversation with up to four other people.

Creating a Conference Call

To create a conference call, you must have one active call and one call on hold.

To join the two calls into a conference call

- Scroll to **Ongoing call, YES, Join calls, YES**.

Adding New Participants

You can put the conference group on hold and then add new participants.

To add a new participant

1. Press **YES** to put the conference group on hold.
2. Call the next person you wish to include in the conference group.
3. Scroll to **Ongoing call, YES, Join calls, YES**.

To check the participants in the conference group

1. Scroll to **Ongoing call, YES, Parties in conf, YES**.

The first participant's phone number is displayed, if available. Otherwise the display shows part 1, 2 etc.

2. Scroll with  to check the other participants.

Having a Private Conversation

You can have a private conversation with one of the participants and put the other participants on hold.

To extract a participant

1. Scroll to **Ongoing call, YES, Extract part, YES**.
2. Select the participant and press **YES**.

You may now have a private conversation with the participant.

To rejoin the participant to the conference group

- Scroll to **Ongoing call, YES, Join calls, YES**.

Releasing Participants

You can release participants from the conference group one by one or all at once.

To release a participant

1. Scroll to **Ongoing call, YES, Release part, YES**.
2. Select the participant and press **YES**.

To release all participants

- Scroll to **Ongoing call, YES, Release all, YES**.

Making a Call during a Conference Call

You can put the conference group on hold and make another call. You can then switch between the new call and the conference call.

To put the conference group on hold and make a new call

1. Press **YES**.
2. Enter the number you wish to call and press **YES**.

To switch between the new call and the conference group

- Press **YES**.

To end the new call and return to the conference group

- Press **NO** and then **YES**.

Ending the Conference Call

- Press **NO**.

Call Time and Call Cost

During a call, the duration is shown in the display. If you subscribe to cost information, the call cost (or the number of call units) is displayed instead.

Checking the Time or Cost

The **Call info** menu allows you to check the total time or cost of your calls. You can also check the call time and cost by pressing .

To check the call time of the last call

- Scroll to **Call info, YES, Call timers, YES, Last Call, YES.**

To check the call time of your outgoing calls

- Scroll to **Call info, YES, Call timers, YES, Outgoing time, YES.**

To check the total call time

- Scroll to **Call info, YES, Call timers, YES, Total time, YES.**

To reset the total call time

1. Scroll to **Call info, YES, Call timers, YES, Reset timers, YES.**
2. Select **Total time** or **Outgoing time** and press **YES.**

To check the cost of the last call

- Scroll to **Call info, YES, Call costs, YES, Last call, YES.**

To check the total call cost

- Scroll to **Call info, YES, Call costs, YES, Total cost, YES.**

To reset the total call cost

1. Scroll to **Call info, YES, Call costs, YES, Clear total cost, YES.**
2. Press **YES** to confirm your choice.

Note: *If you subscribe to cost information, you must enter your PIN2 to clear the cost or time counter. For details about PIN2, please contact your network operator.*

Setting the Call Cost

You can use the **Tariff** function to specify the price per call unit. The price entered is saved on your SIM card.

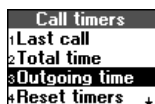

Note: *If you do not specify a price per call unit, the number of call units is displayed during a call, and in Last call and Total cost in the Call info menu.*

To enter the price per call unit

1. Scroll to **Call info, YES, Call costs, YES, Set tariff, YES.**
2. Enter your PIN2 and press **YES.**
3. Select **Change tariff** and press **YES.**
4. Enter the currency you want, for example GBP for Pounds Sterling, and press **YES.**
5. Enter the price per call unit, for example 0.75, and press **YES.** To enter a decimal point, press ***0.**

To revert to call units

1. Scroll to **Call info, YES Call costs, YES, Set tariff, YES.**
2. Enter your PIN2 and press **YES.**
3. Select **Units** and press **YES.**

Credit Limit for Calls

You can enter a total amount of money that can be used for making calls. When the amount reaches zero, no more calls can be made.

To set a specific credit limit

1. Scroll to **Call info, YES, Call costs, YES, Set credit, YES.**
2. Enter your PIN2 and press **YES.**
3. Select **Change credit** and press **YES.**
4. Enter the amount, for example 30 pounds, and press **YES.**

To set unlimited credit

1. Scroll to **Call info, YES, Call costs, YES, Set credit, YES.**
2. Enter your PIN2 and press **YES.**
3. Select **Unlimited** and press **YES.**

Minute Minder

If you turn on the minute minder, you hear a beep once every minute during a call as a reminder of the duration of the ongoing call.

To turn the minute minder on or off

1. Scroll to **Call info, YES, Call timers, YES, Minute minder, YES.**
2. Select **On** or **Off** and press **YES.**

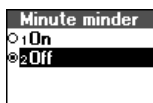

Networks

Searching for Networks

When you turn on the phone, it searches for the last accessed network. If this is not within range, you may use another network, provided your home network has an agreement that allows you to do so. This is called roaming.

To start an automatic network search

- Scroll to **Settings, YES, Networks, YES, New search, YES**.
The phone automatically starts searching for a network according to the list of preferred networks saved on your SIM card.

To select a network

1. Scroll to **Settings, YES, Networks, YES, Select network, YES**.
2. Select a network and press **YES**.

The network you are currently using is marked with a filled button. The following information is also shown:

The display shows... meaning...



Your home network is within range.



The name of the network is included in a list of preferred networks on your SIM card. You can use this network.



The name of the network is included in a list of forbidden networks on your SIM card, and can only be used for emergency calls.

All other networks without any icons are available.

If your home network and a forbidden network come to an agreement that allows you to use the forbidden network, you can select this network even though the message **Forbidden** is displayed.



Preferred Networks

You can create and edit a list that defines the order in which your phone selects a network during an automatic network search, when your home network is not within range.



The number of networks that can be saved in the list depends on your SIM card.

To view the list of networks

1. Scroll to **Settings, YES, Networks, YES, Preferred nets, YES**.
The name of the first network is displayed.
Use  or  to scroll through the networks in the list.

To see a network's full name

1. Scroll to **Settings, YES, Networks, YES, Preferred nets, YES**.
2. Scroll to a network and press **YES**.
3. Select **Full name** and press **YES**.

To add a network to the list

1. Scroll to **Settings, YES, Networks, YES, Preferred nets, YES, Add new?, YES**.
2. Scroll to a network and press **YES**.
If the network you want does not appear in the list, scroll to **Other** and press **YES**. Enter the three-digit country number and the two-digit network number and press **YES**. For details, please contact your network operator.
3. Enter a position number and press **YES**.

To delete a network from the list

1. Scroll to **Settings, YES, Networks, YES, Preferred nets, YES**.
2. Scroll to a network and press , **YES**.

To rearrange the list

1. Scroll to **Settings, YES, Networks, YES, Preferred nets, YES**.
2. Scroll to a network and press **YES**.
3. Select **Change priority** and press **YES**.
4. Enter the new position within the list and press **YES**.

Search Modes

When you turn on your phone, it searches for a network. This can be done in two different ways:

Automatic search mode means that your phone first searches for the last accessed network. If this is not available, it automatically searches for another available network within range.

Manual search mode means that your phone first searches for the last accessed network. If this is not available, the question **Select net?** appears. You then need to choose a network as described in “Searching for Networks” on page 93.



To turn on the automatic or manual search mode

1. Scroll to **Settings**, **YES**, **Networks**, **YES**, **Search mode**, **YES**.
2. Select **Automatic** or **Manual**, and press **YES**.

Not for Commercial Use
Ericsson Mobile Communications AB

Security

You can protect your phone and subscription from unauthorized use in several ways. For example, you can lock the phone or subscribe to specific services such as the Restrict Calls service.

Locking the SIM Card

The SIM card lock protects your subscription, but not your phone itself, from unauthorized use. If you change SIM cards, the phone still works with the new SIM card.

Most SIM cards are locked at the time of purchase. If the SIM card lock is on, you have to enter your PIN (Personal Identity Number) every time you turn on your phone. If you enter your PIN incorrectly three times in a row, the SIM card is blocked. This is indicated by the message **PIN blocked**. To unblock it you need to enter your PUK (Personal Unblocking Key). Your PIN and your PUK are supplied by your network operator.

To unblock your SIM card

1. **PIN blocked** appears.
2. Enter your PUK (or PUK2) and press **YES**.
3. Enter a new four- to eight-digit PIN (or PIN2) and press **YES**.
4. Re-enter the new PIN (or PIN2) to confirm and press **YES**.

Note: *If you enter the wrong PUK ten times in a row, your card is permanently blocked. If this happens, you should contact your network operator.*

To change your PIN

1. Scroll to **Settings, YES, Locks, YES, SIM lock, YES, Change PIN, YES**.
2. Enter your old PIN and press **YES**.
3. Enter your new PIN and press **YES**.
4. Re-enter your new PIN to confirm and press **YES**.

To change your PIN 2

1. Scroll to **Settings, YES, Locks, YES, SIM lock, YES, Change PIN2, YES**.
2. Proceed as described in “To change your PIN” above.

Change PIN
Old PIN:



To turn the SIM card lock on or off

1. Scroll to **Settings, YES, Locks, YES, SIM lock, YES, Protection, YES.**
2. Select **On** or **Off**, enter your PIN and press **YES.**
The message **Locked** or **Unlocked** confirms that the card lock has now been turned on or off.

Locking the Phone

The phone lock protects the phone against unauthorized use if it is stolen and the SIM card exchanged. It is not on when you buy the phone. We recommend that you change the phone lock code (**0000**) to any four- to eight-digit personal code. The phone lock can be **On**, **Automatic** or **Off**.

To set the phone lock to on, automatic or off

1. Scroll to **Settings, YES, Locks, YES, Phone lock, YES, Protection, YES.**
2. Select **On**, **Automatic** or **Off**. The current setting is not available in the list.
3. Enter the phone lock code and press **YES.**



If the phone lock is **On**, the message **Phone locked Phone lock code:** appears each time you turn on the phone. You have to enter your code followed by **YES** to use your phone.

If the phone lock is set to **Automatic**, you do not need to enter your phone lock code until a different SIM card is inserted in the phone.

Changing the phone lock code

1. Scroll to **Settings, YES, Locks, YES, Phone lock, YES, Change code, YES.**
2. Follow the steps described in “To change your PIN” on page 96.

Note: *If you should forget your new code, you have to hand in your phone to your local Ericsson retailer or service point to have the phone unlocked.*

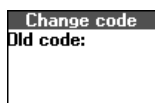

Locking the Keypad

With the keypad lock on, you avoid accidental dialling, for example, if you keep your phone in your pocket. You can set the keypad lock manually or select the automatic keylock. Automatic keylock means that if no keys are pressed in 25 seconds, the keypad is locked.



Note: You can call the emergency number even if the keypad is locked. If the phone alarm rings, you can turn it off by pressing any key.

The keypad is locked until you:

- answer an incoming call.
- read an incoming message.
- replace the battery.
- unlock the keypad.

To lock the keypad manually

1. From standby, press .
2. Select **Turn on keypad** and press **YES**.

To unlock the keypad manually

- Press . The question **Turn off keypad?** appears. Press **YES**.

To set the automatic keylock on or off

1. Scroll to **Settings, YES, Locks, YES, Auto keylock, YES**.
2. Select **On** or **Off** and press **YES**.

Note: The keypad lock is always turned off if the phone is connected to a car handsfree.

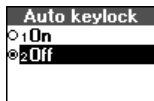

Restricting Calls

You can use the **Restrict calls** service to restrict certain types of calls that can be made and received. You need a password, which comes with your subscription from the network operator, to turn a call restriction on or off.

The following calls can be restricted:

- all outgoing calls, **All outgoing**
- all outgoing international calls, **Outgoing Intl**
- all outgoing international calls except to your home country, **Outg Intl roam**
- all incoming calls, **All incoming**
- all incoming calls when you are abroad (when roaming), **Inc when roam**

To turn a call restriction on or off

1. Scroll to **Settings, YES, Call options, YES, Restrict calls, YES**.
2. Scroll to an option and press **YES**.
3. Select **Activate** or **Cancel** and press **YES**.
4. Enter your password and press **YES**.

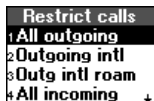

- To cancel all call restrictions, select **Cancel all**.
- To check the status of a call restriction, select the call restriction option and then **Get status**.
- To change the password, select **Change passwd**.

Note: *If you divert incoming calls, you cannot turn on some Restrict calls options.*

Fixed Dialling

The **Fixed dialling** function allows calls to be made only to certain numbers saved on the SIM card. If an attempt is made to call other numbers, the message **Number not permitted** appears in the display. Fixed dialling requires a SIM card that allows fixed numbers to be saved. The fixed numbers are protected by your PIN2.

Note: *Emergency calls can still be made, even when Fixed dialling is on.*

To turn Fixed dialling on or off

1. Scroll to **Phone book, YES, Options, YES, Fixed dialling, YES**.
2. Enter your PIN2 and press **YES**.
3. Select **On** or **Off** and press **YES**.

To save fixed numbers

1. Scroll to **Phone book, YES, Special numbers, YES, Fixed numbers, YES, Add new?, YES**.
2. Enter your PIN2 and press **YES**.
3. Enter the fixed number and press **YES**.
4. Enter the name you want to associate with the number and press **YES**.

Closed User Groups

The **Closed user group** function is another way of lowering call costs. On some networks it is cheaper to make calls within a call group. Your network operator can place certain numbers in groups. You can have a maximum of 10 groups.

To add a closed user group

1. Scroll to **Settings, YES, Call options, YES, Closed groups, YES, Edit list, YES**.
2. Scroll to **Add new?** and press **YES**.
3. Enter the name of the user group and press **YES**.

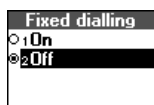

4. Enter the index number of the group and press **YES**.
The index numbers are provided by your network operator.

To activate a closed user group

1. Scroll to **Settings, YES, Call options, YES, Closed groups, YES, Edit list, YES**.
2. Scroll to the group you want and press **YES**.
3. Select **Activate** and press **YES**.

Calls can be made only within the selected user group.

To call outside closed user groups

1. Scroll to **Settings, YES, Call options, YES, Closed groups, YES, Open calls, YES**.
2. Select **On** and press **YES**.

Accepting Calls

With the **Accept calls** service, you can choose to receive calls only from certain numbers that you have in your phone book. Other calls are automatically rejected by a busy tone. You have to save the numbers that you want to receive in an **Accepted list**. The rejected calls are saved in the **Call list** in the **Call info** menu.

To add numbers to the list of accepted callers

1. Scroll to **Settings, YES, Call options, YES, Accept calls, YES, Edit list, YES, Add to list?, YES**.
2. Select **Phone book** (you can add a contact's number) or **Groups** (you can add a group).
3. Enter the first letter of the contact or group and press **YES**.
4. Scroll to the number or group you want to add and press **YES**.

To set the accept options

1. Scroll to **Settings, YES, Call options, YES, Accept calls, YES, Accept options, YES**.
2. Select one of the following:
 - **From list** - you only receive calls from callers in the **Accepted list**. All other incoming calls will be rejected. The caller hears a busy tone and you get no indication of incoming calls.
 - **From no one** - All incoming calls are rejected.
 - **From all** - You receive all calls as normal.

Code Memo

Instead of having to remember all the different security codes for credit cards etc, you can save them in the Code memo in your phone. Then all you need to remember is the password to open the Code memo. You can save a maximum of 10 codes in the Code memo.

Checkword and Security

To confirm that you have entered the correct password for the Code memo and to prevent unauthorized access to your codes, you must enter a **Checkword**. When you enter your password to open the Code memo, the checkword is shown for a short time. If the password is correct, the correct codes are shown. If you enter the incorrect password, the checkword and the codes that are shown are also incorrect.

Factors strengthening the security of the Code memo function are:

- You get no feedback about whether the password is correct, except for the checkword, and only you know the checkword.
- All codes are encrypted in the mobile phone.
- When you access your codes, they are shown for a limited time only.

Using Code Memo

To open Code memo for the first time

1. Scroll to **Extras, YES, Code memo, YES**.
A message with instructions appears.
2. Press **YES**.
3. Enter a four-digit password to open Code memo and press **YES**.
4. Re-enter the new password to confirm.
5. Enter a checkword (maximum 15 characters) and press **YES**.
The checkword can consist of both letters and numbers. To enter a number, press and hold the key.

To add a new code

1. Scroll to **Extras, YES, Code memo, YES**.
2. Enter your password.
3. Select **Add new code?** and press **YES**.

4. Enter a name associated with the code, for example, the name of the credit card company, and press **YES**.
5. Enter the code and press **YES**.

To open Code memo

1. Scroll to **Extras, YES, Code memo, YES**.
2. Enter your password and press **YES**.

Your entered checkword appears. When the decryption process has finished, your codes are shown.

Deleting and Editing Codes

To delete a single code

1. Open Code memo as described above.
2. Scroll to the code you want to delete and press **C**.
3. **Delete?** appears. Press **YES**.

To edit a code

1. Open Code memo as described above.
2. Scroll to the code you want to edit and press **YES**. Press **YES** again.
3. Select **Edit** and press **YES**.
4. Enter the name and press **YES**, enter the code and press **YES**.

Changing the Password

1. Open Code memo as described above.
2. Scroll to **Options, YES, Chg password, YES**.
3. Enter your new password and press **YES**.
4. Re-enter the new password and press **YES**.
5. Enter a checkword and press **YES**.

Forgot Your Password?

If you forget your password, just enter any password to access the Code memo function. The checkword and codes that are then shown are incorrect. You must now reset the Code memo.

To reset Code memo

1. Scroll to **Options, YES, Reset, YES**.
2. **Reset code memo?** appears. Press **YES**.

The Code memo is reset and all entries are cleared. The next time you enter the Code memo, you must start at “To open Code memo for the first time” on page 101.

Two Voice Lines

If your subscription supports the **Two line service**, your phone has two voice lines with different phone numbers, separate bills and perhaps different subscription services. This is useful if, for example, you want to keep business calls and private calls on separate lines. You may have different settings for each line, for example, the ring signal or divert calls. You may also have separate voice mail numbers for each phone line, if this is supported by your subscription. Some operators may show the call time or call cost for each line separately.

Note: *The Bluetooth headset does not work on line 2.*

Changing the Name

When you buy your phone, the names of the lines are normally line 1 and line 2, but you can change their names.

To change the name of a line

1. Scroll to **Settings, YES, Display, YES, Edit line tags, YES.**
2. Select a line and press **YES.**
3. Enter a new name and press **YES.**

Changing Lines

Once you have chosen a line, all outgoing calls are made on this line until you change it again. An icon indicates the line currently chosen for outgoing calls.

Note: *Incoming calls can be received on both lines, irrespective of the line currently chosen.*

To change phone lines

1. Scroll to **Call info, YES, Next call, YES.**
2. Select **Switch to line 1** or **Switch to line 2** and press **YES.**

Locking One Line

You can choose to lock one of the lines, so that it cannot be used unless you enter the PIN2.

To lock a phone line

1. Scroll to **Settings, YES, Locks, YES**.
2. Select the phone line you want to lock: **Lock line 1** or **Lock line 2**. Press **YES**.
3. Enter your PIN2 and press **YES**.

To unlock a phone line

1. Scroll to **Settings, YES, Locks, YES**.
2. Select the phone line you want to unlock: **Unlock line 1** or **Unlock line 2**. Press **YES**.
3. Enter your PIN2 and press **YES**.

Calling Card Calls

When making international or long distance calls, you may want to use the calling card service to redirect the charges to a credit card account, instead of your normal account.

Note: *You cannot use the calling card service when making a data call.*

Calling Card Service

To be able to make calling card calls, you need to turn on the service.

To turn on the calling card service

1. Scroll to **Phone book, YES, Options, YES, Set callingcards, YES.**
2. Enter your phone lock code (0000) and press **YES.**
3. Select **On** and press **YES.**
The Calling card service is now on and the sub-menu **Calling cards** is available in the **Phone book** menu.

Saving Calling Card Numbers

You can save two calling card numbers in your phone.

To save a card number

1. Scroll to **Phone book, YES, Calling cards, YES.**
2. Enter your phone lock code and press **YES.**
3. Select **Add new?** and press **YES.**
4. Enter the access number of the calling card server and press **YES.**
5. Enter a name that you want to associate with your calling card server and press **YES.**
6. Enter the verification code of the calling card server and press **YES.**
7. Select which you want to send first - the number that you want to call or the verification code - and press **YES** to confirm your choice.

Note: *Verification codes are provided by your network operator.*

Calling cards
Phone lock code:

To delete a card number

1. Scroll to **Phone book, YES, Calling cards, YES**.
2. Scroll to the card number that you want to delete and press **C**.
3. Press **YES**.

To edit a card number

1. Scroll to **Phone book, YES, Calling cards, YES**.
2. Scroll to the card number that you want to edit and press **YES**.
3. Select **Edit** and edit the card number.
4. Press **YES** to confirm the new number.

Choosing a Card

If you have saved two card numbers, you must choose which card you want to use before making a calling card call.

To select a card

1. Scroll to **Phone book, YES, Calling cards, YES**.
2. Enter your phone lock code and press **YES**.
3. Select the card that you want to use and press **YES**.
4. Select **Activate card** and press **YES**.

Making a Calling Card Call

1. Enter the phone number you wish to call or retrieve it from the phone book by pressing and holding **▶**.
2. Press and hold **YES**.
The access number of the calling card server is called. During the connecting phase, you are asked to send the phone number that you want to call and the verification code, in the order chosen earlier (see above).
3. Press **YES** when the display shows **Send** or wait a few seconds and the number and code are sent automatically.

Games

Your phone includes two games: **Tennis** and **Erix**.

Tennis

You can play **Tennis** by yourself or against a user of another R520 phone using *Bluetooth* wireless technology or the infrared port. You play seven sets.

Tip: Read about “*Bluetooth™ Wireless Technology*” on page 49 and “*Infrared Port*” on page 54.

To start Tennis

1. Scroll to **Extras, YES, Games, YES, Tennis, YES.**
2. To start a new game, press **1**.
(Press **2** to resume a game and press **3** for help.)
3. If you want to have sound effects, press **1**. If not, press **2**.
4. Select how you want to play:
 - **Single** – you play against the phone: select difficulty level by pressing **1** or **2**. Press **1** and start playing.
 - **Two, one phone** – you and another person play against each other on the same phone: press **2** and start playing.
 - **Two, two phones** – you and another person play against each other on your phones via *Bluetooth* wireless technology or via the infrared port: press **3**.

If you select **Two, two phones**, proceed as follows:

5. Select a transfer method by pressing **1 (IR)** or **2 (Bluetooth)**.
6. Select if you want to initiate a game or if you want to join a game:
 - **Invite others** – your phone searches for other nearby players who have selected **Accept others** (see below): press **1**.
When a player is found, the game starts automatically.
 - **Accept others** – your phone waits to be found by another player who has selected **Invite others** to initiate a game: press **2**.
7. When the phones have found each other, start playing.



To control Tennis

You are the tennis player on the left.

- **1** or **2** = move the tennis player up
- **4**, **5**, **7** or **8** = move the tennis player down

If two people play on the same phone, the tennis player on the right controls the game as follows:

- **3** = up
- **6** or **9** = down

Erix

The object of Erix is to fill the display. You draw a line and when the line is connected at both ends, the contained area is filled. When you have filled approximately 75% of the display you move up to the next level. If a ball hits you or the line you are drawing, you lose a life.

To start Erix

1. Scroll to **Extras**, **YES**, **Games**, **YES**, **Erix**, **YES**.
2. To start the game, press **YES**.

You can select difficulty level or resume the game by pressing

. Instead of selecting **Start**, you can select **Help** or **Highscores** at step 2.

To control Erix

- **5** = up, **0** = down, **7** = left, **9** = right

Tools

Alarm Clock

The phone has an alarm clock that can be set to ring at a specific time within 24 hours. You can also set a recurrent alarm to ring at a specific time on several days. For example, it can ring at 8 am on Monday, Wednesday and Friday. You can have both these alarms set at the same time. Even if you have set your phone to silent the alarm and timer signal rings.

To set an alarm

1. Scroll to **Extras, YES, Time, YES, Alarms, YES, Alarm, YES**.
2. Enter the time.
3. Press **YES** to confirm your setting.

To change the time of an alarm

1. Scroll to **Extras, YES, Time, YES, Alarms, YES, Alarm, YES, New time, YES**.
2. Enter the time and press **YES** to confirm your setting.

To turn the alarm signal off

- Press any key to turn the alarm signal off when it rings. If you do not want the alarm to be repeated, press **YES**.

To cancel an alarm

1. Scroll to **Extras, YES, Time, YES, Alarms, YES, Alarm, YES**.
2. Select **Cancel** and press **YES**.

To set a recurrent alarm

1. Scroll to **Extras, YES, Time, YES, Alarms, YES, Recurrent alarm, YES**.
2. Enter the time and press **YES**.
3. Select the days that you want the alarm to recur by scrolling and pressing **(* ⌀)**. Press **YES** to exit the menu.
You can view the days in the **Recurrence rule** sub-menu.

New time
12:00
(HH:MM)

Recurrence rule
<input checked="" type="checkbox"/> Monday
<input type="checkbox"/> Tuesday
<input type="checkbox"/> Wednesday
<input type="checkbox"/> Thursday

To change the time for a recurrent alarm

1. Scroll to **Extras, YES, Time, YES, Alarms, YES, Recurrent alarm, YES**.
2. Select **New time** and press **YES**.
3. Enter the new time for your recurrent alarm and press **YES**.

To turn the alarm signal off

- Press any key to turn the alarm signal off when it rings. If you do not want the alarm to be repeated, press **YES**.

To cancel a recurrent alarm

1. Scroll to **Extras, YES, Time, YES, Alarms, YES, Recurrent alarm, YES**.
2. Select **Cancel** and press **YES**.

Motion Snooze

If you set the motion snooze to on, you can interrupt the alarm clock with a motion, for example, by moving your hand over the phone.

To turn motion snooze on or off

1. Scroll to **Extras, YES, Time, YES, Alarms, YES, Motion snooze, YES**.
2. Select **On** or **Off** and press **YES**.

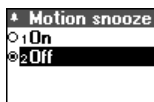

Alarm Signal

To change the alarm signal

1. Scroll to **Settings, YES, Sounds & alerts, YES, Alarm signal, YES**.
2. Select a signal and press **YES**.

Stopwatch

The phone has a built-in stopwatch.

To run the stopwatch

1. Scroll to **Extras, YES, Time, YES, Stopwatch, YES**.
2. Press **YES** to start the stopwatch. Press **YES** again to stop it.

By pressing **#** when the stopwatch is running, you can save up to nine lap times. Press **<** or **>** to check your saved lap times.

To reset the stopwatch

- Press **C** when the stopwatch is not running.

Note: *The stopwatch is turned off when you answer an incoming call or when you exit the stopwatch menu.*



Timer

The phone has a built-in 24-hour timer.

To set the timer

1. Scroll to **Extras, YES, Time, YES, Timer, YES**.
2. Enter the hours, minutes and seconds and press **YES**.
The countdown begins. The timer is shown in standby mode.
When the alert sounds, press any key to turn it off.

To set a new time when the timer is running

1. Scroll to **Extras, YES, Time, YES, Timer, YES, New time, YES**.
2. Enter the time and press **YES**.
The countdown begins. The timer is shown in standby mode.
When the alert sounds, press any key to turn it off.

Calculator

The phone has a built-in calculator, which can add, subtract, divide and multiply.

- Press C to get **+, -, x, /**.
- Press C to delete the figure to the left of the cursor.
- Press C to enter a decimal point.

To use the calculator

In this example, we are going to divide 134 by 32.

1. Scroll to **Extras, YES, Calculator, YES**.
2. Enter **134**.
3. Press C repeatedly until the division sign ($/$) appears.
4. Enter **32**.
5. Press **YES** to get the answer.
6. To clear the display, press C .

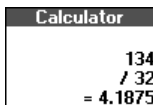
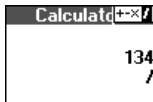
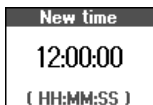

Online Services



Online services are customized services offered by network operators, independently of mobile phones and mobile phone manufacturers.

A SIM card which supports Online services works in the same way as a normal SIM card. When you have inserted your SIM card and turned on your phone, your network operator can download data to your SIM card. After the first data download and after restarting your phone, a new menu appears in your phone as the first sub-menu under the **Extras** menu.

To enter your new menu system

- Scroll to **Extras, YES, Online services, YES**.

Note: *This menu only appears if your SIM card supports this service. Some operators may not use the name "Online services". Your phone may not support all of the services offered.*

Your network operator can, at any time, download new data, for example a new feature, to your SIM card. You may be notified by a message in your display.

Ericsson Mobile Internet

When you are on the move and in need of communication and information, the **Ericsson Mobile Internet** is the answer.

The Ericsson Mobile Internet is a service supplied by Ericsson to make it easier for you to communicate and receive information quickly, wherever you are. It gives you access to various messaging services, on-line customer services, user manuals and other useful information. Some WAP profiles can be set up from your PC at the Ericsson Mobile Internet. You can also download communications software to ensure you get the best out of your Ericsson products.

You can access the Ericsson Mobile Internet via the WAP browser in your phone and via the Internet browser on your computer.

The **Ericsson Mobile Internet** address is:

<http://mobileinternet.ericsson.com>

Troubleshooting

Here are some problems that you might have while using your phone. Some problems require that you call your service provider, but most of the problems you encounter you can easily correct yourself.

Error Messages

Insert Card

There is no SIM card in the phone or you may have inserted it incorrectly. Insert a SIM card. See “SIM Card” on page 7.

Insert Correct SIM Card

The phone may have been locked by the network operator to work only with a certain SIM card. Insert the correct SIM card.

SOS Calls Only

You are within range of a network but you are not allowed to use it. However, in an emergency, some operators allow you to make an emergency call. See “Making Emergency Calls” on page 13.

No Network

There is no network within range or the received signal is too weak. You have to move to get a signal that is strong enough.

Wrong PIN, Wrong PIN2

You have entered your PIN or PIN2 incorrectly. Enter the correct PIN or PIN2, and press **YES**. See “Locking the SIM Card” on page 96.

Codes Do not Match

When you want to change a security code (for example your PIN) you have to confirm the new code by entering it again. The two codes that you have entered do not match. See “Locking the SIM Card” on page 96.

PIN/PIN2 Blocked

You have entered your PIN or PIN2 incorrectly three times in a row. To unblock, see “Locking the SIM Card” on page 96.

PUK Blocked - Contact Operator

You have entered your personal unblocking key code (PUK) incorrectly 10 times in a row. Contact your network operator.

Phone Locked

The phone is locked. To unlock the phone, see “Locking the Phone” on page 97.

Phone Lock Code:

Your phone comes with the phone lock code, **0000**. You can change it to any four- to eight-digit code. See “Locking the Phone” on page 97.

Number not Permitted

The **Fixed Dialling** function is on and the number you have dialled is not on your fixed numbers list. See “Fixed Dialling” on page 99.

Charging, Alien Battery

The battery you are using is not an Ericsson-approved battery and is charging slowly for safety reasons.

Other Problems

No Indication of Charging

When you start charging a battery that is empty or a battery that has not been used for a long time, it may take a while before the indicator on the top of the phone shows a red light and the battery meter appears.

Cannot Access a Certain Function

The function or service may be dependent on your SIM card or the network. Contact your network operator.

Cannot Receive Any Calls

- You may have diverted your incoming calls to another phone number. To cancel the **Divert calls** service, see “Cancelling Divert Calls” on page 86.
- You may have set the **Accept Calls** option to **From no one** or **From list**. Select **From all**. See “To set the accept options” on page 100.
- You may have selected **Data** as the next incoming call. Select **Voice**. See “To receive a voice or data call” on page 72.
- You may have selected **GPRS only** for a data account. Select **Automatic** instead. See “To create a data account” on page 62. If you still cannot receive incoming calls, it could be due to network limitations.

Cannot Speed Dial

Your contacts are not saved on the SIM card. To copy the contacts to the SIM card, see “To copy contacts to the SIM card” on page 37.



Cannot Access My Contacts

Your contacts are not saved in the phone. To copy the contacts to the phone, see “To copy contacts to the phone” on page 37.

Technical Data

General

Product name	R520
System	GSM 900/GSM1800/GSM1900
SIM card	Small plug-in card, 3V or 5V type
Type number	1130101-BV
Talktime (with an ultra slim battery)	Up to 10 hours
Standby time (with an ultra slim battery)	Up to 300 hours (>12 days)

Dimensions

Size	130 x 50 x 16 mm
Weight (+ultra slim battery)	105 g

Ambient temperatures

Max	+55°C
Min	-10°C

GSM data

Data transmission rate	Up to 28.8 kb/s on networks supporting HSCSD (High Speed Circuit Switched Data). With V.42bis compression, you can reach data transmission rates up to four times higher, depending on the data type and the network.
------------------------	--

GPRS (General Packet Radio Services)

Data transmission rate	Up to 53.6 kb/s.
------------------------	------------------

Infrared communication

Coverage area	Up to 1 metre (3.3 ft)
Standards for transfer	RS20 supports full implementation of standard IrDA and IrDA-Ultra.
Data transmission rate	Up to 115.2 kb/s.

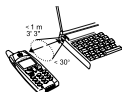

CLASS 1 LED PRODUCT.

The IrDA Feature Trademark is owned by the Infrared Data Association and is used under licence therefrom.

Cable

Cable type	RS232 (V.24)
Data transmission rate	Up to 230.4 kb/s.

Bluetooth wireless technology

Coverage area	Up to 10 metres (33 ft.)
Transmission power	1mW (0dBm)
Frequency band	2.4 GHz - the unlicensed ISM band
Power consumption	Standby current: < 0.3 mA Voice mode: 8-30 mA Data mode average: 5 mA [0.3-30 mA, 20 kb/s, 25%]
Data transmission rate	Up to 108.8 kb/s with one time slot.

Bluetooth Capability Statement

This product is manufactured to comply with the *Bluetooth* specification 1.1. However, since the qualification for the 1.1 specification is not yet available, this product has been formally qualified according to the *Bluetooth* specification 1.0b.

The following *Bluetooth* functions are supported:

- Generic Access Profile
- Serial Port Profile
- Headset Profile
- Dial-up Networking Profile
- Generic Object Exchange Profile
- Object Push Profile
- Synchronization Profile

Safe and Efficient Use

Note: *Please read this information before using your mobile phone.*

Your mobile phone is a highly sophisticated electronic device. To get the most out of your mobile phone, please read this section about product care, and safe and efficient use.

Product Care

- **Do not** expose your product to liquid or moisture.
- **Do not** expose your product to extreme high or low temperatures.
- **Do not** expose your product to lit candles, cigarettes, or cigars, or to open flames etc.
- **Do not** drop, throw or try to bend the product as rough treatment could damage your product.
- **Do not** paint your product as the paint could obstruct the earpiece, microphone or any moveable parts and prevent normal use.
- **Do not** attempt to disassemble your product. The product does not contain consumer serviceable components. Only Ericsson Service Points or Certified Service Centres should perform service.
- **Do not** use any accessories other than Ericsson originals, with the exception of products approved by the Bluetooth Qualification Review Board. Use of non-Ericsson original accessories may result in loss of performance, damage to the product, fire, electric shock or injury. The warranty does not cover product failures which have been caused by use of non-Ericsson original accessories.
- **Treat your product with care, keep it in a clean and dust-free environment.**

Antenna Care

- To avoid impaired performance, please ensure your mobile phone's antenna is not bent or damaged.
- Do not remove the antenna yourself. If your mobile phone's antenna is damaged, please take it to an Ericsson Service Point or Certified Service Centre.

- Use only an antenna that has been specifically designed for your mobile phone. Use of unauthorized antennas, modifications, or attachments could damage the mobile phone and may violate the appropriate regulations, causing loss of performance and radio frequency (RF) energy above the recommended limits.

Efficient Use

For optimum performance with minimum power consumption please:

- Hold the mobile phone as you would any other telephone. While speaking directly into the mouthpiece, angle the antenna in a direction up and over your shoulder. If the antenna is extendable/retractable, it should be extended during a call.
- Do not hold the antenna when the mobile phone is in use. Holding the antenna affects call quality, may cause the mobile phone to operate at a higher power level than needed and may shorten talk and standby times. If your mobile phone is equipped with an infrared port, never direct the infrared ray at anyone's eye and make sure that it does not disturb any other infrared units.

Radio Frequency Energy

Your mobile phone is a low-power radio transmitter and receiver. When it is turned on, it intermittently receives and transmits radio frequency (RF) energy (radio waves). The system that handles the call controls the power level at which the phone transmits.

Exposure to Radio Frequency Energy

All Ericsson mobile phone models are designed to not exceed the limits for exposure to RF energy set by national authorities and international health agencies.* These limits are part of comprehensive guidelines and establish permitted levels of radio wave exposure for the general population. The guidelines were developed by independent scientific organizations such as ICNIRP (International Commission on Non-Ionizing Radiation Protection) through periodic and thorough evaluation of scientific studies. The limits include a substantial safety margin designed to assure the safety of all persons, regardless of age and health, and to account for any variations in measurements.

*Examples of radio frequency exposure guidelines and standards that Ericsson mobile phone models are designed to conform to:

- ICNIRP, "Guidelines for limiting exposure to time-varying electric, magnetic, and electromagnetic fields (up to 300 GHz)", International Commission on Non-Ionizing Radiation Protection

(ICNIRP), Health Physics, vol.74, pp.494-522, April 1998.

- 99/519/EC, EU Council Recommendation on the limitation of exposure to the general public to electromagnetic fields 0 Hz-300 GHz, Official Journal of the European Communities, July 12, 1999.
- ANSI/IEEE C95.1-1992. "Safety levels with respect to human exposure to radio frequency electromagnetic fields, 3kHz to 300 GHz", The Institute of Electrical and Electronics Engineers Inc., New York, 1991.
- FCC Report and Order, ET Docket 93-62, FCC 96-326, Federal Communications Commission (FCC), August 1996.
- Radiocommunications (Electromagnetic Radiation Human Exposure) Standard 1999, Australian Communications Authority (ACA), May 1999.

Driving

Check the laws and regulations on the use of mobile phones in the areas where you drive. If you are going to use your mobile phone while driving, please:

- Give full attention to driving.
- Use an Ericsson Vehicle Handsfree Solution, if available. Law in many countries/states requires drivers to use a Vehicle Handsfree Solution. Read the installation instructions carefully before installing a Vehicle Handsfree Solution.
- Pull off the road and park before making or answering a call if driving conditions so require.

RF energy may affect some electronic systems in motor vehicles such as car stereo, safety equipment etc. In addition, some vehicle manufacturers do not allow use of mobile phones in their vehicles, unless the installation is supported by a handsfree kit with an external antenna. Check with your vehicle manufacturer's representative to be sure that your mobile phone will not affect the electronic systems in your vehicle.

Vehicles Equipped with an Air Bag

An air bag inflates with great force. Do not place objects, including either installed or portable wireless equipment, in the area over the air bag or in the air bag deployment area. If in-vehicle wireless equipment is improperly installed and the air bag inflates, serious injury could result.

Electronic Devices

Most modern electronic equipment, for example equipment in hospitals and cars, is shielded from RF energy. However, certain electronic equipment is not, therefore:

- Do not use your mobile phone near medical equipment without requesting permission.

Mobile phones may affect the operation of some implanted cardiac pacemakers and other medically implanted equipment. Pacemaker patients should be aware that the use of a mobile phone very close to a pacemaker might cause the device to malfunction. Avoid placing the mobile phone over the pacemaker, e.g. in your breast pocket.

When using the mobile phone, place it at the ear opposite the pacemaker. If a minimum distance of 15 cm is kept between the mobile phone and the pacemaker, the risk of interference is limited. If you have any reason to suspect that interference is taking place, immediately turn off your mobile phone.

Contact your cardiologist for more information.

Some hearing aids might be disturbed by mobile phones. In the event of such disturbance, you may want to contact your local Call Centre to discuss alternatives.

Aircraft

- Turn off your mobile phone before boarding any aircraft. To prevent interference with communication systems, you must not use your mobile phone while the plane is in the air.
- Do not use it on the ground without permission from the crew.

Blasting Areas

Turn off your mobile phone when in a blasting area or in areas posted “turn off two-way radio” to avoid interfering with blasting operations. Construction crews often use remote control RF devices to set off explosives.

Explosive Atmospheres

Turn off your mobile phone when in any area with a potentially explosive atmosphere. It is rare, but your mobile phone or its accessories could generate sparks. Sparks in such areas could cause an explosion or fire resulting in bodily injury or even death.

Areas with a potentially explosive atmosphere are often, but not always, clearly marked. They include fuelling areas, such as petrol stations, below deck on boats, fuel or chemical transfer or storage facilities, and areas where the air contains chemicals or particles, such as grain, dust, or metal powders.

Do not transport or store flammable gas, liquid, or explosives in the same compartment of your vehicle that contains your mobile phone and accessories.

Power Supply

- Connect the AC power adapter only to designated power sources as marked on the product.
- To reduce risk of damage to the electric cord, remove it from the outlet by holding onto the AC adapter rather than the cord.
- Make sure the cord is positioned so that it will not be stepped on, tripped over or otherwise subjected to damage or stress.
- To reduce risk of electric shock, unplug the unit from any power source before attempting to clean it.
- The AC power adapter must not be used outdoors or in damp areas.

Children

DO NOT ALLOW CHILDREN TO PLAY WITH YOUR MOBILE PHONE SINCE IT CONTAINS SMALL PARTS THAT COULD BECOME DETACHED AND CREATE A CHOKING HAZARD.

Disposing of the Product

The product should never be placed in municipal waste. Please check local regulations for disposal of electronic products.

Emergency Calls

IMPORTANT!

This mobile phone, like any mobile phone, operates using radio signals, cellular and landline networks as well as user-programmed functions, which cannot guarantee connection under all conditions. Therefore you should never rely solely upon any mobile phone for essential communications (e.g. medical emergencies).

Remember, in order to make or receive calls, the mobile phone must be switched on and in a service area with adequate cellular signal strength. Emergency calls may not be possible on all cellular phone networks or when certain network services and/or mobile phone features are in use. Check with your local service provider.

Battery Information

Charging the Battery

The battery delivered with your phone is not fully charged. We recommend that you charge the battery for 4 hours before you use the phone for the first time. If you are charging a new battery, or a battery that has run out completely, it may take a while before you get any indication (the top indicator lights up and the battery meter appears in the display) that the battery is being charged.

Please note that you cannot turn on the phone before the indicator lights up and the battery meter appears in the display.

The battery can only be charged in temperatures between +5°C (+41°F) and +45°C (+113°F).

Battery Use and Care

A rechargeable battery has a long service life if treated properly. A new battery or one that has not been used for a long time could have reduced capacity the first few times it is used.

- The talk and standby times depend on the actual transmission conditions when using the phone. If the phone is used near a base station, less power is required and talk and standby times are prolonged.
- Use only Ericsson original batteries and chargers. Using other batteries and chargers could be dangerous, and the warranty does not cover product failures which have been caused by use of non-Ericsson original batteries and chargers.
- Do not expose the battery to extreme temperatures, never above +60°C (+140°F). For maximum battery capacity, use the battery at room temperature. If the battery is used in low temperatures, battery capacity will be reduced.
- Turn off your phone before removing the battery.
- Use the battery for the intended purpose only.
- Do not attempt to take the battery apart.
- Do not let the metal contacts on the battery touch another metal object. This could short-circuit and damage the battery.
- Do not expose the battery to open flames. This could cause the battery to explode.



- Do not expose the battery to liquid.
- Do not allow the battery to be put into the mouth. Battery electrolytes may be toxic if swallowed.

Disposing of the Battery

The battery should never be placed in municipal waste. Please check local regulations for disposal of batteries.

Not for Commercial Use
Ericsson Mobile Communications AB

Limited Warranty

Thank you for purchasing this Ericsson Product. To get maximum use of your new Product we recommend that you follow a few simple steps:

- Read the Guidelines for Safe and Efficient use.
- Read all the terms and conditions of your Ericsson Warranty.
- Save your original receipt. You will need it for warranty repair claims. Should your Ericsson Product need warranty service, please return it to the dealer from whom it was purchased or contact your local Ericsson Call Centre to get further information.

Our Warranty

Ericsson warrants this Product to be free from defects in material and workmanship at the time of its original purchase by a consumer, and for a subsequent period of one (1) year.

Any Ericsson accessory is covered by a warranty period of one (1) year from the date of its original purchase by a consumer in accordance with the applicable terms and conditions stipulated herein.

What We Will Do

If, during the warranty period, this Product fails to operate under normal use and service, due to improper materials or workmanship, Ericsson subsidiaries, authorized distributors, Service Points or Certified Service Centres will, at their option, either repair or replace the Product in accordance with the terms and conditions stipulated herein.

Conditions

1. The warranty is valid only if the original receipt issued to the original purchaser by the dealer, specifying the date of purchase and serial number, is presented with the Product to be repaired or replaced. Ericsson reserves the right to refuse warranty service if this information has been removed or changed after the original purchase of the Product from the dealer.

2. If Ericsson repairs or replaces the Product, the repaired or replaced Product shall be warranted for the remaining time of the original warranty period or for ninety (90) days from the date of repair, whichever is longer. Repair or replacement may involve the use of functionally equivalent reconditioned units. Replaced faulty parts or components will become the property of Ericsson.
3. This warranty does not cover any failure of the Product due to normal wear and tear, or due to misuse, including but not limited to use in other than the normal and customary manner, in accordance with Ericsson's instructions for use and maintenance of the Product. Nor does this warranty cover any failure of the Product due to accident, modification or adjustment, acts of God, improper ventilation or damages resulting from liquid.
4. This warranty does not cover Product failures due to improper repair installations, modifications or service performed by a non-Ericsson Service Point or Certified Service Centre or opening of the Product by non-Ericsson certified persons.
5. The warranty does not cover Product failures which have been caused by use of non-Ericsson original accessories.
6. Tampering with any of the seals on the Product will void the warranty.
7. THERE ARE NO EXPRESS WARRANTIES, WHETHER WRITTEN OR ORAL, OTHER THAN THIS PRINTED LIMITED WARRANTY. ALL IMPLIED WARRANTIES, INCLUDING WITHOUT LIMITATION THE IMPLIED WARRANTIES OR MERCHANTABILITY OR FITNESS FOR A PARTICULAR PURPOSE, ARE LIMITED TO THE DURATION OF THIS LIMITED WARRANTY. IN NO EVENT SHALL ERICSSON BE LIABLE FOR INCIDENTAL OR CONSEQUENTIAL DAMAGES OF ANY NATURE WHATSOEVER, INCLUDING BUT NOT LIMITED TO LOST PROFITS OR COMMERCIAL LOSS, TO THE FULL EXTENT THOSE DAMAGES CAN BE DISCLAIMED BY LAW.

Some countries/states do not allow the exclusion or limitation of incidental or consequential damage, or limitation of the duration of implied warranties, so the preceding limitations or exclusions may not apply to you. This warranty gives you specific rights, and you may also have other legal rights which may vary from country/state to country/state.

International Service

You can have your Ericsson Product serviced within the warranty period in any country/state where an **identical** Product is sold by an authorized Ericsson distributor. To find out if your Product is sold in the country/state you are in, please call the local Call Centre. In order to be granted service, you have to present your original receipt specifying the date of purchase and serial number. Please observe that certain services may not be possible elsewhere than in the country/state of original purchase, for example due to the fact that your Ericsson Product may have an interior or exterior which is different from equivalent models sold in other countries/states. It may not be possible to repair SIM-locked Products.

Regulatory Information

Declaration of Conformity

We, **Ericsson Mobile Communications AB** of
Torshamnsgatan 27
S-164 80 Stockholm, Sweden

declare under our sole responsibility that our product

Ericsson type 1130101-BV

and in combination with our accessories, to which this declaration relates is in conformity with the appropriate standards 3GPP TS 51.010-1, ETS 300 342-1 and EN 60950, following the provisions of, Radio Equipment and Telecommunication Equipment directive **99/5/EC** with requirements covering EMC directive **89/336/EEC**, and Low voltage directive **73/23/EEC**.

Kista February 23, 2001

Place & date of issue



Anders Torstensson, President BU GSM

CE 0682 ⓘ

We fulfil the requirements of the R&TTE Directive (**99/5/EC**).

FCC Statement





















Before a phone model is available for sale to the public, it must be tested and certified to the FCC that it does not exceed the limit established by the government-adopted requirement for safe exposure. The tests are performed in positions and locations (i.e. at the ear and worn on the body) as required by the FCC for each model. Body worn measurements are made while the phone is in use and worn on the body with an Ericsson accessory. The design and composition of an accessory can affect the body worn SAR (Specific

























Absorption Rate) levels for the phone. Ericsson has not measured, and makes no representation about the body worn SAR levels when the phone is used with non-Ericsson accessories.

















This device complies with Part 15 of the FCC rules. Operation is subject to the following two conditions: (1) This device may not cause harmful interference, and (2) This device must accept any interference received, including interference that may cause undesired operation.







Icons

The table below shows icons which may appear in standby or in the menus.

Icon	Description
	Your personal phone book.
	Handling of text and voice messages.
	Handling of call time, call cost information and ongoing calls.
	Personal settings, profiles, divert calls, networks and voice control.
	Bluetooth, calendar, synchronization, voice memo, alarm clock and other extras.
	Gives you access to WAP services on the Internet.
	A selection of your most frequently used functions.
	Help text.
	Tells you the strength of the GSM network signal.
	GPRS is within range.
	GPRS is within range and can be used.
	You cannot receive any incoming calls.
	Tells you the status of the battery.
	You have missed an incoming call.
	All incoming calls are diverted to a defined number. No calls or only certain calls from numbers in a list are received.
	The speakerphone is on.
	The ring signal is turned off.
	All signals are turned off, except the alarm and timer.



















Icon	Description
	The alarm clock has been set and is on.
	You have received a text message.
	You have received a voice message.
	You have received a WAP push message.
	The <i>Bluetooth</i> function is on.
	The <i>Bluetooth</i> function is in discoverable mode.
	<i>Bluetooth</i> communication is in progress.
	The infrared port is on.
	Infrared communication is in progress.
	Line 1 is in use for outgoing calls.
	Line 2 is in use for outgoing calls.
	Ciphering is currently not being provided by the network.
	The keypad is locked.
	The card lock or phone lock is on.
	A secure WAP connection is established.
	An ongoing call.
	A missed call in the call list.
	An answered call in the call list.
	A dialled number in the call list.
	A group of contacts in the phone book.
	A text message has not been read.
	A text message is saved on the SIM card.
	A voice message has not been checked.
	You can enter the phone book by pressing  .

Icon	Description
	A home number in the phone book.
	A work number in the phone book.
	A mobile number in the phone book.
	A fax number in the phone book.
	Another number in the phone book.
	An e-mail address in the phone book.
	A voice command has been recorded for a contact name.
	You have recorded a voice memo.
	A <i>Bluetooth</i> headset, not paired with your phone.
	A <i>Bluetooth</i> headset, paired with your phone.
	A <i>Bluetooth</i> phone, paired with your phone.
	A <i>Bluetooth</i> PC, paired with your phone.
	A <i>Bluetooth</i> printer, paired with your phone.
	A <i>Bluetooth</i> PDA, paired with your phone.
	The appointment is a meeting.
	The appointment is a date.
	The appointment is to travel.
	The appointment is a vacation.
	The appointment is an anniversary.
	A miscellaneous appointment.
	An all day calendar appointment.
	A recurrent calendar appointment.
	A reminder is set for a calendar appointment.
	A task in your calendar.

Icon	Description
	A task of high priority.
	A task of low priority.
	The task is to make a phone call.
	The task is to write a message.
	The network is preferred and can be used.
	The network is forbidden and cannot be used.
	Your network is within range and can be used.

Quick Keys

The table describes some of the most useful key combinations.

To...	Do this when in standby:
make an emergency call	enter the international emergency number 112 and press YES
enter and move through the main menus	press  or 
move up and down in the sub-menus	press  or 
enter the Call list	press YES
voice dial	press and hold YES or say your magic word
call your Voice mail	press and hold 
enter the + sign to make an international phone call	press and hold 
set the phone to silent	press and hold 
reach a contact beginning with a specific letter	press and hold any of the keys  - 
reach a phone number at a specific position.	press the position number and 
speed dial	press any of the number keys  -  and YES
enter Call contact	press and hold 
enter the first sub-menu of the My Shortcuts menu	press and hold 
see which profile you are using	slide the volume key up or down
see today's date	slide the volume key up or down
change the language to Automatic	press  8888 
change the language to English	press  0000 
reject a call	quickly slide the volume key up or down twice when receiving a call

To...

put a call on hold
 retrieve a call
 turn off the microphone

Do this during a call:

press **YES**
 press **YES** again
 press and hold **C**

To...

move through menus or lists
 select a menu or setting
 enter a quick options menu
 delete an item
 go back to standby

Do this when in the menus:

slide (and hold) the volume key up or down
 press **YES**
 press **☒**
 press and hold **C** when in lists
 press and hold **NO**

To...

reach the second letter or character of a key
 reach the third letter or character of a key
 shift between capital and lower-case letters
 enter numbers
 enter a question mark
 enter the @-sign
 enter a space
 delete letters and numbers
 shift between input methods or input languages
 enter a p (pause)
 enter a p (pause)

Do this when entering letters using multitap text input:

slide the volume key up and press any of the number keys
 slide the volume key down and press any of the number keys
 press ***0**, then the letter
 press and hold any of the number keys
 slide the volume key down and press **1**
 slide the volume key down and press **0**
 press **1**
 press **C**
 press and hold ***0**
 press and hold ***0** when saving codes
 press ***0** when composing melodies

To...**Do this when entering letters using T9 Text Input:**

view alternative words	press 0
accept a word and add a space	press 1
enter a full stop	press #
view alternative punctuation marks	press # , then 0 repeatedly
shift between capital and lower-case letters	press *0 , then the letter
enter numbers	press and hold any of the number keys
delete letters and numbers	press C
shift between input methods or input languages	press and hold *0

A quick way to move through the menus is to use **shortcuts**. You simply enter the number of the menu or sub-menu to which you want to go. See “Using Shortcuts” on page 19 and “Instructions” on page 19.

You can quickly and easily reach the settings you use most by placing them in the menu **My Shortcuts**. See “My Shortcuts” on page 21.

For more information about **key functions**, see “Key Functions” on page 17, “Moving through the Menu” on page 19 and “Entering Letters” on page 30.

*Not for Commercial Use
Ericsson Mobile Communications AB*

Index

A

- Accept calls service *100*
- Alarm clock *109*
- Answered calls indicator *12*
- Answering calls *14, 16, 77*
- Answering service. See Voice mail
- Area information *48*
- Ask to save *34*
- Assembling the phone *7*
- Auto lock *97*

B

- Banking by phone See Telephone banking
- Barring calls. See Restricting calls
- Battery *7*
 - attaching *7*
 - charging *8*
 - detaching *8*
 - no indication of charging *115*
- Bluetooth *49*
 - pairing *50*
 - receiving *53*
 - sending *52*
- Business cards *38*

C

- Calculator *111*
- Calendar *56*
 - new appointments *56*
 - new tasks *57*
- Call barring. See Restricting calls
- Call cost *91*
 - setting a credit limit *92*
 - specifying price per call unit *91*
- Call divert. See Diverting incoming calls
- Call forwarding. See Diverting incoming calls

- Call list
 - calling from call list *12*
- Call restrictions. See Restricting calls
- Call time *91*
- Call Waiting service *87*
- Caller ID. See Calling Line Identification *14*
- Calling cards
 - choosing card *106*
 - making a call *106*
 - saving card number *105*
 - saving number *105*
- Calling Line Identification (CLI) *12, 14*
- Calls
 - answering *14, 16, 77*
 - making *11, 77*
 - putting a call on hold *87, 88*
 - putting on hold *15*
 - receiving *14*
 - rejecting *14, 78*
 - switching between calls *88*
- CB. See Area information
- Cell broadcast (CB). See Area information
- Charging *8*
- CLI *14*
- CLI Restriction (CLIR) *13*
- Closed user groups *99*
- Code Memo
 - password *102*
 - reset *102*
 - using *101*

Conference calls 89
 adding new participants 89
 creating 89
 extracting a participant 90
 putting conference on hold 89, 90
 releasing a participant 90
 reviewing participants 89
Contacts 34

D

Data account 62
Date
 format 29
 setting 29
Declaration of Conformity 129
Dialled numbers indicator 12
Display
 greeting text 27
 light 26
Display icons 131
Diverting incoming calls 85
DTMF tones. See Touch tones

E

Elapsed time of calls. See Call time
Emergency calls 13
Erasing and renaming voice memos 82
Error messages 114

F

Fixed numbers dialling 99
Forwarding incoming calls. See diverting incoming calls
Full lock 97

G

Games 107
GPRS 62, 63, 64
Greeting text in the display 27

H

Hiding your number 14

I

Icons in display 131
Indicators in display
 answered calls 12
 dialled numbers 12
 missed calls 12
International calls 13
International emergency number 13
IR link
 activating 54
 connecting IR devices 55

K

Key sound 26

L

Letters 30
Long message 44

M

Magic word 79
Making calls 11, 77
Menus 19
Microphone
 muting 15
Minute minder 92
Missed calls 14
Missed calls indicator 12
Multitap Text Input 30
Muting microphone 15

N

Network
 preferred networks 93
 search 11
 search modes 94
 selecting 93
Note Pad 16

O

Online services 112
Option key 17

P

- Pause *41, 136*
- Phone book *34*
 - business cards *38*
 - checking status of memory *41*
 - contacts *34*
 - creating *34*
 - shortcuts to contacts *35*
- Phone lock
 - activating/cancelling *97*
 - auto lock *97*
 - changing security code *97*
 - full lock *97*
- Phone number
 - displaying own *27*
- Phone number in SMS
 - replying to *47*
- PIN
 - changing *96*
 - entering *11*
- PIN2
 - changing *96*
- Plus sign (+) *13*
- Preparing the phone *6*
- Profiles *73*
 - changing settings *74*
 - selecting *73*
 - using accessories *74*
- PUK *96*

Q

- Quick keys *135*

R

- Receiving calls *14*
- Recording a voice memo *81*
- Rejecting calls *14, 78*
- Resetting phone *29*
- Restricting calls *98*
- Ring signal *23*
 - choosing *24*

S

- Saving numbers *34*
- Scroll *17*
- Scrolling *19*
- Service centre (SMS) *42*

Short Message Service.

Shortcuts

to contacts in phone book *35*

Showing your number *14*

SIM card *7, 112*

inserting *7*

unblocking *96*

SIM card lock *96*

activating, cancelling *97*

SMS *42*

deleting messages *46*

editing messages *44*

forwarding messages *47*

message types *43*

reply requested *43*

service centre *42*

templates *45*

SOS Calls only *114*

SOS calls. See Emergency calls

Speakerphone *15*

Speed dialling *35*

Standby *11*

Stopwatch *110*

Switching the phone on/off. See

Turning the phone on/off

T

T9 Text Input *32*

Technical data *117*

Telephone banking *40*

Text messages. See SMS

Timer *111*

Tools *109*

Touch tones *40*

Troubleshooting *114*

Turning the phone off *14*

Turning the phone on *11*

Two Line service *103*

changing phone lines *103*

V

Vibrating alert *26*

Voice control

answering calls *77*

making calls *77*

recording voice labels *76*

rejecting calls *78*

Voice mail 84
 changing signal 84
 entering voice mail number 84
Volume
 changing 15
Volume key 14
Volume keys 17

W

WAP services 67
 browsing 67
 push messages 70
 security 65, 69